

THE OFFICIAL ASE STUDY GUIDE

ASE Transit Bus Tests



National Institute for
**AUTOMOTIVE
SERVICE
EXCELLENCE**

ASE TRANSIT BUS TESTS

Table of Contents

Overview	3–7
Transit Bus Tests	8–52
• Compressed Natural Gas Engines (H1)	8
• Diesel Engines (H2)	15
• Drive Train (H3).....	22
• Brakes (H4).....	26
• Suspension and Steering (H5).....	30
• Electrical/Electronic Systems (H6).....	35
• Heating, Ventilation and Air Conditioning (H7).....	41
• Preventive Maintenance and Inspection (H8).....	46
Test Prep & Training	54

OVERVIEW

Introduction

The *Official ASE Study Guide for the Transit Bus Tests* is designed to help technicians study for the ASE certification tests. It includes detailed information about the technical knowledge covered in the Transit Bus series. And if needed, you should find it easier to select additional reference material that will help you prepare for your test(s).

ASE voluntary certification helps technicians prove their abilities to themselves, to their employers, and to their customers. By passing ASE tests, you will earn the most valuable credential available to working technicians. Because the tests are tough, you'll have the satisfaction of proving to yourself that you are among the elite in your profession. What's more, these credentials are recognized throughout the U.S.

Certified technicians promote customer trust and improve the image of the industry. And trust and professionalism are the first steps to a better, more prosperous business.

ASE encourages you to take the tests and to join the "proven pros" who wear the ASE Blue Seal of Excellence®.

How Do I Become Certified?

There are eight tests in the Transit Bus certification series. If you pass at least one test, and have at least two years of hands-on working experience in transit bus repair, then you will become certified as an ASE Transit Bus Technician. (Appropriate vocational training may be substituted for up to one year of work experience.)

If you pass H1 or H2, plus H3 through H8, and also meet the work experience requirement, you will earn the certificate of Master Transit Bus Technician. If you are currently certified in Diesel Engines (A9, H2, S2, or T2) and Electrical/Electronic Systems (A6, H6, S6, or T6), you are eligible to take the L2 Electronic Diesel Engine Diagnosis Specialist test.

You will receive your test results at the end of your test appointment. You can review and print them later by logging in to your MyASE account. Results will not be given over the phone nor will they be released to anyone without your written permission. If you fail a test, you must wait 30 days from the test date before you can purchase it again.

OVERVIEW (CONTINUED)

Certification credentials are valid for five years. This ensures that certified technicians are recognized as being up-to-date in their profession. If it has been almost five years since you passed a test, it is time to register for the corresponding recertification test. Most recertification tests are about half the length of the regular tests.

Transit Bus Tests

This *Study Guide* contains Test Specifications, task lists, and sample questions for the following ASE tests:

- Compressed Natural Gas Engines (Test H1)
- Diesel Engines (Test H2)
- Drive Train (Test H3)
- Brakes (Test H4)
- Suspension and Steering (Test H5)
- Electrical/Electronic Systems (Test H6)
- Heating, Ventilation, & A/C (Test H7)
- Preventive Maintenance & Inspection (Test H8)

ASE offers certification in areas including Automobile/Light Truck, Medium/Heavy Truck, Truck Equipment, School Bus, Collision Repair/Refinish, Parts Specialist and Advanced Level specialties. Separate *Study Guides* are available.

For full information on ASE testing as well as downloadable *Study Guides* and other test preparation resources, visit www.ase.com.

Who Writes the Questions?

The questions, written by service industry experts familiar with all aspects of transit bus repair, are entirely job-related. They are designed to test knowledge of the skills that you need to service transit buses; theoretical knowledge is not covered.

Each question has its roots in an ASE “item-writing” workshop where service representatives from working bus technicians, technical educators, transit agency directors, and representatives from parts and equipment manufacturers meet to share ideas and translate them into test questions. Each test question must survive review by all members of the group. The questions are written to deal with practical problems of diagnosis and repair experienced by technicians in their day-to-day work.

Next, all questions are pre-tested and quality-checked on a national sample of technicians. Those questions that meet ASE standards of quality and accuracy are included in the scored sections of the tests; the “rejects” are sent back to the drawing board or discarded altogether.

OVERVIEW (CONTINUED)

How Long are the Tests?

Transit Bus Tests 2017		Certification Tests		Recertification Tests	
Test	Name	Number of questions*	Testing time	Number of questions	Testing time
H1	Compressed Natural Gas Engines	60*	1¼ hrs.	25	30 min.
H2	Diesel Engines	60*	1¼ hrs.	25	30 min.
H3	Drive Train	50*	1 hr.	20	30 min.
H4	Brakes	60*	1¼ hrs.	25	30 min.
H5	Suspension and Steering	55*	1¼ hrs.	23	30 min.
H6	Electrical / Electronic Systems	60*	1½ hrs.	25	45 min.
H7	Heating, Ventilation, & A/C	50*	1¼ hr.	20	45 min.
H8	Preventive Maintenance & Inspection	60*	1¼ hrs.	25	30 min.

* ASE certification tests include 10 research questions that are not counted for score. You will not be told which questions these are, so you should answer every question. No research questions are added to recertification tests. You are eligible to take the recertification test only after you have previously passed the corresponding certification test.

How Do I Prepare for the ASE Tests?

Become familiar with test content and question format.

The Test Specifications in this booklet contain a description of the content covered by each test. The Task Lists describe the actual work performed by technicians in each specialty area. Together, these form a “blueprint” for writing and assembling the ASE tests. Please note that each question on the test is related to a particular task or set of tasks in the task list. Therefore, review the task list, thinking about whether you know how to perform each task listed.

All questions are multiple-choice. The sample questions in this *Study Guide* are examples of the five types of questions on the test. Note that some types of questions have extra instructions that you should follow.

Be sure to read each question carefully so that you understand exactly what is being asked. *Each question tests a specific diagnostic or repair problem and has only one correct answer.*

OVERVIEW (CONTINUED)

To summarize, we suggest the following steps be taken:

Step 1. Carefully read the content list for each test you will attempt.

Step 2. Study the task list for each area.

Step 3. Go over the sample questions to become familiar with each question type. This is very important!

Step 4. Review steps 1 through 3 and identify the skill areas where you need additional study.

Getting Started

Registration information is available on the ASE website at www.ase.com. This site will provide you with the dates and locations that testing is available and other important information, including an electronic version of this and all other ASE *Study Guides*.

While on the ASE website, take the time to create your own **myASE account** (if you do not already have one), which will allow you to register for tests, make your own test appointments, and have direct access to all your personal ASE certification information. And as always, if you have questions that **www.ase.com** does not answer, contact our helpful customer service staff at asehelp@ase.com or 1-800-390-6789.

At the Test Center—Some Tips

Try to be well rested on exam day. Arrive early enough to park and find the Test Center office. Late arrivals may be turned away by Test Center staff. If you cannot take a test because you are late, you will forfeit your test fees.

Bring your admission ticket and government issued photo ID with you. Books, calculators, and other reference materials will not be permitted in the test room. You will be assigned a locker to store all personal items. No electronic devices (including cell phones) are allowed in the test room. Most test centers have airport-level security procedures for all candidates, so be prepared for “wandering” or other security checks.

You will receive scratch paper and pencils, and if you are taking an Advanced Level L1 or L2 test, a Composite Vehicle Reference booklet. After you are seated, the supervisor will explain how to use the computer and mouse. Each test appointment begins with a short tutorial on the operation of the

Bring--

- ✓ Admission Ticket
- ✓ Current Gov't. Issued Photo ID

Leave in locker--

- ✓ Books
- ✓ Calculator
- ✓ Coat
- ✓ Cell Phone
- ✓ Wallet
- ✓ Keys

OVERVIEW (CONTINUED)

computer-based test. You can also preview the system online at www.ase.com/cbt before you arrive at the Test Center.

Each test has a specific time limit, as listed in the chart on page 5. During your test, the computer screen will continuously display the amount of time left. If you finish early, you may either review your answers or end the test and continue to the next test (if your appointment includes multiple tests). Once you submit a test for scoring, you cannot go back and review it. If you are taking several tests and need a break, the best time to take it is at the title screen of one of the tests, **before** you click “Begin.” You can take a break after this if necessary, but the test clock will continue to run.

If a question is difficult, mark the answer that you think is correct and flag the question using the on-screen button. Then go on to the next question. When you have finished the test, you may have time to go back to the flagged questions. Your score is based on the number of correct answers that you give, so you should try to answer every question.

When you finish your last test, there will be a short customer satisfaction survey. After you complete the survey, inform the staff and receive your score reports.

Test Content and Sample Questions

The material that follows is designed to help technicians prepare for the ASE certification tests.

Each section begins with the Test Specifications, which will list the main categories covered on that particular test and the number of test questions, as well as the percentage of the test devoted to each topic.

The Task List describes the work activities a technician should be able to perform. This list was developed by working technicians and technical experts from across the country and is a valuable checklist telling you what to study for the test.

Note that the number of tasks in the list does not equal the number of questions on the test. Some tasks are complex and broad in scope and may be covered by several questions. Other tasks are simple and narrow in scope and one question may cover several tasks. The main goal in listing the tasks is to describe accurately what is done on the job, not to match each task to a particular question. In other words, every question will relate to at least one task, but not every task will be covered on the test.

Sample questions follow the Task List. Although these questions will not appear on tests, they are in the same format as actual test questions. Different types of multiple-choice questions are used on the ASE tests. Note the different instructions for some questions. ■

TEST SPECIFICATIONS AND TASK LIST COMPRESSED NATURAL GAS (CNG) ENGINES (TEST H1)

Content Area	Questions in Test	Percentage of Test
A. General Engine Diagnosis	9	18%
B. Cylinder Head and Valve Train Diagnosis and Repair	4	8%
C. Engine Block Diagnosis, Repair, and Overhaul	4	8%
D. Lubrication and Cooling Systems Diagnosis and Repair	4	8%
E. Air Induction and Exhaust Systems Diagnosis and Repair	7	14%
F. Fuel System Diagnosis and Repair	14	28%
1. High Pressure Systems (6)		
2. Low Pressure Systems (3)		
3. Fuel Controls (5)		
G. Starting and Charging System Diagnosis and Repair	4	8%
H. Ignition System Inspection Diagnosis and Repair	4	8%
Total	50	100%

A. General Engine Diagnosis (9 questions)

1. Verify the complaint, check for and retrieve fault codes, and road test vehicle; review operator service request and past maintenance documents (if available); determine further diagnosis.
2. Inspect engine assembly and engine compartment for natural gas, oil, coolant, exhaust, or other leaks; determine needed repairs.
3. Inspect engine compartment wiring harness, connectors, seals, and locks; check for proper routing and terminal/connector condition; determine needed repairs.
4. Listen for and diagnose engine noises; determine needed repairs.
5. Check engine exhaust for odor, smoke, or excessive temperatures; determine needed repairs.
6. Perform fuel supply system tests; check fuel for contamination and consumption; determine needed repairs.
7. Perform air intake system restriction and leakage tests; determine needed repairs.
8. Perform intake manifold pressure tests; determine needed repairs.

H1 TASK LIST (CONTINUED)

9. Perform exhaust backpressure and temperature tests; determine needed repairs.
10. Perform crankcase pressure test; determine needed repairs.
11. Diagnose no-cranking, cranks but fails to start, hard starting, and starts but does not continue to run problems; determine needed repairs.
12. Diagnose surging, rough operation, misfiring, low power, slow deceleration, slow acceleration, and shutdown problems; determine needed repairs.
13. Isolate and diagnose engine related vibration problems; check engine mounts; determine needed repairs.
14. Check cooling system for temperature protection level, contamination, coolant type and level, temperature, pressure, supplemental coolant additive (SCA) concentration, filtration, and fan operation; determine needed repairs.
15. Check lubrication system for contamination, oil level, condition, temperature, pressure, filtration, and oil consumption; determine needed repairs.
16. Check, record, and clear electronic diagnostic codes; monitor electronic data; determine needed repairs.
17. Perform visual inspection for physical damage and missing, modified, or tampered components; determine needed repairs.
18. Research applicable vehicle and service information, service precautions, and technical service bulletins; determine needed actions.
19. Inspect accessory belts, drives, tensioners, and pulleys for tension and condition; determine needed repairs.
20. Perform engine compression test; determine needed repairs.

B. Cylinder Head and Valve Train Diagnosis and Repair (4 questions)

1. Remove, inspect, disassemble, and clean cylinder head assembly(s).
2. Inspect threaded holes, studs, and bolts for serviceability; service or replace as needed.
3. Measure cylinder head-to-deck thickness, and check mating surfaces for warpage and surface finish; inspect for cracks and damage; check condition of passages; inspect core and gallery plugs; service as needed.
4. Inspect valves, guides, seats, springs, retainers, rotators, locks and seals; determine serviceability and needed repairs.
5. Inspect, reinstall or replace seals and spark plug adaptors/tubes; inspect spark plug threads; service as required.
6. Inspect, reinstall or replace valve bridges (crossheads) and guides; adjust bridges (crossheads).
7. Clean components; reassemble, check, and install cylinder head assembly.
8. Inspect, measure, reinstall, or replace pushrods, rocker arms, rocker arm shafts, and supports for wear, bending, cracks, looseness, and blocked oil passages; determine needed repairs.
9. Inspect, install, and adjust cam followers.
10. Adjust valve clearances.
11. Inspect, measure, and reinstall or replace camshaft and bearings; measure and adjust endplay and backlash.

H1 TASK LIST (CONTINUED)

C. Engine Block Diagnosis, Repair and Overhaul (4 questions)

1. Remove, inspect, service, and reinstall pans, covers, breathers, gaskets, seals, and wear rings.
2. Disassemble, clean, and inspect engine block for cracks; check mating surfaces for damage or warpage and surface finish; check deck height; check condition of passages, core, and gallery plugs; inspect threaded holes, studs, dowel pins and bolts for serviceability; service, reinstall or replace as needed.
3. Inspect cylinder sleeve counterbore and lower bore; check bore distortion; determine needed service.
4. Inspect and measure cylinder walls or liners for wear and damage; determine needed service.
5. Replace/reinstall cylinder liners and seals; check and adjust liner heights.
6. Inspect in-block camshaft bearings for wear and damage; replace as needed.
7. Inspect, measure, reinstall or replace in-block camshaft; measure and adjust end play; inspect, reinstall or replace, and adjust cam followers (if applicable).
8. Clean and inspect crankshaft and journals for surface cracks and damage; check condition of oil passages; check passage plugs; measure journal diameters; check mounting surfaces; determine needed service.
9. Inspect, reinstall or replace main bearings; check cap fit and bearing clearances; check and correct crankshaft endplay.
10. Inspect, reinstall, and time the drive gear train (check timing sensors, gear wear and backlash of crankshaft, camshaft, balance shaft, auxiliary drive, and idler gears); service shafts, bushings, and bearings.
11. Clean, inspect, measure, reinstall or replace pistons, pins, and retainers.
12. Measure piston-to-cylinder wall clearances.
13. Check ring-to-groove clearances and end gaps; install piston rings.
14. Identify piston, connecting rod bearing, and main bearing wear patterns that indicate connecting rod and crankshaft alignment or bearing bore problems; check bearing bore and bushing condition; determine needed repairs.
15. Assemble pistons and connecting rods and install in block; check piston height; replace rod bearings and check clearances; check condition, position, and clearance of piston cooling jets (nozzles).
16. Inspect and measure crankshaft vibration damper; determine needed repairs.
17. Inspect, install, and align flywheel housing.
18. Inspect flywheel or flexplate (including ring gear) and mounting surfaces for cracks, wear, and runout; determine needed repairs.

D. Lubrication and Cooling Systems Diagnosis and Repair (4 questions)

1. Verify engine oil pressure and temperature; check operation of pressure/temperature sensors/switches, pressure gauge, and sending unit.
2. Inspect, measure, repair or replace oil pump, drives, pipes, and screens.
3. Inspect, repair or replace oil pressure regulator valve(s), by-pass valve(s), and filters.
4. Inspect, clean, test, reinstall or replace oil cooler, by-pass valve, oil thermostat, lines and hoses.
5. Inspect turbocharger lubrication and cooling system; repair or replace components as needed.

H1 TASK LIST (CONTINUED)

6. Change oil and filter; select oil type; verify oil level and condition.
7. Inspect, reinstall or replace drive belts, pulleys and tensioners; adjust drive belts and check alignment.
8. Verify coolant temperature and pressure; check operation of temperature/pressure and level sensors/switches, temperature gauge, and sending unit.
9. Inspect and replace cooling system thermostat(s), by-passes, housing(s), and seals.
10. Flush and refill cooling system; bleed air from system; recover coolant.
11. Inspect, repair or replace coolant conditioner/filter, check valves, lines, shutoff valves, and fittings.
12. Inspect, repair, or replace water pump, housing, hoses, idler pulley and drives.
13. Inspect radiator, pressure cap, and tank(s); determine needed service.
14. Inspect, repair, or replace fan hub, fan, and fan clutch; inspect mechanical, hydraulic, and electronic fan controls, fan thermostat, and fan shroud.
15. Pressure test cooling system and radiator cap; determine needed repairs.

E. Air Induction and Exhaust Systems Diagnosis and Repair (7 questions)

1. Inspect, service or replace air induction piping and clamps, air cleaner, and element; check for air restriction or contamination.
2. Inspect, test, and replace turbocharger, wastegate, actuator, and wastegate controls.
3. Inspect and replace intake manifold and gaskets; test temperature and pressure sensors; check connections.
4. Inspect, test, clean, repair or replace aftercooler or charge-air cooler, clamps, and piping system.
5. Inspect, repair or replace exhaust manifold, gaskets, piping, mufflers, insulation/heat shield and mounting hardware; inspect, replace, or repair exhaust after-treatment devices and controls.
6. Inspect, test, service, and replace O₂ sensor, EGR valve and associated controls and wiring.
7. Inspect and repair exhaust brake system.

F. Fuel System Inspection, Diagnosis and Repair (14 questions)

1. High Pressure System (6 questions)

1. Inspect fuel storage cylinders for physical damage, delamination, leaks; inspect mountings, shields, and hardware; repair or replace as required.
2. Inspect and interpret cylinder labels for cylinder compliance; determine needed action.
3. Inspect storage cylinder valves, solenoids, pressure relief device (PRD), fittings, piping, clamps, check valves, and vent tubing; repair or replace as required.
4. Inspect fuel lines, clamps and fittings, fill receptacles, 1/4 turn valve, and high pressure gauge; repair or replace as required.
5. Inspect high pressure regulator, fuel filter, and coolant lines for leaks, proper mounting or damage; repair or replace as required.
6. Service high pressure regulator, filter, coolant lines, hoses, and high pressure tubing as required.
7. Defuel and vent cylinders; remove and replace cylinders.
8. Refuel system; check for leaks.

H1 TASK LIST (CONTINUED)

2. Low Pressure System (3 questions)

1. Inspect low pressure filters, regulator, coolant lines, switch(es), sensor gauge, and tubing; repair or replace as required.
2. Service low pressure coolant lines, filters, gaskets, seals, and O-rings as required.

3. Fuel Controls (5 questions)

1. Inspect fuel shutoff solenoids, throttle actuator, fuel metering devices, control valves, and fuel mixer; repair or replace as required.
2. Inspect engine control module (ECM/ECU), sensors, wiring harness(es), connector(s) and other modules; repair or replace as required.

G. Starting and Charging System Diagnosis and Repair (4 questions)

1. Perform battery state-of-charge test; determine needed service.
2. Perform battery load and capacitance tests; test battery cables for shorts, opens and high resistance. Determine needed service; repair as required.
3. Charge battery using slow or fast charge method as appropriate.
4. Start vehicle using jumper cables, a booster battery, or an auxiliary power supply.
5. Inspect, clean, repair or replace batteries, battery cables, disconnects, and clamps.
6. Inspect, test, and reinstall or replace starter relays, safety switch(es), and solenoids; test engine prelude system.
7. Perform alternator amperage and voltage output tests; perform relay terminal output voltage test; perform charging circuit voltage drop tests; determine needed repairs. Perform repairs as required.
8. Perform starter current draw and circuit voltage drop tests; determine needed repairs. Perform repairs as required.

H. Ignition Systems Diagnosis and Repair (4 questions)

1. Diagnose ignition-related problems such as no-starting, engine misfire, poor drivability, spark knock, power loss, and poor mileage on vehicles with distributorless ignition systems; determine needed repairs.
2. Check for possible ignition system related diagnostic trouble codes (DTC); verify performance parameters.
3. Inspect, test, repair, or replace ignition primary circuit wiring and components.
4. Inspect and test spark plugs, boots, tubes and seals, and wiring; check and adjust spark plug gap.
5. Inspect, test, or replace ignition system secondary circuit wiring and components.
6. Inspect, test, and replace ignition coil(s).
7. Inspect, test, and replace ignition system pick-up sensor or triggering device.
8. Inspect, test, and replace ignition control module or controller. ■

SAMPLE QUESTIONS

COMPRESSED NATURAL GAS ENGINES (TEST H1)

1. A replacement pressure relief device (PRD) vent tube should be made of:
 - (A) rigid non-conductive material.
 - (B) flexible plastic tubing.
 - * (C) electrically conductive tubing.
 - (D) copper tubing.

2. A transit bus with NGV Type 2 fuel tanks is being inspected. There is one 6" (15.24 cm) long cut measuring 0.008" (0.203 mm) deep in the outer covering of a tank. This tank should be:
 - * (A) considered useable as is.
 - (B) rotated until the cut is on top.
 - (C) repaired by removing and replacing the fiber wrap.
 - (D) removed from service.

3. A CNG engine has a history of repeated head gasket failures. Technician A says that low liner height could be the cause. Technician B says that under-torqued head bolts could be the cause. Who is right?
 - (A) A only
 - (B) B only
 - * (C) Both A and B
 - (D) Neither A nor B

4. Technician A says that the oil pressure can go too high if the oil pressure relief valve is stuck open. Technician B says that the oil pressure can go too high if the engine is overfilled with lubricant. Who is right?
 - (A) A only
 - (B) B only
 - (C) Both A and B
 - * (D) Neither A nor B

H1 TASK LIST (CONTINUED)

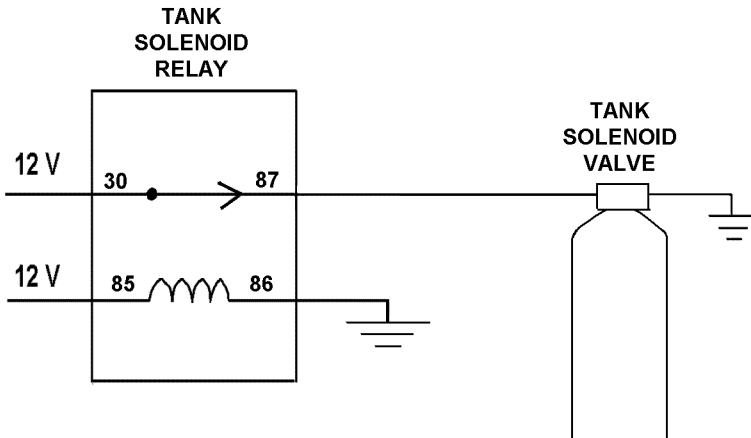

5. The solenoid valve on the tank shown in the illustration is normally closed. Which of the following steps will allow the cylinder to be vented?
- (A) Disconnect the tank solenoid valve wires.
 - (B) Remove the relay and install a jumper wire across terminals 86 and 87.
 - * (C) Remove the relay and install a jumper wire across terminals 30 and 87.
 - (D) Ground the housing of the tank solenoid valve.

This question contains the word EXCEPT. Read the question carefully before choosing your answer.

6. A CNG transit bus with a normal range of 350 miles stops running after 3 hours. The high-pressure fuel gauge shows 375 psi. Any of these could be the cause EXCEPT for a:
- (A) stuck cylinder flow control solenoid.
 - (B) defective engine ECM wiring.
 - (C) low CNG fuel cascade system pressure.
 - * (D) defective high-pressure regulator

TEST SPECIFICATIONS AND TASK LIST

DIESEL ENGINES (TEST H2)

Content Area	Questions in Test	Percentage of Test
A. General Engine Diagnosis	14	28%
B. Cylinder Head and Valve Train Diagnosis and Repair	4	8%
C. Engine Block Diagnosis, Repair, and Overhaul	4	8%
D. Lubrication and Cooling Systems Diagnosis and Repair	7	14%
E. Air Induction and Exhaust Systems Diagnosis and Repair	6	12%
F. Fuel System Diagnosis and Repair	11	22%
1. Mechanical Components (3)		
2. Electronic Components (8)		
G. Starting and Charging System Diagnosis and Repair	4	7%
Total	50	100%

A. General Engine Diagnosis (14 questions)

1. Verify the complaint, and road test vehicle; review operator service request and past maintenance documents (if available); determine further diagnosis.
2. Inspect engine assembly and engine compartment for fuel, oil, coolant, exhaust, or other leaks; determine needed repairs.
3. Inspect engine compartment wiring harness, connectors, seals, and locks; check for proper routing and terminal/connector condition; determine needed repairs.
4. Listen for and diagnose engine noises; determine needed repairs.
5. Check engine exhaust emissions, odor, smoke color, opacity (density) and quantity; determine needed repairs.
6. Perform fuel supply and fuel return system tests; check fuel for contamination, quality/type/grade, and consumption; determine needed repairs.
7. Perform air intake system restriction and leakage tests; determine needed repairs.
8. Perform intake manifold pressure tests; determine needed repairs.
9. Perform exhaust back-pressure and temperature tests; determine needed repairs.
10. Perform crankcase pressure test; determine needed repairs.
11. Diagnose no cranking, cranks but fails to start, hard starting, and starts but does not continue to run problems; determine needed repairs.
12. Diagnose surging, rough operation, misfiring, low power, slow deceleration, slow acceleration, and shutdown problems; determine needed repairs.

H2 TASK LIST (CONTINUED)

13. Isolate and diagnose engine related vibration problems; check engine mounts; determine needed repairs.
14. Check cooling system for temperature protection level, contamination, coolant type and level, temperature, pressure, supplemental coolant additive (SCA) concentration, filtration, and fan operation; determine needed repairs.
15. Check lubrication system for contamination, oil level, quality, temperature, pressure, filtration, and oil consumption; determine needed repairs.
16. Check, record, and clear electronic diagnostic codes; monitor electronic data; determine needed repairs.
17. Perform visual inspection for physical damage and missing, modified, or tampered components; determine needed repairs.
18. Research applicable vehicle and service information, service precautions, and technical service bulletins; determine needed actions.

B. Cylinder Head and Valve Train Diagnosis and Repair (4 questions)

1. Remove, inspect, disassemble, and clean cylinder head assembly(s).
2. Inspect threaded holes, studs, and bolts for serviceability; service or replace as needed.
3. Measure cylinder head-to-deck thickness, and check mating surfaces for warpage and surface finish; inspect for cracks and damage; check condition of passages; inspect core and gallery plugs; service as needed.
4. Inspect valves, guides, seats, springs, retainers, rotators, locks and seals; determine serviceability and needed repairs.
5. Inspect, reinstall or replace injector sleeves and seals; pressure test to verify repair (if applicable); measure injector tip or nozzle protrusion where specified by manufacturer.
6. Inspect, reinstall or replace valve bridges (crossheads) and guides; adjust bridges (crossheads).
7. Clean components; reassemble, check, and install cylinder head assembly as specified by the manufacturer.
8. Inspect, measure, reinstall, or replace pushrods, rocker arms, rocker arm shafts, and supports for wear, bending, cracks, looseness, and blocked oil passages. Visually inspect for wear and correct routing.
9. Inspect, install, and adjust cam followers.
10. Adjust valve clearances and injector settings.
11. Inspect, measure, and reinstall or replace overhead camshaft and bearings; measure and adjust endplay and backlash.

C. Engine Block Diagnosis, Repair and Overhaul (4 questions)

1. Remove, inspect, service, and reinstall pans, covers, breathers, gaskets, seals, and wear rings.
2. Disassemble, clean, and inspect engine block for cracks; check mating surfaces for damage or warpage and surface finish; check deck height; check condition of passages, core, and gallery plugs; inspect threaded holes, studs, dowel pins and bolts for serviceability; service, reinstall or replace as needed.
3. Inspect cylinder sleeve counterbore and lower bore; check bore distortion; determine needed service.

H2 TASK LIST (CONTINUED)

4. Inspect and measure cylinder walls or liners for wear and damage; determine needed service.
5. Replace/reinstall cylinder liners and seals; check and adjust liner heights.
6. Inspect in-block camshaft bearings for wear and damage; replace as needed.
7. Inspect, measure, reinstall or replace in-block camshaft; measure and adjust end play; inspect, reinstall or replace, and adjust cam followers (if applicable).
8. Clean and inspect crankshaft and journals for surface cracks and damage; check condition of oil passages; check passage plugs; measure journal diameters; check mounting surfaces; determine needed service.
9. Inspect, reinstall or replace main bearings; check cap fit and bearing clearances; check and correct crankshaft endplay.
10. Inspect, reinstall, and time the drive gear train (check timing sensors, gear wear and backlash of crankshaft, camshaft, balance shaft, auxiliary drive, and idler gears); service shafts, bushings, and bearings.
11. Clean, inspect, measure, reinstall or replace pistons, pins, and retainers.
12. Measure piston-to-cylinder wall clearances.
13. Check ring-to-groove clearances and end gaps; install piston rings.
14. Identify piston, connecting rod bearing, and main bearing wear patterns that indicate connecting rod and crankshaft alignment or bearing bore problems; check bearing bore and bushing condition; determine needed repairs.
15. Assemble pistons and connecting rods and install in block; check piston height; replace rod bearings and check clearances; check condition, position, and clearance of piston cooling jets (nozzles).
16. Inspect and measure crankshaft vibration damper; determine needed repairs.
17. Inspect, install, and align flywheel housing.
18. Inspect flywheel or flexplate (including ring gear) and mounting surfaces for cracks, wear, and runout; determine needed repairs.

D. Lubrication and Cooling Systems Diagnosis and Repair (7 questions)

1. Verify engine oil pressure and check operation of pressure sensor, pressure gauge, and sending unit.
2. Inspect, measure, repair or replace oil pump, drives, pipes, and screens.
3. Inspect, repair or replace oil pressure regulator valve(s), by-pass valve(s), and filters.
4. Inspect, clean, test, reinstall or replace oil cooler, by-pass valve, oil thermostat, lines and hoses.
5. Inspect turbocharger lubrication system; repair or replace as needed.
6. Change oil and filter, verify oil level and condition.
7. Inspect, reinstall or replace drive belts, pulleys and tensioners; adjust drive belts and check alignment.
8. Verify coolant temperature, and check operation of temperature and level sensors, temperature gauge, and sending unit.
9. Inspect and replace cooling system thermostat(s), by-passes, housing(s), and seals.
10. Flush and refill cooling system; bleed air from system; recover coolant.
11. Inspect, repair or replace coolant conditioner/filter, check valves, lines, shutoff valves, and fittings.
12. Inspect, repair, or replace water pump, housing, hoses, idler pulley and drives.

H2 TASK LIST (CONTINUED)

13. Inspect radiator, pressure cap, and tank(s); determine needed service.
14. Inspect, repair, or replace fan hub, fan, and fan clutch; inspect mechanical, hydraulic, and electronic fan controls, fan thermostat, and fan shroud.
15. Pressure test cooling system and radiator cap; determine needed repairs.

E. Air Induction and Exhaust Systems Diagnosis and Repair (6 questions)

1. Inspect, service or replace air induction piping, air cleaner, and element; check for air restriction or contamination.
2. Inspect, test, and replace turbocharger, wastegate, and wastegate controls.
3. Inspect and replace intake manifold and gaskets; test temperature and pressure sensors; check connections.
4. Inspect, test, clean, repair or replace aftercooler or charge-air cooler and piping system.
5. Inspect, repair or replace exhaust manifold, gaskets, piping, mufflers, insulation/heat shield and mounting hardware; inspect, replace, or repair exhaust after treatment devices
6. Inspect, repair or replace preheater/inlet air heater, starting aids, and controls.
7. Inspect, test, service, and replace EGR system components; including EGR valve, variable ratio/geometry turbocharger, cooler, piping, filter, electronic sensors, controls, system air pressure solenoids, and wiring.
8. Inspect and repair exhaust brake system.

F. Fuel System Diagnosis and Repair (11 questions)

1. Mechanical Components (3 questions)

1. Inspect, repair or replace fuel tanks, vents, cap(s), mounts, valves, screens, crossover system, supply and return lines, and fittings.
2. Inspect, clean, test, repair or replace fuel transfer pump, lift pump, drives, screens, fuel/water separators/indicators, filters, heaters, coolers, ECM cooling plates, and mounting hardware.
3. Check fuel system for air and temperature; determine needed repairs; prime and bleed fuel system; check, repair or replace primer pump.
4. Inspect, test, repair or replace low/high pressure systems (check valves, pressure regulator valves and restrictive fittings).
5. Inspect, adjust, repair or replace mechanical engine throttle and controls.
6. Perform on-engine inspections, tests, adjustments, and time, or replace and time, distributor-type injection pumps.
7. Perform on-engine inspections, tests, and adjustments, or replace mechanical unit injectors.
8. Inspect, test, repair or replace fuel injection nozzles.
9. Inspect, adjust, repair or replace smoke limiters (air/fuel ratio controls).
10. Inspect, reinstall or replace high-pressure injection lines, fittings, seals, and mounting hardware.
11. Inspect, test, adjust, repair or replace engine fuel shut-off devices and controls, including engine protection shut-down devices, circuits and sensors.

H2 TASK LIST (CONTINUED)

2. Electronic Components (8 questions)

1. Check and record engine electronic diagnostic codes and trip/operational data; clear codes; determine needed repairs.
2. Inspect, adjust, repair or replace electronic throttle and PTO (high/low idle) control devices, circuits, and sensors.
3. Perform on-engine inspections, tests, and adjustments on hydraulic electronic unit injectors (HEUI) and electronic controls (rail pressure control).
4. Perform on-engine inspections, tests, and adjustments on electronic unit injectors (EUI) and electronic controls.
5. Inspect, test, adjust, repair or replace engine electronic fuel shut-down components, circuits, and sensors, including engine protection and automatic stop systems.
6. Inspect and test voltage, ignition, and ground circuits and connections for electrical/electronic components; determine needed repairs.
7. Inspect and replace electrical connector terminals, pins, harnesses, seals, and locks.
8. Connect diagnostic tool to vehicle/engine to access allowed service parameters; determine needed repairs.
9. Use a diagnostic tool (hand-held or PC-based, and/or break-out cable or box) to inspect and test electronic engine control system, sensors, actuators, electronic control modules (ECMs), and circuits; determine needed repairs.
10. Measure and interpret voltage, voltage drop, amperage, and resistance readings using a digital multimeter (DMM).

G. Starting and Charging System Diagnosis and Repair (4 questions)

1. Perform battery state-of-charge test; determine needed service.
2. Perform battery load and capacitance tests; determine needed service.
3. Charge battery using slow or fast charge method as appropriate.
4. Start vehicle using jumper cables, a booster battery, or an auxiliary power supply.
5. Inspect, clean, repair or replace batteries, battery cables, disconnects, and clamps.
6. Inspect, test, and reinstall or replace starter relays, safety switch(s), and solenoids.
7. Perform alternator voltage and amperage output tests; determine needed repairs.
8. Perform starter and charging circuit voltage drop tests; determine needed repairs. ■

SAMPLE QUESTIONS

DIESEL ENGINES (TEST H2)

1. An operator complains that a transit bus has excessive black smoke when started in the morning. Which of these could be the cause?
 - * (A) A bad fuel injector nozzle
 - (B) A restricted fuel filter
 - (C) A blocked fuel tank vent
 - (D) A leaking fuel return line
2. An operator complains that a transit bus will not crank. The most likely cause is:
 - (A) loose starter bolts.
 - * (B) a bad starter solenoid.
 - (C) a shorted starter ground cable.
 - (D) the gear selector was left in neutral.
3. When the diesel engine in a transit bus reaches operating temperature, coolant flows out of the surge tank overflow tube.

Technician A says that air in the cooling system could be the cause.

Technician B says that a failed radiator pressure cap could be the cause.

Who is right?

 - (A) A only
 - (B) B only
 - * (C) Both A and B
 - (D) Neither A nor B
4. During a cold weather start-up, the oil filter ruptures, causing an oil leak. This could be caused by:
 - * (A) a stuck-closed oil filter bypass valve.
 - (B) a stuck-open oil pressure regulator valve.
 - (C) use of a high viscosity motor oil.
 - (D) excessive engine rpm at start-up.
5. A transit bus has had repeated serpentine belt failures. Which of these is the most likely cause?
 - (A) A stuck belt tensioner
 - * (B) Misaligned belt pulleys
 - (C) A binding idler bearing
 - (D) An out-of-balance fan

H2 SAMPLE QUESTIONS (CONTINUED)

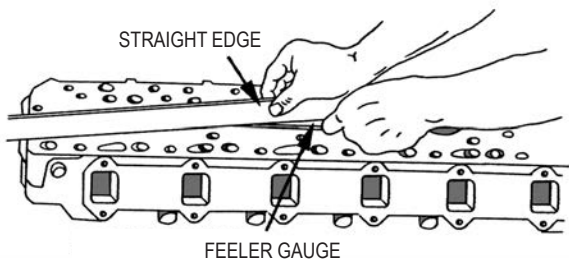

6. What is the technician checking in the illustration shown above?
- (A) Valve protrusion
 - (B) Valve recession
 - (C) Coolant nozzle recession
 - * (D) Cylinder head warpage
7. Which of these can cause a no-start condition on a HEUI engine?
- (A) High fuel pressure
 - * (B) Low injection control pressure
 - (C) High boost pressure
 - (D) Low boost pressure
8. A diesel engine with EUI has a misfire and the check engine light is ON. Fault code "cylinder 4 current below normal" is active. This could be caused by a:
- (A) failed engine position sensor.
 - (B) sticking #4 injector plunger.
 - * (C) broken #4 injector wire terminal.
 - (D) sticking throttle position sensor.

This question contains the word EXCEPT. Read the question carefully before choosing your answer.

9. A transit bus has excessive engine oil consumption and an oil film on the back of the bus. All of these could be the cause EXCEPT:
- (A) bad turbocharger seals.
 - * (B) a cracked cylinder liner.
 - (C) worn piston rings.
 - (D) worn valve guide seals.

TEST SPECIFICATIONS AND TASK LIST

DRIVE TRAIN (TEST H3)

Content Area	Questions in Test	Percentage of Test
A. Automatic Transmission Diagnosis and Repair	28	70%
B. Drive Shaft and Universal Joint Diagnosis and Repair	4	10%
C. Drive Axle Diagnosis and Repair	8	20%
Total	40	100%

A. Automatic Transmission Diagnosis and Repair (28 questions)

1. Diagnose noise, vibration, and shifting problems; determine needed repairs.
2. Check transmission fluid level; check dipstick calibration; diagnose fluid usage, leaks, and condition; determine needed repairs.
3. Perform transmission pressure tests; determine needed repairs.
4. Perform stall tests; determine needed repairs.
5. Perform lock-up converter system tests; determine needed repairs.
6. Diagnose mechanical control systems; determine needed repairs.
7. Replace fluid and internal/external filter(s).
8. Inspect, test, adjust, and/or replace retarder controls, valves, air lines, sensors, and components.
9. Inspect and replace external seals and gaskets.
10. Inspect, test, flush, transmission, transmission cooler and lines; inspect breathers, filters, and fittings; service as required.
11. Inspect, test, reinstall or replace vehicle speed sensor.
12. Inspect and test transmission temperature circuit for accuracy; determine needed repairs.
13. Inspect, test, diagnose, adjust, repair, or replace electrical/electronic components including the transmission control module(TCM), electronic modulators, solenoids, sensors, relays, switches, lights, fuses/breakers, wiring and connectors.
14. Inspect, replace, and align drive train mounts.
15. Remove and replace transmission; inspect flex plate.
16. Inspect engine block, flywheel housing, and transmission mating surfaces; check runout; check engine-to-transmission mounting adapters; determine needed repairs.
17. Inspect, test, repair, or replace electronic shift selectors, switches, displays and indicators, and wiring harnesses.
18. Diagnose automatic transmission and retarder problems using appropriate diagnostic tools and software, procedures, and service information/flow charts; check and record diagnostic trouble codes; clear codes; interpret digital multimeter (DMM) readings; determine needed repairs.

H3 TASK LIST (CONTINUED)

19. Diagnose automatic transmission problems caused by data link/bus interfaces with the transmission control module (TCM); identify electrical interference problems; determine needed repairs.
20. Inspect, adjust, service, repair, or replace power take-off assemblies and controls.

B. Drive Shaft and Universal Joint Diagnosis and Repair (4 questions)

1. Diagnose drive shaft and universal joint noise and vibration problems; determine cause of failure and needed repairs.
2. Inspect, service, or replace driveshaft, slip joints, yokes, drive flanges, universal joints, and vibration dampers; phase drive shaft yokes.
3. Measure drive line angles; determine needed adjustments.

C. Drive Axle Diagnosis and Repair (8 questions)

1. Diagnose rear axle drive unit noise, vibration, and overheating problems; determine needed repairs.
2. Check and repair fluid leaks; inspect and replace rear axle drive unit cover plates, gaskets, breathers, magnetic plugs, and pinion seals.
3. Check rear axle drive unit fluid level and condition; determine needed service; add proper type of lubricant.
4. Remove and replace differential carrier assembly, check ring and pinion backlash, inspect rear axle housing mating surfaces; determine needed repairs.
5. Remove, inspect, and replace axle shafts.
6. Remove and replace rear wheel hub assembly; inspect ABS tone/exciter ring and wheel speed sensor; determine needed repairs.
7. Diagnose wheel bearing noises and damage; determine needed repairs.
8. Clean, inspect, lubricate, and replace wheel bearing cones and races (cups); clean and inspect locking plates and nuts; replace seals, wear rings, and axle flange gasket; adjust rear wheel bearings.
9. Inspect, adjust, repair, or replace planetary axle assemblies including case, idler pinion, pins, gears, thrust washers, shims, seals, cover, and springs. ■

SAMPLE QUESTIONS

DRIVE TRAIN (TEST H3)

1. A transit bus with a diesel engine and an electronic automatic transmission shifts late. Which of these is the most likely cause?
 - (A) An illuminated "Do Not Shift" light
 - (B) A bad retarder accumulator solenoid
 - * (C) A bad throttle position (TP) sensor
 - (D) A bad torque converter clutch (TCC) solenoid
2. An automatic transmission slips when cold, but shifts normally at operating temperature. Which of these could be the cause?
 - (A) A restricted transmission cooler
 - (B) A misadjusted throttle position (TP) sensor
 - * (C) Low fluid level
 - (D) A worn converter hub
3. Which of these could cause the rear axle seals to fail repeatedly?
 - (A) Over-torqued wheel bearings
 - * (B) A restricted axle housing breather
 - (C) A high fluid level
 - (D) Incorrect fluid type
4. A transmission has no lock-up. During a pressure test, no pressure is found at the lock-up test port. This could be caused by:
 - (A) lock-up clutch wear.
 - (B) a locked stator.
 - * (C) a bad lock-up solenoid.
 - (D) a freewheeling stator.
5. A transit bus transmission is to be replaced. Technician A says that the transmission flex plate should be inspected each time the transmission is removed. Technician B says that the flywheel housing should be inspected each time the transmission is removed. Who is right?
 - (A) A only
 - (B) B only
 - * (C) Both A and B
 - (D) Neither A nor B

H3 SAMPLE QUESTIONS (CONTINUED)

6. An operator reports that the transit bus won't go into gear. Technician A says that not engaging the high idle switch could be the cause. Technician B says that not stepping on the brake pedal could be the cause. Who is right?
- (A) A only
 - * (B) B only
 - (C) Both A and B
 - (D) Neither A nor B

7. What operation is being performed in the setup shown in the illustration?
- (A) Adjusting tooth contact
 - * (B) Checking ring gear runout
 - (C) Checking ring gear backlash
 - (D) Setting differential bearing preload

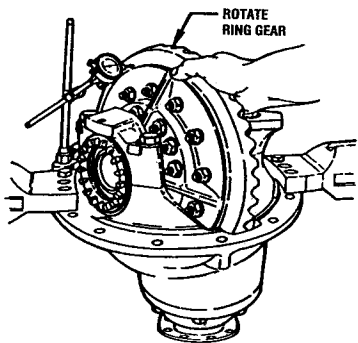

This question contains the word EXCEPT. Read the question carefully before choosing your answer.

8. To most accurately check the fluid level in an automatic transmission, the technician should do all of these EXCEPT:
- (A) park the transit bus on level ground.
 - * (B) check while the fluid is cold.
 - (C) put the transmission in NEUTRAL.
 - (D) turn off the fast idle.

TEST SPECIFICATIONS AND TASK LIST

BRAKES (TEST H4)

Content Area	Questions in Test	Percentage of Test
A. Air Supply and Service Systems Diagnosis and Repair	24	48%
B. Mechanical/Foundation Brakes Diagnosis and Repair	14	28%
C. Parking Brakes Diagnosis and Repair	7	14%
D. Wheel Bearings Diagnosis and Repair	5	10%
Total	50	100%

A. Air Supply and Service Systems Diagnosis and Repair (24 questions)

1. Diagnose poor stopping, pulling, grabbing, dragging, overheating, and air leak (static and applied) problems, caused by supply and service system malfunctions; determine needed repairs.
2. Check air system build up and recovery time; determine needed repairs.
3. Inspect, repair or replace air reservoir tanks.. Check for oil, water, and foreign material. Check mounting brackets and hardware; determine needed repairs.
4. Inspect, adjust, align, or replace air compressor drive gears, and couplings.
5. Inspect, repair, or replace air compressor, air intake, oil and coolant lines and fittings.
6. Inspect, test, adjust, or replace system pressure controls (governor/ relief valve), unloader assembly valves, pressure protection valves, and filters.
7. Inspect, repair, or replace air system lines, hoses, fittings, and couplings.
8. Inspect, test, clean, or replace air tank relief (pop off) valves, one way check valves, drain cocks, automatic drain (spitter) valves, heaters, wiring, and connectors.
9. Inspect, clean, repair, or replace air drier systems, filters, valves, heaters, control modules, wiring, and connectors.
10. Inspect, test, repair, or replace brake application (foot/treadle) valve, fittings, and mounts; check and adjust brake pedal free play.
11. Inspect, test, clean, or replace two way (double) check valves and anti-compounding valves.
12. Inspect, test, repair, or replace stop and parking brake light circuit switches, wiring, and connectors.
13. Inspect, test, repair, or replace brake relay valve and quick-release valves.
14. Inspect, test, repair, or replace interlock system solenoid valves, regulator valves, pressure switches, and related components.
15. Inspect, test, and replace inversion/emergency (spring) brake control valve(s).

H4 TASK LIST (CONTINUED)

16. Inspect, test, repair, or replace low-pressure warning devices.
17. Inspect, test, and replace air pressure sensors, gauges, lines and fittings.
18. Perform antilock brake system and automatic traction control (ABS/ATC) warning lamp start-up test; determine needed repairs; retrieve diagnostic trouble codes (DTCs) using scan tool, PC computer, or LEDs; determine needed repairs.
19. Diagnose poor stopping and lockup problems on antilock brake systems (ABS); determine needed repairs.
20. Test, adjust, or replace antilock brake system (ABS) wheel speed sensors and tone/exciter rings.
21. Test and replace antilock brake system (ABS) and automatic traction control (ATC) system, (ABS/ATC), electronic control units (ECU) and modulator valves, traction control valves; test, repair, and replace wiring and connectors.
22. Verify proper operation of auxiliary (transmission retarder, driveline, exhaust, and engine) braking systems.

B. Mechanical/Foundation Brakes Diagnosis and Repair (14 questions)

1. Diagnose poor stopping, brake noise, overheating, abnormal, premature wear, pulling, grabbing, or dragging complaints caused by foundation brake, slack adjuster, and brake chamber problems; determine needed repairs.
2. Perform deceleration tests on service and parking brake systems.
3. Inspect, test, adjust, repair, or replace service brake chambers, diaphragm, clamp, spring, pushrod, clevis, and mounting brackets.
4. Inspect, test, adjust, or replace automatic slack adjusters.
5. Inspect or replace S-cams, rollers, shafts, bushings, seals, spacers, and retainers; lubricate as necessary.
6. Inspect, or replace brake spider, shields, anchor pins, shoe retainers, bushings, and springs; lubricate as necessary.
7. Inspect, clean, adjust, or replace air disc brake caliper assemblies.
8. Inspect brake shoes, linings, or pads; determine needed repairs.
9. Inspect brake drums or rotors; determine needed repairs.
10. Resurface rotors brake drums and linings.

C. Parking Brakes Diagnosis and Repair (7 questions)

1. Inspect or replace parking (spring) brake chamber; dispose of removed brake chambers in accordance with local regulations.
2. Inspect, test, or replace parking (spring) brake valves, lines, hoses, and fittings.
3. Manually release and cage parking (spring) brakes.
4. Inspect, test, and replace parking brake override valve.
5. Inspect, test, repair, or replace towing circuit components.

D. Wheel Bearings Diagnosis and Repair (5 questions)

1. Remove and replace axle hub and wheel assembly.
2. Clean, inspect, lubricate, or replace wheel bearing assemblies; replace seals and wear rings.
3. Adjust axle wheel bearings in accordance with manufacturers' procedures.
4. Inspect or replace extended service (sealed, close-tolerance, and unitized) bearing assemblies; perform initial installation in accordance with manufacturers' procedures.
5. Replace seals and O-rings on planetary axle assemblies; adjust axle endplay. ■

SAMPLE QUESTIONS BRAKES (TEST H4)

1. A transit bus, with a ruptured air supply tank, is being towed from the front. The technician should:
- (A) prevent the steering wheel from turning.
 - * (B) cage the rear air brake chambers.
 - (C) drain the air from the secondary tank.
 - (D) cage the front air brake chambers.

2. The setup in the illustration shows the first step in:

- (A) measuring chamber pushrod travel.
- (B) adjusting spring brake tension.
- * (C) manually releasing the spring brake.
- (D) adjusting the brakes for lining wear.

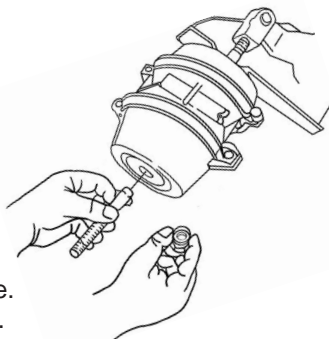

3. Brake shoe-to-drum clearance, on a transit bus with S-cam brakes, is maintained by adjusting the:

- * (A) slack adjuster.
- (B) shoe anchor pins.
- (C) pushrod.
- (D) cam roller eccentrics.

4. The parking brakes fail to apply on a transit bus with air brakes. Technician A says that low air pressure in the spring brake chamber could be the cause. Technician B says that a ruptured spring brake diaphragm could be the cause. Who is right?

- (A) A only
- (B) B only
- (C) Both A and B
- * (D) Neither A nor B

H4 SAMPLE QUESTIONS (CONTINUED)

5. The air line from the air drier to the air supply (wet) tank is being replaced.
Technician A says that there should be no low spots in the line after installation.
Technician B says that a smaller diameter line may be used for the replacement.
Who is right?
- * (A) A only
(B) B only
(C) Both A and B
(D) Neither A or B
6. A transit bus' parking brake valve button pops out immediately after being depressed.
Technician A says that this could be caused by low system air pressure.
Technician B says that this could be caused by air in the emergency chamber.
Who is right?
- * (A) A only
(B) B only
(C) Both A and B
(D) Neither A nor B
7. A transit bus has an uneven braking problem. Which of these could be the cause?
- (A) A binding treadle (foot) valve
(B) Low brake line air pressure
* (C) A bad brake drum
(D) A bad governor

This question contains the word EXCEPT. Read the question carefully before choosing your answer.

8. An air compressor is not unloading, causing the air tank safety valve to pop off. This could be caused by any of these EXCEPT:
- * (A) an obstructed intake.
(B) a restricted governor reservoir line.
(C) a bad governor.
(D) a bad unloader.

TEST SPECIFICATIONS AND TASK LIST SUSPENSION AND STEERING (TEST H5)

Content Area	Questions in Test	Percentage of Test
A. Steering System Diagnosis and Repair	12	27%
B. Suspension Systems Diagnosis and Repair	23	51%
C. Wheel Alignment Diagnosis, Adjustment and Repair	6	13%
D. Wheels and Tires Diagnosis and Repairs	4	9%
Total	45	100%

A. Steering System Diagnosis and Repair (12 questions)

1. Diagnose steering column (tilt, telescoping, or fixed) shaft noise, looseness, and binding problems; determine needed repairs.
2. Inspect and replace steering shaft U-joint(s), slip joint(s), bearings, bushings, and seals; phase steering shaft U-joints.
3. Diagnose hydraulic power steering system noises, steering binding, uneven turning effort, looseness, hard steering, overheating, fluid leakage, and fluid aeration problems; determine needed repairs.
4. Diagnose electrical power steering system noises, steering binding, uneven turning effort, hard steering, unable to return to center, delay; determine needed repairs.
5. Inspect and replace electric steering assembly.
6. Inspect power steering fluid level and condition; determine fluid type and needed service.
7. Purge air from the power steering system.
8. Perform power steering system pressure and flow tests; determine needed repairs.
9. Inspect, service, or replace power steering reservoir including filter, seals, and gaskets.
10. Inspect, adjust, align, or replace power steering pump drive components.
11. Inspect power steering pump drive gear and coupling; replace as required.
12. Inspect, adjust, or repair power steering pump, mountings, and brackets; replace as required.
13. Inspect power steering system cooler, lines, hoses, and fittings; replace as required.
14. Inspect power steering gear; replace as required.
15. Inspect and replace pitman arm; center the steering linkage.
16. Inspect, adjust/service, or replace drag link/center link, idler arm/stabilizer link, tie rods and tie rod ends; position adjusting sleeves, clamps, and retainers.
17. Inspect steering and Ackerman/steering arms; replace as required.

H5 TASK LIST (CONTINUED)

18. Check and adjust steering gear poppet/relief valves, and wheel/steering stops.
19. Diagnose problems in the articulation system electronic controls, and mechanical and hydraulic components; determine needed repairs.

B. Suspension Systems Diagnosis and Repair (23 questions)

► Independent Front Suspensions

1. Diagnose front suspension system noises, looseness, body sway, and ride quality; determine needed repairs.
2. Inspect upper and lower control arms, strut rods/radius arms, bushings, shafts, and rebound/jounce bumpers on short and long arm (SLA) suspension systems; replace as required.
3. Inspect kingpins and bushings/bearings; replace as required.
4. Inspect steering knuckle/spindle assemblies; replace as required.
5. Inspect, test and/or replace air bags; measure and adjust ride height.
6. Inspect stabilizer bar (sway bar) bushings, brackets, and links; replace as required.
7. Inspect shock absorbers, bushings, brackets, and mounts; verify adjustment; replace as required.

► Straight/I-Beam Axle Front Suspensions

8. Diagnose front suspension system noises, looseness, body sway, and ride quality; determine needed repairs.
9. Inspect front axle, U-bolts, and fasteners; service or replace as required.
10. Inspect kingpins, steering knuckles, bushings, locks, bearings, shims, seals, and covers; service or replace as required.
11. Inspect shock absorbers, bushings, brackets, and mounts; verify adjustment; replace as required.
12. Measure vehicle ride height; determine needed adjustments or repairs.
13. Inspect, repair, and/or replace radius rods, lateral/torque rods, stabilizer bar (sway bar), bushings, brackets, mounts, and air bags; adjust as necessary.

► Rear Suspensions

14. Diagnose suspension system noises, looseness, ride quality, and body sway problems; determine needed repairs.
15. Inspect rear axle housing, U-bolts, and fasteners; service or replace as required.
16. Inspect shock absorbers, bushings, brackets, mounts; verify shock absorber adjustments; replace as required.
17. Measure vehicle ride height; determine needed adjustments or repairs.
18. Inspect and adjust rear axle alignment components such as radius rods, air/walking beams, lateral rods, torque rods, stabilizer bars, and related bushings, mounts, shims, and links; replace as required.

► Air Suspension System and Controls

19. Inspect, test, or repair/replace air bags/air springs, mounting plates, suspension arms, and bushings.
20. Inspect, test, adjust, or repair air suspension pressure regulator, pressure protection valve(s), leveling/height control valve(s), linkages, lines, hoses, and fittings; replace as required.
21. Inspect and test operation of kneeling system; perform necessary repairs.

H5 TASK LIST (CONTINUED)

C. Wheel Alignment Diagnosis, Adjustment, and Repair (6 questions)

1. Diagnose vehicle wandering, pulling, shimmy, and steering effort problems; determine needed adjustments or repairs.
2. Check and adjust camber; determine needed repairs.
3. Check and adjust caster; determine needed repairs.
4. Check SAI/KPI (steering axis inclination/kingpin inclination) and included angle; determine needed repairs.
5. Check and adjust toe.
6. Diagnose toe-out-on-turns (Ackerman angle) problems; determine needed repairs.
7. Check rear axle alignment (thrust line/centerline) and tracking; adjust or determine needed repairs.
8. Check and adjust axle wheel bearings.

D. Wheels and Tires Diagnosis and Repair (4 questions)

1. Diagnose tire wear patterns; determine needed repairs.
2. Inspect tires for damage; check and adjust tire pressure.
3. Diagnose wheel/tire vibration and shimmy problems; determine needed repairs.
4. Inspect and replace wheels (rims), studs, and nuts.
5. Measure wheel and tire runout (radial and lateral); determine needed repairs.
6. Balance wheel and tire assembly.
7. Measure tire diameter and/or circumference; match tires and rims. ■

SAMPLE QUESTIONS

SUSPENSION AND STEERING (TEST H5)

1. Technician A says that when replacing a bad front wheel bearing, both bearings and races should be replaced along with the seals. Technician B says that when replacing a bad front wheel bearing, a front alignment should be performed. Who is right?
- * (A) A only (C) Both A and B
(B) B only (D) Neither A nor B
2. A transit bus has hard steering during sharp turns. Which of these could be the cause?
- (A) Incorrect toe
(B) Too much negative caster
* (C) Misadjusted poppet/relief valves
(D) Excessive power steering system pressure
3. A transit bus is leaning to the left in the rear. This could be caused by:
- (A) low pressure from the supply reservoir.
(B) low pressure at the rear accessory/suspension reservoir.
(C) a faulty pressure protection valve.
* (D) a faulty height control/leveling valve.
4. A transit bus operator reports that tight spots in the steering occur while turning the steering wheel. Technician A says that a binding steering column U-joint could be the cause. Technician B says that a worn tie rod end could be the cause. Who is right?
- * (A) A only (C) Both A and B
(B) B only (D) Neither A nor B
5. The operator says that the transit bus lift pan contacts the road surface when going over speed bumps. Which of these could be the cause?
- (A) The system air pressure is too high.
(B) The front of the bus is overloaded.
* (C) The ride height needs to be adjusted.
(D) The shock absorbers are too short.

H5 SAMPLE QUESTIONS (CONTINUED)

6. The operator could not keep the transit bus from wandering while driving at highway speeds.

Technician A says that a 1/8" toe-in setting could be the cause.

Technician B says that a worn tie-rod end could be the cause.

Who is right?

- (A) A only
- * (B) B only
- (C) Both A and B
- (D) Neither A nor B

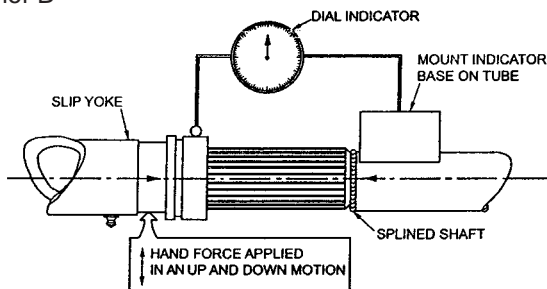

7. Which of these is being measured in the setup shown in the illustration?

- * (A) Steering shaft spline wear
- (B) Steering shaft out-of-roundness
- (C) Steering shaft diameter
- (D) Steering shaft endplay

This question contains the word EXCEPT. Read the question carefully before choosing your answer.

8. A transit bus has 120 psi air pressure shown at the dash panel gauge, but none of the air bag/springs will inflate. Any of these could be the cause EXCEPT a:

- (A) leaking pressure protection valve.
- (B) stuck double-check valve.
- (C) leaking ACC/tank drain valve.
- * (D) stuck left rear height control/leveling valve.

TEST SPECIFICATIONS AND TASK LIST ELECTRICAL/ELECTRONIC SYSTEMS (TEST H6)

Content Area	Questions in Test	Percentage of Test
A. General Electrical/Electronic System Diagnosis	16	32%
B. Battery and Starting System Diagnosis and Repair	12	24%
C. Charging System Diagnosis and Repair	7	14%
D. Lighting Systems Diagnosis and Repair	7	14%
E. Related Vehicle Systems Diagnosis and Repair	8	16%
Total	50	100%

A. General Electrical/Electronic System Diagnosis (16 questions)

1. Verify operator complaint, reproduce the condition (including intermittent problems), and/or road test vehicle; determine necessary action.
2. Check continuity in electrical/electronic circuits using appropriate test equipment.
3. Check applied voltages, circuit voltages, and voltage drops in electrical/ electronic circuits using a digital multimeter (DMM).
4. Check current flow in electrical/electronic circuits and components using an ammeter, digital multimeter (DMM), or a clamp-on ammeter.
5. Check electronic circuit waveforms using an oscilloscope or graphing multimeter (GMM); interpret readings and determine needed repairs.
6. Check resistance in electrical/electronic circuits and components using an ohmmeter or a digital multimeter (DMM).
7. Locate shorts, grounds, and opens in electrical/electronic circuits.
8. Diagnose battery drain problems with the master/key switch OFF.
9. Inspect and test circuit breakers, solid state current limiters, and fuses; replace as required.
10. Inspect and test spike suppression diodes/resistors and capacitors; replace as required.
11. Inspect and test relays and solenoids; replace as required.
12. Read and interpret electrical schematic diagrams and symbols.
13. Read and interpret ladder logic diagrams to diagnose electrical/electronic problems.
14. Read and interpret multiplex diagnostic LEDs; determine needed repairs.
15. Diagnose and repair computer communication multiplex systems; including multiplex controllers, determine needed repairs.

H6 TASK LIST (CONTINUED)

16. Using a laptop computer, establish communication with a multiplex control system. Verify that the needed ladder logic inputs are active to control an individual/specific ladder logic output.
17. Remove, replace, and adjust electrical/electronic switches, sensors, and other electrical/electronic components.
18. Use proper care and handling of electrical/electronic components.
19. Diagnosis failures in the controller area network (CAN) and determine needed repairs.

B. Battery and Starting System Diagnosis and Repair (12 questions)

1. Perform battery load and/or capacitance tests; determine needed repairs.
2. Determine battery state of charge by measuring open circuit voltage (OCV) using a digital multimeter (DMM).
3. Inspect, clean, and service battery, cables, terminal connections, and disconnects; replace as required.
4. Inspect, clean, and repair battery boxes, mounts, and hold downs; replace as required.
5. Charge battery/batteries, using slow or fast charge method as appropriate.
6. Jump-start a transit bus using jumper cables and a booster battery or auxiliary power supply.
7. Perform starter circuit voltage drop tests; determine needed repairs.
8. Inspect and test components of the starter control circuit (master/key switch, push button and/or magnetic switch, and wires); replace as required.
9. Inspect and test starter, relays, and solenoids/switches; replace as required.
10. Remove and replace starter; inspect flywheel ring gear or flex plate.
11. Inspect, clean, repair or replace cranking circuit battery cables and connectors.
12. Differentiate between electrical, multiplex, or mechanical problems that cause a slow cranking, no cranking, extended cranking, or a cranking noise condition.

C. Charging System Diagnosis and Repair (7 questions)

1. Diagnose the cause of no-charge, low-charge, or overcharge conditions; determine needed repairs.
2. Inspect and adjust alternator drive belts/gears, pulleys, fans, air filters, centrifugal air filters, mounting brackets, and tensioners; replace as required.
3. Perform charging system output tests (12 volt and 24 volt); determine needed repairs.
4. Perform charging circuit voltage drop tests; determine needed repairs.
5. Test, adjust, or replace voltage regulator.
6. Maintain, test, repair, remove, and replace alternator.
7. Inspect, repair, or replace charging circuit connectors and wires.
8. Check battery equalizer output, check wiring and mounting; determine needed repairs.
9. Verify operation of charging system circuit monitor; determine needed repairs.
10. Differentiate between electrical, multiplex, or mechanical problems that cause charging system malfunctions.

H6 TASK LIST (CONTINUED)

D. Lighting Systems Diagnosis and Repair (7 questions)

1. Diagnose the cause of brighter than normal, intermittent, dim, or no headlight and daytime running light (DRL) operation.
2. Test, aim, and replace headlights.
3. Test headlight and dimmer switches, wires, connectors, terminals, sockets, relays, and control components; repair or replace as required.
4. Inspect, test, and repair parking, clearance, and taillight circuit switches, bulbs, sockets, connectors, terminals, relays, wires, and light-emitting diodes (LEDs); replace as required.
5. Inspect, test, and repair dash light circuit switches, bulbs, sockets, connectors, terminals, wires, and printed circuits; replace as required.
6. Inspect, test, and repair interior and exterior passenger light circuit switches, bulbs, sockets, connectors, terminals, ballasts/inverters, and wires; replace as required.
7. Inspect and test stoplight circuit switches, bulbs, light-emitting diodes (LEDs), sockets, connectors, terminals, relays, control components, and wires; repair or replace as required.
8. Diagnose the cause of turn signal and hazard light system malfunctions; determine needed repairs.
9. Inspect and test turn signal and hazard circuit flashers or other control components, switches, bulbs, sockets, connectors, terminals, relays, wires, and light-emitting diodes (LEDs); repair or replace as required.
10. Inspect and test backup light and warning devices, circuit switches, bulbs, light-emitting diodes (LEDs), sockets, connectors, terminals, and wires; repair or replace as required.
11. Differentiate between electrical, or multiplex problems that cause lighting system malfunctions.

E. Related Vehicle Systems Diagnosis and Repair (8 questions)

1. Diagnose the cause of intermittent, high, low, or no gauge readings; determine needed repairs.
2. Diagnose the cause of control area network (CAN) driven gauge malfunctions; determine needed repairs.
3. Inspect, test, and adjust gauge circuit sending units, sensors, gauges, connectors, terminals, and wires; repair or replace as required.
4. Inspect and test warning device (lights and audible) circuit sending units, sensors, bulbs, audible components, sockets, connectors, terminals, wires, and printed circuits/control modules; repair or replace as required.
5. Inspect and test electronic speedometer and odometer systems; replace as required; verify proper calibration for vehicle application.
6. Inspect and test horns, horn circuit relays, switches, connectors, terminals, and wires; repair or replace as required.
7. Diagnose the cause of constant, intermittent, or no wiper operation; diagnose the cause of wiper speed control and/or park problems.
8. Inspect and test wiper motor, resistors, park switch, relays, switches, connectors, terminals, and wires; repair or replace as required.

H6 TASK LIST (CONTINUED)

9. Inspect and test windshield washer motor or pump/relay assembly, switches, connectors, terminals, and wires; repair or replace as required.
10. Inspect and test side view mirror motors, heater circuit grids, relays, switches, connectors, terminals, and wires; repair or replace as required.
11. Inspect and test HVAC electrical components including: A/C clutches, motors, resistors, relays, switches, controls, connectors, terminals, and wires; repair or replace as required.
12. Inspect and test engine cooling fan electrical control components; replace as required.
13. Differentiate between electrical, multiplex, or mechanical problems that cause body system component malfunctions.
14. Inspect and test entrance door, controls, solenoids and switches, including hall effect, limit, reed and proximity switches and wires: repair or replace as required. ■

SAMPLE QUESTIONS

ELECTRICAL/ELECTRONIC SYSTEMS (TEST H6)

1. The headlights on a transit bus work OK on low beam, but they are very dim on high beam. Which of these could be the cause?
 - (A) A bad headlight ground
 - (B) A bad ground at the master switch
 - (C) An overloaded circuit breaker
 - * (D) Corroded dimmer switch contacts

2. The operator notices battery odor while the transit bus is being driven. Which of these could be the cause?
 - * (A) The alternator is overcharging.
 - (B) The electrolyte level is low.
 - (C) The battery connections are loose.
 - (D) The alternator drive belt is slipping.

3. Technician A says that a battery equalizer ensures that both batteries charge at the same rate.
Technician B says that a battery equalizer converts 24 volts to 12 volts in a 24-volt/two-battery system.
Who is right?
 - (A) A only
 - (C) Both A and B
 - * (B) B only
 - (D) Neither A nor B

4. A transit bus's windshield wipers work sporadically.
Technician A says that an open (broken) wire could be the cause.
Technician B says that a loose wiring connection could be the cause.
Who is right?
 - (A) A only
 - (C) Both A and B
 - * (B) B only
 - (D) Neither A nor B

H6 SAMPLE QUESTIONS (CONTINUED)

5. An engine will not crank when the start button is pressed, but cranks normally when the starter relay is activated. Which of these is the most likely cause?

- (A) A bad starter solenoid
- * (B) An open between the start button and the relay
- (C) A bad engine ground
- (D) An open between the battery and the relay

6. According to the ladder logic in the schematic shown, the MAG brake solenoid will release only when the:

- (A) wheelchair power is on.
- (B) "hi idle" is on.
- (C) park brake is applied.
- * (D) service brake is applied.

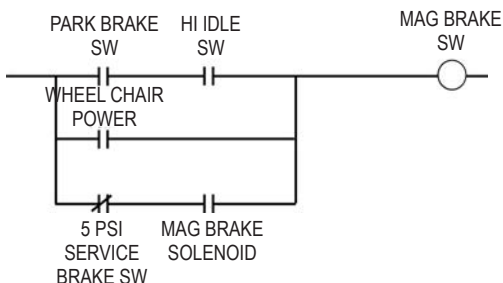

These questions contain the word EXCEPT. Read the questions carefully before choosing your answer.

7. When arc welding on a transit bus, a technician should disconnect all of these EXCEPT the:

- (A) batteries.
- (B) engine control module.
- (C) transmission control module.
- * (D) starter.

8. All of these could cause high starter current draw EXCEPT:

- (A) worn starter bushings.
- * (B) a bad starter relay.
- (C) grounded field coils.
- (D) a grounded armature.

TEST SPECIFICATIONS AND TASK LIST

HEATING, VENTILATION, AND AIR CONDITIONING (TEST H7)

Content Area	Questions in Test	Percentage of Test
A. A/C System and Component Diagnosis, Service and Repair	22	55%
1. A/C System—General (10)		
2. Compressor and Clutch (6)		
3. Evaporator, Condenser, and Related Components (6)		
B. Heating and Engine Cooling Systems Diagnosis, Service and Repair	8	20%
C. Heating, Ventilation, and Air Conditioning Operating Systems and Related Controls Diagnosis and Repair	10	25%
1. Electrical/Electronic Systems (6)		
2. Electronic Temperature Control System (4)		
Total	40	100%

A. A/C System and Component Diagnosis, Service, and Repair (22 questions)

1. A/C System—General (10 questions)

1. Diagnose the cause of A/C system temperature control problems; determine needed repairs.
2. Identify HVAC system components and refrigerant type (R22, R134a, R407c); conduct performance tests; determine appropriate action..
3. Diagnose the cause of A/C system problems indicated by temperature, pressure gauge readings, and sight glass/moisture indicator conditions (where applicable); determine needed service or repairs.
4. Diagnose the cause of A/C system problems by physical conditions (sight, sound, odor, and touch); determine needed repairs.
5. Perform A/C system leak test; determine needed repairs.
6. Evacuate A/C system using appropriate equipment.
7. Check and remove contaminants from the A/C system as needed.
8. Recover and recycle refrigerant; test for non-condensable gases.

H7 TASK LIST (CONTINUED)

9. Charge A/C system with refrigerant.
10. Identify A/C system lubricant type and amount needed for system application.
11. Use a computer and diagnostic software to read /clear fault codes, perform system tests; check and adjust system parameters; reprogram/flash ECM.

2. Compressor and Clutch (6 questions)

1. Inspect, diagnose, and test A/C system for problems that cause protection devices (pressure, thermal, and electronic) to interrupt system operation; determine needed repairs.
2. Inspect, adjust, and align A/C compressor drives, belts, pulleys, and tensioners; replace as required.
3. Inspect, test, and service A/C compressor clutch components and clutch assembly; replace as required.
4. Check and correct A/C compressor lubricant level and condition; drain, refill, and install filter if needed.
5. Inspect and test A/C compressor operation and performance, including loaders and unloaders; check mountings and hardware; replace components as needed.

3. Evaporator, Condenser, and Related Components (6 questions)

1. Check and adjust A/C system lubricant level after replacement of system components.
2. Inspect and repair A/C system hoses, lines, filters, fittings, and seals; replace as required.
3. Check air flow through A/C condensers and evaporators; correct as required.
4. Inspect and test A/C system condenser and mountings; replace as required.
5. Inspect receiver and filter-drier; replace as required.
6. Inspect and test refrigerant solenoid, expansion valve(s), and evaporator pressure regulators; check placement of thermal bulb (capillary tube); replace as required.
7. Inspect and test evaporator core; replace as required.
8. Inspect, clean, and repair evaporator housing and water drain; inspect and service or replace evaporator air filter.
9. Identify and inspect A/C system service valves and connections; repair as required.
10. Diagnose cause of A/C system failures which result in refrigerant loss from the high pressure relief valve.

B. Heating and Engine Cooling Systems Diagnosis, Service, and Repair (8 questions)

1. Diagnose the cause of outlet air temperature control problems in the HVAC system; determine needed repairs.
2. Diagnose window fogging problems; determine needed repairs.
3. Perform engine cooling system tests for leaks, freeze protection level, contamination, coolant level, temperature, and conditioner concentration; determine needed repairs.
4. Inspect engine cooling and heating system hoses, lines, and clamps; replace as required.
5. Inspect and test radiator, pressure relief devices, and coolant recovery system (surge tank); determine needed repairs.
6. Inspect water pump and drive system; determine needed repairs.

H7 TASK LIST (CONTINUED)

7. Inspect and test thermostats, by-passes, housings, and seals; determine needed repairs.
8. Flush and refill cooling system; bleed air from system.
9. Inspect and test fan, fan drives, controls, and fan shroud; repair or replace as required.
10. Inspect and test heating system coolant control valve(s) and manual shut-off valves; replace as required.
11. Inspect and flush driver's heater and/or defroster cores; replace as required.
12. Perform heating system tests to include coolant flow and booster pump(s) operation.
13. Inspect, test, and diagnose heater/defroster and defogger system problems; check blowers, fans, resistors, switches, relay/modules, sensors, wiring, and protection devices; repair or replace as required.
14. Inspect, test and diagnose service heating, ventilating, and defrosting control panel assemblies, cables, and linkages; repair or replace as required.
15. Inspect, test, and diagnose heating, ventilating, and defrosting control switches, hoses, and solenoid valves; repair or replace as required.
16. Inspect, test, and adjust heating, ventilating, and defrosting ducts, filters, doors, hoses, and outlets; repair or replace as required.

C. Heating, Ventilation, and Air Conditioning Operating Systems and Related Controls Diagnosis and Repair (10 questions)

1. Electrical/Electronic Systems (6 questions)

1. Diagnose the cause of failures in HVAC electrical/electronic control systems; determine needed repairs.
2. Inspect and test HVAC defroster blower motors, resistors, switches, relays, modules, wiring, and protection devices; repair or replace as required.
3. Inspect and test HVAC compressor relays, modules, pressure transducers, wiring, sensors, switches, diodes, and protection devices; repair or replace as required.
4. Inspect and test HVAC evaporator/heater and condenser fan motors, motor drivers (alternating current and direct current), relays, modules, switches, sensors, wiring, and protection devices; repair or replace as required.
5. Inspect and test HVAC system electrical/electronic control panel assemblies; repair or replace as required.

2. Electronic Temperature Control Systems (4 questions)

1. Diagnose electronic temperature control system problems; determine needed repairs.
2. Inspect and test climate control temperature sensors; repair or replace as required.
3. Inspect and test coolant valve and controls; repair or replace as required.
4. Inspect and test solenoids and switches; repair or replace as required.
5. Inspect and test electronic temperature control panels and microprocessors; repair or replace as required.
6. Connect computer using diagnostic software to read/clear fault codes and perform system tests; check and adjust system parameters.
7. Inspect and test Controlled Area Network (CAN) for communication integrity. ■

SAMPLE QUESTIONS HVAC (TEST H7)

1. High A/C discharge pressure can be caused by:
 - (A) restricted evaporator coils.
 - * (B) an overcharged system.
 - (C) a defective remote sensing bulb.
 - (D) compressor oil over fill.
2. A technician cannot get a transit bus A/C system to take a refrigerant charge. Which of these could be the cause?
 - (A) Wrong compressor clutch clearance
 - * (B) Suction service valve not mid-seated
 - (C) Compressor speed too low
 - (D) Excessive dirt in the system
3. Removing refrigerant from a system and storing it in a separate container is considered to be:
 - * (A) recovering.
 - (B) evacuating.
 - (C) reclaiming.
 - (D) recycling.
4. An operator says that the HVAC system is not cooling properly. Air is blowing from the vents on one side of the transit bus only. This could be caused by:
 - (A) an undercharged system.
 - * (B) one evaporator fan drive coupling is broken.
 - (C) the evaporator fan is turning too slowly.
 - (D) the compressor clutch is not engaged.
5. Repeated A/C system high pressure hose failures are most likely caused by:
 - (A) extended operation of A/C with a loose drive belt.
 - * (B) incorrect hose installation.
 - (C) an open inside ambient air sensor.
 - (D) extended operation of A/C in high humidity.

H7 SAMPLE QUESTIONS (CONTINUED)

6. Both the suction-side and discharge-side pressures are above normal. This could be caused by:
- (A) a stuck-closed coolant modulating valve.
 - (B) the compressor clutch not disengaging.
 - * (C) a dirty condenser core.
 - (D) a too slow evaporator fan speed.
7. Before being recharged, an A/C system should be evacuated to:
- (A) 29" Hg. for 2 hours.
 - (B) 30" Hg. for 30 minutes.
 - * (C) 500 to 1500 microns for 10 minutes.
 - (D) 2500 to 3000 microns for 30 minutes.
8. Reusable refrigerant cylinders must be hydrostatically tested every:
- (A) year.
 - (B) 3 years.
 - * (C) 5 years.
 - (D) 10 years.
9. An operator complains of a coolant smell while running the defroster. Which of these could be the cause?
- (A) A closed shutoff valve
 - (B) A bad defroster switch
 - * (C) A leak in the defroster core
 - (D) A leak in the evaporator core

This question contains the word EXCEPT. Read the question carefully before choosing your answer.

10. A transit bus has thrown its A/C compressor drive belts for the second time. Any of these could be the cause EXCEPT:
- (A) the compressor's isolator mounts are worn out.
 - (B) the compressor and engine crankshaft pulleys are out of alignment.
 - (C) a weak automatic belt tensioner.
 - * (D) excessive air gap at the A/C clutch armature.

TEST SPECIFICATIONS AND TASK LIST PREVENTIVE MAINTENANCE AND INSPECTION (PMI) (TEST H8)

Content Area	Questions in Test	Percentage of Test
A. Engine Systems	17	34%
B. Body Interior and Exterior	5	10%
C. Electrical/Electronic Systems	9	18%
D. Frame and Chassis	19	38%
Total	50	100%

A. Engine Systems (17 questions)

► Engine

1. Check engine operation for unusual noises, vibration, and exhaust smoke.
2. Inspect crankcase ventilation system.
3. Inspect belts, tensioners, belt guards, pulleys and alignment; check and adjust belt tension; inspect vibration damper.
4. Check engine compartment for oil, coolant, air, hydraulic fluid, fuel and diesel exhaust fluid (DEF) leaks; check oil line routing and mounting (Engine Off and Engine Running).
5. Inspect engine mounts for looseness and deterioration.
6. Check engine oil pressure, oil level and condition; check dipstick seal.
7. Check engine compartment wiring (low and high voltage), harnesses, connectors and seals; check for proper routing and damage; check engine compartment controls, gauges, diagnostic lights and compartment lighting.

► Fuel System

8. Check fuel tanks and mountings, filler neck; check valve mountings, lines, vents, and caps.
9. Drain water and contaminants from fuel system.
10. Inspect water separator/fuel heater; replace fuel filter(s); prime and bleed fuel system.

► Air Induction and Exhaust Systems

11. Inspect diesel emission control systems and components, including exhaust gas recirculation (EGR), catalytic converter, and diesel particulate filter (DPF).
12. Check engine exhaust system mountings for looseness and damage.
13. Check engine exhaust system for leaks, excessive noise, proper routing, and missing or damaged components (heat shields and guards).
14. Check air induction system routing, piping, charge air cooler, hoses, clamps, mountings, and indicators; check for air restrictions and leaks.

H8 TASK LIST (CONTINUED)

15. Inspect turbocharger for noise and leaks; check mountings and connections; check wastegate and controls, variable geometry turbo, linkages, and hoses.
16. Connect diagnostic tool/laptop, check for exhaust system codes, check past repair history, check exhaust aftertreatment health; determine needed actions.
17. Service or replace air filter(s) as required.

► Cooling System

18. Check operation of fan system (including electrical and hydraulic systems); check for hydraulic leaks; inspect wire harness and connectors, inspect fan assembly, fan shroud, and mountings.
19. Inspect radiator and hydraulic oil cooler for air flow restrictions, leaks, and damage; check mountings.
20. Pressure test cooling system and radiator cap. Check cooling system for leaks; determine needed repairs.
21. Inspect all coolant and hydraulic hoses for leaks, damage, and proper routing, check clamp condition and correct installation.
22. Check surge tank, recovery/overflow tanks, and associated hoses; check sight glass for leaks, cracks, and discoloration; verify correct coolant level.
23. Identify coolant type; check coolant for contamination, supplemental additive (SCA) levels, check pH level, and antifreeze concentration level, service coolant filter/conditioner; check condition of shut-off valves.
24. Drain and refill cooling system; bleed air from system; recover coolant.
25. Inspect water pump for leaks and bearing play.

► Lubrication System

26. Change engine oil; visually check oil for coolant or fuel contamination; inspect and clean magnetic drain plugs; torque engine oil pan drain plug to specifications.
26. Change oil filters; service centrifugal oil filter if applicable.
27. Take an engine oil sample.

B. Body Interior and Exterior (5 questions)

► Instruments and Controls

1. Inspect master control switch and start button; check operation of transmission shift selector.
2. Check operation of indicator lights, warning lights and/or alarms.
3. Check operation of instruments, gauges, and panel lighting.
4. Check operation of fast engine idle, throttle and brake interlock systems.
5. Check operation of defroster, heater, ventilation, and A/C (HVAC) controls.
6. Check operation of auxiliary systems, i.e. doors, mirrors, wheelchair lift, kneeling system, and PA system. Check mounting and securement of auxiliary cameras, verify fault monitors.
7. Check operation and condition of accelerator and brake pedals.

► Safety Equipment

8. Check operation of horns.
9. Check condition of safety equipment including flares, reflective triangles, fire extinguisher, and all required decals. Inspect and test fire suppression system.
10. Inspect and test seat belts and wheelchair restraints.

H8 TASK LIST (CONTINUED)

11. Inspect wiper blades and arms.
12. Check windshield wiper and washer operation; verify fluid level.
13. Check for required vehicle permits, registration, decals, and inspection papers.
14. Check operation of emergency exits (roof hatches, windows, door releases, and switches).
15. Check operation of entrance and exit doors, door alarms, sensitive edges, acoustical sensors (if equipped), and touch bars; check door opening and closing speeds; check operation of brake interlocks.

► Hardware

16. Inspect windshield glass for cracks, chips or discoloration; check sun shade/visor operation.
17. Check driver's seat condition, operation (including seat sensor if equipped), mounting, and suspension components.
18. Check passenger seat condition, operation, and mountings. Verify American with Disabilities Act (ADA) seat operations, including latches, straps, and switches; service as required.
19. Check door glass and passenger window operation, condition (including anti-graffiti window liners), and safety stops.
20. Inspect condition and mountings of steps, flooring, stanchions, grab rails, grab straps, and overhead panels.
21. Inspect mirrors, mountings, brackets, glass heaters, and motors.
22. Inspect and record interior and exterior damage.
23. Inspect and lubricate door and compartment hinges, latches, strikers, gas struts, linkages, and cables, if applicable.
24. Inspect bicycle rack operation, condition, and mounting.
25. Check fare box physical condition and mounting.

► Heating, Ventilation, and Air Conditioning (HVAC)

26. Inspect A/C condenser and evaporator and lines for routing, condition, and visible leaks.
27. Inspect A/C compressor and lines for routing, condition, and visible leaks; check compressor mountings; check drive belt condition, tension, and alignment. Check for unusual noise; determine needed repairs.
28. Check operation of condenser and evaporator motors.
29. Check HVAC system operation, including checking display panel for alarm codes.
30. Check HVAC air inlet filters and ducts; service as required.
31. Check booster pump and coolant control valves operation.
32. Check operation of auxiliary coolant heater system; check for leaks (coolant and fuel) and damage.

C. Electrical/Electronic Systems (9 questions)

► Battery and Starting Systems

1. Inspect and lubricate battery compartment doors, hinges, trays, slides, covers, latches, and mountings.
2. Inspect battery disconnect switch, hold downs, connections, cables, and cable routing; service as required.

H8 TASK LIST (CONTINUED)

3. Check battery condition and record battery state of charge (open circuit voltage); check electrolyte level (if applicable).
4. Perform battery load tests.
5. Inspect starter, mounting, connections, cables, and cable routing; inspect hoses, and hose routing for air starters.
6. Engage starter; check for unusual noises, starter drag, and starting difficulty.

► Charging System

7. Inspect charging system mountings, wiring and routing.
8. Perform charging system output test (12V and 24V); determine needed repairs.
9. Check equalizer function, wiring, and mountings.

► Lighting and Alarm Systems

10. Check operation and condition of interior lights.
11. Check operation and condition of exterior lights, lenses, and reflectors; check headlight alignment.
12. Inspect and check operation of exterior warning systems (backup, wheelchair, kneeling).
13. Check condition and operation of passenger stop request light and chime (including all pull cords and switches).
14. Inspect and check operation of destination signs and block/route signs.
15. Use a diagnostic tool or the on-board diagnostic system to extract engine, transmission, brake monitoring, and other vehicle diagnostic systems information and codes.

D. Frame and Chassis (19 questions)

► Air Brakes

1. Check parking brake operation.
2. Check and record air governor cut-in and cutout settings (psi); check air pressure build-up time.
3. Check operation of air drier purge valve and heater; service air drier as required; check system for contamination.
4. Check air system for leaks (brakes released and applied).
5. Test single-check and double-check valves.
6. Check low air pressure warning devices and air-actuated pressure switches (brake light, retarder, etc).
7. Test emergency spring brake control valve (SR-1, SR-7).
8. Measure brake interlock application pressure.
9. Perform antilock brake system (ABS) operational self-test; perform automatic traction control (ATC) operational self-test.
10. Inspect air lines, couplings, fittings, air tanks, and mountings.
11. Check brake chambers and air lines for secure mountings, damage, and missing caging plugs.
12. Inspect and record brake lining/pad condition and thickness on all axles.
13. Inspect condition of brake drums/rotors on all axles.
14. Check operation of automatic slack adjusters on all axles; measure and record pushrod travel at each wheel end.

H8 TASK LIST (CONTINUED)

15. Check operation and condition of brake calipers and mountings.
16. Check operation and condition of foundation brake components and hardware on all axles.
17. Lubricate air brake system component grease fittings.

► Drive Train

18. Inspect transmission/hybrid drive unit case, seals, filter(s), retarder components, cooler, and cooler lines for cracks, leaks, and routing.
19. Inspect transmission/hybrid drive unit wiring, connectors, seals, and harnesses for damage and routing.
20. Inspect and service Energy Storage System (ESS) filter(s).
21. Inspect transmission/hybrid drive unit breather; service as required.
22. Inspect transmission/hybrid drive unit mounts for looseness and deterioration.
23. Check transmission/hybrid drive unit oil/fluid level and condition.
24. Inspect U-joints, slip joints, yokes, and drivelines for looseness, damage, and correct phasing.
25. Inspect axle housing for cracks and leaks.
26. Inspect axle breather; service as required.
27. Lubricate drive train grease fittings.
28. Check drive axle and planetary hubs for correct oil level.
29. Change drive axle and planetary hub oil; check and clean magnetic plug.
30. Change transmission/hybrid drive unit oil/fluid and filters; check and clean magnetic plug, torque transmission oil pan drain plug and/or transmission filter bolts.
31. Take transmission/hybrid drive unit oil/fluid sample.

► Suspension and Steering Systems

32. Check steering wheel operation for free play or binding; check tilt and telescoping operations and condition.
33. Check hydraulic and/or power steering pump and hoses for leaks and mounting; check fluid level and condition.
34. Change hydraulic and/or power steering fluid and filter(s).
35. Inspect steering gear and miter box for leaks and mounting.
36. Inspect steering shaft and U-joints for condition and phasing; inspect pinch bolts, splines, Pitman arm-to-steering sector shaft, steering/Ackerman arms, drag link, tie rod ends and wheel stops.
37. Check for kingpin and thrust bearing wear.
38. Check wheel bearings for adjustment and noise.
39. Check oil level and condition of non-drive axle hubs; check for leaks.
40. Inspect suspension components (torque rods, lateral rods).
41. Inspect shock absorbers for leaks and mounting.
42. Inspect air suspension components for leaks and damage.
43. Check suspension ride height.
44. Lubricate suspension and steering system grease fittings.

► Tires and Wheels

45. Inspect tires for irregular wear patterns and proper mounting.
46. Inspect tires for cuts, exposed cords, cracks, bulges, and sidewall damage.

-
47. Inspect valve caps and stems.
 48. Measure and record tire tread depth; check and record tire air pressure.
 49. Inspect for loose or missing lug nuts; torque lug nuts; check mounting hardware condition.
 50. Inspect wheels and spacers for cracks and damage.
 51. Check tire matching (diameter and tread), and valve stem positioning on dual tire installations.

► **Frame, Under Floor and Rooftop Mounted Equipment**

52. Check mud flaps, skirts, and brackets.
53. Check articulation joint mounts, bushings, rollers, cylinders, switches and sensors (alarm proximity, pressure); check articulation joint hydraulic pressures where applicable; inspect bellows/curtains for damage or tears; inspect articulation joint steering linkage and operation; torque articulation joint fasteners as required; lubricate articulation joint grease fittings.
54. Inspect frame and frame members for cracks and damage.
55. Inspect body-attaching hardware.
56. Check operation and condition of wheelchair lift/ramps, interlocks, chains, bushings, sensitive edges, sensors, proximity switches and hoses; check fluid level; lubricate grease fittings and chains if applicable.
55. Check mounting security of under floor and rooftop mounted equipment. ■

SAMPLE QUESTIONS

PREVENTIVE MAINTENANCE AND INSPECTION (PMI) (TEST H8)

1. When the driveline spline is being lubed, the PM technician should see grease coming out is the:
 - (A) yoke.
 - * (B) relief hole.
 - (C) seal.
 - (D) U-joint.

2. During a PMI, coolant is found under the vehicle and the reservoir is low. The PMI technician should:
 - (A) add coolant and replace the coolant reservoir cap.
 - * (B) pressure-test the system to find a leak.
 - (C) run the engine to check the cooling fan operation.
 - (D) run the engine at operating temperature to find a leak.

3. When performing a load test on a multiple battery system, which of these operations should the PM technician perform first?
 - (A) Clean the battery cables.
 - (B) Start the engine.
 - * (C) Isolate the batteries.
 - (D) Remove the surface charge.

4. Technician A says that if the compressor cutout pressure is too high, the air governor should be adjusted.
Technician B says that if the difference between cutout and cut-in is excessive, the air governor should be adjusted.
Who is right?
 - * (A) A only
 - (B) B only
 - (C) Both A and B
 - (D) Neither A nor B

H8 SAMPLE QUESTIONS (CONTINUED)

5. During a PMI, the PM technician finds a green eye on each of the batteries. This indicates that the batteries are:
- (A) serviceable at this time.
 - (B) bad and need to be replaced.
 - * (C) ready to be tested.
 - (D) marginal, and should be charged.
6. During a PM inspection, excessive serpentine belt wear was detected. Technician A says that improper belt tension could be the cause. Technician B says that misaligned pulleys could be the cause. Who is right?
- (A) A only
 - (B) B only
 - * (C) Both A and B
 - (D) Neither A nor B
7. Which air tank should be drained when testing the emergency spring brake valve?
- (A) Accessory tank
 - (B) Wet tank
 - * (C) Primary tank
 - (D) Secondary tank

This question contains the word EXCEPT. Read the question carefully before choosing your answer.

8. When inspecting the wheels, the PM technician should check for all of these EXCEPT:
- (A) rust trails from the lug nuts.
 - (B) proper hand hole alignment.
 - (C) cracks radiating from the stud holes.
 - * (D) paint flaking from the rim.

TEST PREP & TRAINING

Taking an ASE certification test doesn't have to be a high stress challenge. The ASE website contains test preparation and training information tailored to your specific needs. Visit www.ase.com and use the "Test Prep & Training" tab. We've loaded this section of our website with plenty of information to help boost both your knowledge and your confidence—two of your most important tools as a test-taker.

Official ASE Practice Tests

The easy way to try your hand at taking ASE-style certification exams, without the stress and high stakes of the real thing.

Test Taking Tips

An easy, self-guided introduction to taking your ASE certification test, including examples of the types of questions you'll see and proven tips for success.

Study Guides

Free, step-by-step guides to help you understand what's involved in each test including sample questions and suggestions for further preparation.

CBT Test-Drive

Not familiar with ASE's computer based tests? This self-paced presentation will show you how they work, so you'll feel right at home with the testing format.

In-service Training Providers

You can choose from a variety of training programs, both instructor led and self-directed, that have been evaluated through a quality-assurance process called CASE (Continuing Automotive Service Education) and accredited by ASE.

Community Colleges and Technical Training Schools

Get instructor-led, hands-on training at schools accredited by the National Automotive Technician Education Foundation.

ATMC for more training options

The Automotive Training Manger Council is a professional organization of individuals responsible for the development and delivery of training in the auto and truck industries and a member of the ASE Industry Education Alliance. The ATMC administers the Continuing Automotive Service Education (CASE) program for the ASE accreditation of training providers serving the transportation industry. A list of CASE accredited training providers can be found at the ATMC website. www.atmc.org

Other test prep and training programs

Many test-takers have used aftermarket test prep and training programs and found them helpful. Please note that ASE has neither reviewed nor approved the content of these programs and providers.



COPYRIGHT © 2017 by

National Institute for

AUTOMOTIVE SERVICE EXCELLENCE

All rights reserved



National Institute for

AUTOMOTIVE SERVICE EXCELLENCE

101 Blue Seal Dr., S.E., Suite 101
Leesburg, VA 20175

To contact us:

703-669-6600

www.ase.com