



Service Bulletin

EGC1500C2/EGC1250C2 Fan Replacement

Product Group: Power Solutions	Date Issued: 01/26/2011	Service Bulletin No. GSP20110126																											
Bulletin Type		Models/Series Affected:																											
<input checked="" type="checkbox"/> Mandatory <input type="checkbox"/> Information Only <input type="checkbox"/> Recommended Change		EGC1500C2 <table border="1"> <tr> <td>WA-566888-0908</td> <td>WA-562490-1207</td> <td>WA-571154-1109</td> <td>X07M520360</td> <td>X08C110806</td> </tr> <tr> <td>WA-560675-1007</td> <td>WA-566893-0908</td> <td>WA-563507-0408</td> <td>X08C110803</td> <td>WA-566908-0908</td> </tr> <tr> <td>WA-567038-1008</td> <td>WA-566899-0908</td> <td>WA-562394-0408</td> <td>X8A030654</td> <td></td> </tr> </table> EGC1250C2 <table border="1"> <tr> <td>WA-564238-0208</td> <td>WA-563766-0208</td> <td>WA-564196-0208</td> <td>WA-564226-0208</td> <td>F080189849</td> </tr> <tr> <td>WA-564198-0208</td> <td>WA-563762-0208</td> <td>WA-564267-0308</td> <td>WA-564149-0208</td> <td></td> </tr> </table>			WA-566888-0908	WA-562490-1207	WA-571154-1109	X07M520360	X08C110806	WA-560675-1007	WA-566893-0908	WA-563507-0408	X08C110803	WA-566908-0908	WA-567038-1008	WA-566899-0908	WA-562394-0408	X8A030654		WA-564238-0208	WA-563766-0208	WA-564196-0208	WA-564226-0208	F080189849	WA-564198-0208	WA-563762-0208	WA-564267-0308	WA-564149-0208	
WA-566888-0908	WA-562490-1207	WA-571154-1109	X07M520360	X08C110806																									
WA-560675-1007	WA-566893-0908	WA-563507-0408	X08C110803	WA-566908-0908																									
WA-567038-1008	WA-566899-0908	WA-562394-0408	X8A030654																										
WA-564238-0208	WA-563766-0208	WA-564196-0208	WA-564226-0208	F080189849																									
WA-564198-0208	WA-563762-0208	WA-564267-0308	WA-564149-0208																										

Details

Problem:

During normal operation, the fan is spinning at 990 rpm, and harmonic distortion causes the fan to vibrate. Excessive fan vibration may cause the fan blades to fail.

Solution:

Replace fan and shroud. Refer to Instructions P/N 55738 for procedure.

Parts Information

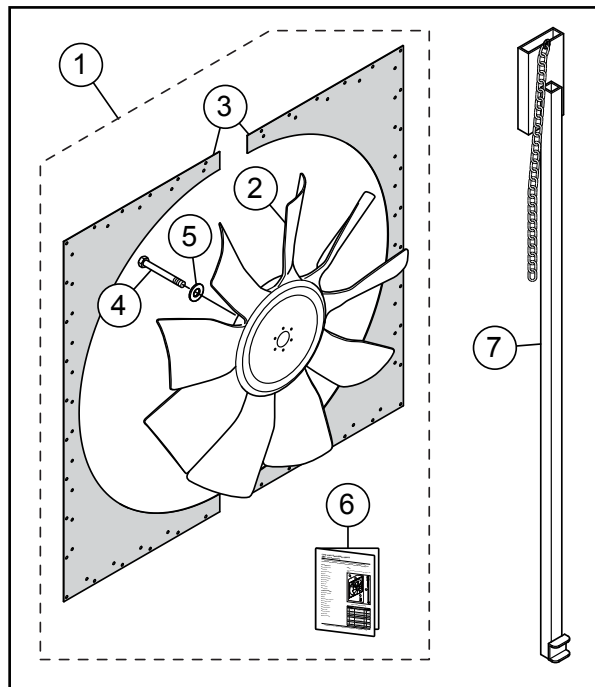

Figure 1. Fan Replacement Parts

Item No.	Part No.	Description	QTY.	Remarks
1	EE55730	Kit, Fan Replacement	1	Includes items 2-6
2	EE55375	Fan, 60 in.	1	
3	EE55376	Shroud, Left and Right	1	
4		Bolt, 1/2-13 x 7", Hex Head, Zinc Plated, Gr. 8.	6	
5		Washer, Flat, 1/2", Gr. 8.	6	
6	55738	Instructions, EGC1500C2/EGC1250C2 Fan Replacement	1	
7	EE55744	Fork Extension Tool	1	



Service Bulletin

EGC1500C2/EGC1250C2 Fan Replacement

HERE'S HOW TO GET HELP

PLEASE HAVE THE MODEL AND SERIAL
NUMBER ON-HAND WHEN CALLING

UNITED STATES

Multiquip Corporate Office

18910 Wilmington Ave. Tel. (800) 421-1244
Carson, CA 90746 Fax (800) 537-3927
Contact: mq@multiquip.com

Service Department

800-421-1244 Fax: 310-537-4259
310-537-3700

Technical Assistance

800-478-1244 Fax: 310-943-2238

MQ Parts Department

800-427-1244 Fax: 800-672-7877
310-537-3700 Fax: 310-637-3284

Warranty Department

800-421-1244 Fax: 310-943-2249
310-537-3700

MEXICO

MQ Cipsa

Carr. Fed. Mexico-Puebla KM 126.5 Tel: (52) 222-225-9900
Momoxpan, Cholula, Puebla 72760 Mexico Fax: (52) 222-285-0420
Contact: pmastretta@cipsa.com.mx

CANADA

Multiquip

4110 Industriel Boul. Tel: (450) 625-2244
Laval, Quebec, Canada H7L 6V3 Tel: (877) 963-4411
Contact: jmartin@multiquip.com Fax: (450) 625-8664

UNITED KINGDOM

Multiquip (UK) Limited Head Office

Unit 2, Northpoint Industrial Estate, Tel: 0161 339 2223
Globe Lane, Fax: 0161 339 3226
Dukinfield, Cheshire SK16 4UJ
Contact: sales@multiquip.co.uk

© COPYRIGHT 2011, MULTIQUIP INC.

Multiquip Inc and the MQ logo are registered trademarks of Multiquip Inc. and may not be used, reproduced, or altered without written permission. All other trademarks are the property of their respective owners and used with permission.

The information and specifications included in this publication were in effect at the time of approval for printing. Illustrations, descriptions, references and technical data contained in this document are for guidance only and may not be considered as binding. Multiquip Inc. reserves the right to discontinue or change specifications, design or the information published in this publication at any time without notice and without incurring any obligations.

Your Local Dealer is:

