



Number: SB121028
Date: 07/24/07
Model: CXU, CXP, CXN,
 CHU, CHN, GU,
 CTP, CT

(Also applies to Mack Trucks Australia)
 (Supersedes SB121028 dated 08/05/04)

14 MM Huck-Spin® Frame Fasteners

With the introduction of the MACK Advantage™ model chassis, Mack Trucks, Inc. began using 14 mm Huck-Spin® frame fasteners in production. These fasteners are the primary fastener used on the Advantage™ chassis, and are used to attach 90% of all chassis components to the frame, including the front and rear suspension brackets, and the crossmembers.

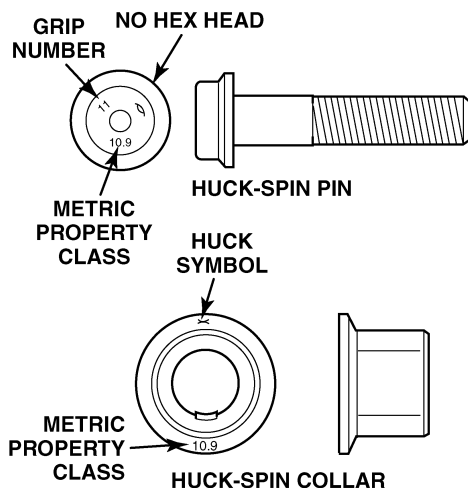

101632a

Figure 1 — Huck-Spin® Pin and Collar

Currently, Huck-Fit® fasteners are the fasteners available through the MACK Parts System for all field service frame repairs. Huck® International, however, will not produce 14 mm Huck-Fit® fasteners, requiring dealers who perform frame repairs to purchase the necessary installation tools for the 14 mm Huck-Spin® fasteners. If a dealership already has Huck-Fit® installation equipment, they should have either the 940 or 943 hydraulic power unit. If this is the case, it will only be necessary to purchase the hydraulic installation tool (tool No. 2624HS) and the 14 mm Huck-Spin® nose assembly (tool No. 99-7511). If a dealership does not have any Huck® installation equipment and is planning on purchasing the tools, two different kits (M14 Small Rig Kit and M14 Large Rig Kit) are available. Kits, tools and accessories are as follows:

Tool Part No.	Description
2624HS and 99-7511	Hydraulic installation tool and nose assembly for 14 mm Huck-Spin® frame fasteners (for dealers who already have either a 940 or 943 hydraulic power unit)
M14 Small Rig Kit	Kit includes hydraulic installation tool (2624HS), nose assembly (99-7511) for 14 mm diameter pins, power unit (964) and 15 ft. of hose.
M14 Large Rig Kit	Kit includes hydraulic installation tool (2624HS), nose assembly (99-7511) for 14 mm diameter pins, power unit (940) and 15 ft. of hose.

NOTE

The difference between the 964 and 940 power units is the amount of time it takes to install one fastener.

- 940 power unit takes 4 seconds to swage one fastener
- 964 power unit takes 42 seconds to swage one fastener

Nose assemblies and collar cutters for the various other Huck-Spin® fasteners are also available. Part numbers are as follows:

Tool Part No.	Description
99-7511	14 mm installation nose
99-7511CC	14 mm collar cutter
99-7501	16 mm installation nose
99-7501CC	16 mm collar cutter
99-7512	20 mm installation nose
99-7512CC	20 mm collar cutter

Due to the increased demand for Huck-Spin® fasteners, Huck® International indicates that Huck-Fit® fasteners will eventually be discontinued, and only Huck-Spin® fasteners will be available for both production and service. This should be considered by any dealer who is planning on purchasing Huck® fastener installation equipment.

To support the change to 14 mm Huck-Spin® frame fasteners, Huck® International has established a nationwide network of distributors who have agreed to maintain adequate inventory of all the installation tools described in this bulletin. Following is the list of Huck® distributors who should be contacted directly for all Huck® installation tool and accessory pricing and purchases.



Stocking and Servicing Distributors in the United States

<p>Arkansas Central Fastening Systems 801 McCann Road Rogers, AR 72758 Telephone: 888 370 1894 Fax: 479 636 2119</p>	<p>Illinois L.A. Fasteners 7936 W. 47th St. Lyons, IL 60534 Telephone: 800 837 8707 Fax: 708 447 7796</p>	<p>Ohio Spencer Products 1181 Hillsmith Drive Cincinnati, OH 45215 Telephone: 513 771 6821 Fax: 513 771 1202</p>
<p>Arizona Duncan Bolt Company 4026 E Broadway, Ste 902 Phoenix, AZ 85040 Telephone: 602 426 1422 Fax: 602 426 1425</p>	<p>Illinois O.K. Fasteners, Inc. 815 Industrial Drive Troy, IL 62294 Telephone: 800 841 7293 Fax: 618 667 2903</p>	<p>Pennsylvania JPC Specialties 6152 Keystone Ave Philadelphia, PA 19135 Telephone: 800 220 4404 Fax: 215 331 7795</p>
<p>California Dean Lewis Associates 21650 Cloud Way Hayward, CA 94545 Telephone: 510 785 9650 Fax: 510 786 3180</p>	<p>Indiana Spencer Products Company 2421 S. Nappanee St, Ste D Elkhart, IN 46517 Telephone: 574 294 3502 Fax: 574 296 0638</p>	<p>Texas Allied Bolt & Supply 1111 Denton Way Dallas, TX 75229 Telephone: 972 243 1212 Fax: 972 484 5236</p>
<p>California Duncan Bolt 8535 Dice Rd. Santa Fe Springs, CA 90670 Telephone: 800 798 1939 Fax: 562 698 8831</p>	<p>Minnesota Charter, Inc. 3757 Dunlap Street No. Arden Hills, MN 55112-6934 Telephone: 651 636 8010 Fax: 651 636 7540</p>	<p>Texas Byler Rivet Supply 2118 Parkside Ave Irving, TX 75061 Telephone: 800 325 3147 Fax: 972 986 2832</p>
<p>Colorado Kemper Products 11603 Teller St. Broomfield, CO 80020 Telephone: 303 466 1494 Fax: 303 466 0048</p>	<p>New York Bay Fastening Systems 263 Park Ave. Garden City Park, NY 11040 Telephone: 800 718 8818 Fax: 516 294 3448</p>	<p>Texas Nappco Fasteners 11260 Hempstead Hwy Houston, TX 77092 Telephone: 800 580 9515 Fax: 713 957 4315</p>
<p>Florida J.O. King, Inc. 5015 Rio Vista Ave. Tampa, FL 33634 Telephone: 800 282 7127 Fax: 813 882 3167</p>	<p>North Carolina J.O. King, Inc. 8041-B Arrowridge Blvd. Charlotte, NC 28273 Telephone: 800 333 5058 Fax: 704 529 0990</p>	<p>Texas Nappco Fasteners 4901 Whirlwind Drive San Antonio, TX 78217 Telephone: 800 580 9515</p>
<p>Florida Spencer Products Company 5144 Cypress St. Tampa, FL 33607 Telephone: 813 289 9462 Fax: 813 289 1570</p>	<p>North Carolina Spencer Products Suite 0, 10701 S. Commerce Blvd. Charlotte, NC 28273 Telephone: 704 333 6601 Fax: 704 342 3501</p>	<p>Texas Nappco Fasteners 2540 Brockton - Suite 108 Austin, TX 78758 Telephone: 800 580 9515</p>
<p>Georgia J.O. King, Inc. 1265 Old Alpharetta Rd. Alpharetta, GA 30202 Telephone: 800 241 2681 Fax: 770 442 0950</p>	<p>Ohio Spencer Products 1859 Summit Commerce Pk Twinsburg, OH 44087 Telephone: 330 487 5200 Fax: 330 487 1111</p>	<p>Washington Dean Lewis Associates 7105-A N.E. 40th Ave Vancouver, WA 98661 Telephone: 360 693 6211 Fax: 360 695 9740</p>



Stocking and Servicing Distributors in Canada and British Columbia

British Columbia Mattic Industries #204 13395 76 Ave. Surrey BC V3W6K2 Telephone: 604 594 7500 Fax: 604 594 4605	Saskatchewan, Manitoba and NW Ontario Applifast Inc 251 Cree Crescent Ave. Winnipeg Manitoba R3J3X4 Telephone: 204 837 8361 Fax: 204 837 3520	Ontario Pro Fast Inc 1341 Main Street East Hamilton Ontario L8K 1B6 Telephone: 905 549 4638 Fax: 905 549 4690
Alberta Mattic Industries 79421 51 st SE Calgary Alberta T2C4R2 Telephone: 403 219 0600 Fax: 403 219 0601	Ontario Ace Rivet Inc 34 Strathern Brampton Ontario L6T4L8 Telephone: 905 792 2255 Fax: 905 792 1529	Quebec and Maritimes Davanac Inc 1936 St Regis Dorval Quebec H9P 1H6 Telephone: 514 421 0177 Fax: 514 421 0188

Mack Trucks, Inc. recognizes that Huck® fastening systems are the most effective method of maintaining clamp force on all frame joints without the need for any additional maintenance requirements.

The following chart provides 14 mm Huck-Spin® pin and collar part numbers, grip numbers and ranges and installation tool numbers.

Pin Diameter (mm)	Pin Part No.	Collar Part No.	Grip No.	Grip Range in mm (inches)	Installation Tool Nose No.	Installation Tool No.
14	4AM34	159AM5	10	4–19 (0.12–0.75)	99-7511	2624HS
14	4AM36	159AM5	20	14–29 (0.55–1.14)	99-7511	2624HS
14	4AM37	159AM5	25	19–34 (0.75–1.34)	99-7511	2624HS
14	4AM38	159AM5	30	24–39 (0.95–1.54)	99-7511	2624HS
14	4AM39	159AM5	35	29–44 (1.14–1.73)	99-7511	2624HS
14	4AM40	159AM5	40	34–49 (1.34–1.93)	99-7511	2624HS
14	4AM41	159AM5	45	39–54 (1.54–2.13)	99-7511	2624HS
14	4AM42	159AM5	50	44–59 (1.73–2.32)	99-7511	2624HS
14	4AM43	159AM5	55	49–64 (1.93–2.52)	99-7511	2624HS
14	4AM44	159AM5	60	54–69 (2.13–2.72)	99-7511	2624HS
14	4AM45	159AM5	65	59–74 (2.32–2.91)	99-7511	2624HS
14	4AM46	159AM5	70	64–79 (2.52–3.11)	99-7511	2624HS
14	4AM47	159AM5	75	69–84 (2.72–3.31)	99-7511	2624HS