

SVS-04-09
2/12/2009**TO: ALL DISTRIBUTOR & DEALER SERVICE PERSONNEL****SUBJECT: POTENTIAL OIL LEAK – 4L SERIES ENGINE GEAR CASE PTO SHIPPING COVER****BACKGROUND INFORMATION**

Isuzu engines are designed to have the gear case PTO port utilized; however, this port may not be utilized in some circumstances. The gear case PTO port is shipped from the factory with a loosely fitted cover. It can be used as a permanent cover; however, it **must** be re-sealed and tightened or otherwise an oil leak may occur.

MODELS AFFECTED

All 4L-series engine models with a gear case PTO.

ACTION REQUIRED

Inspect gasket for reuse; if reusable, re-install with sealant and torque to 41-55N·m. If the gasket is **not** reusable, replace with an appropriate **new** Isuzu gasket and re-install with sealant; then torque fasteners to 41-55N·m.

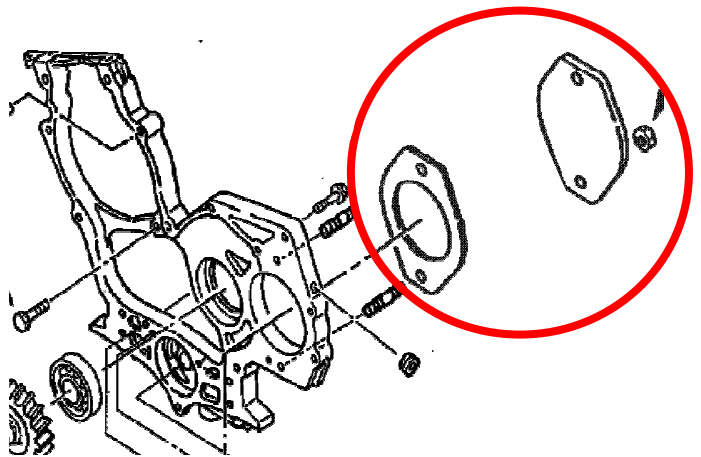
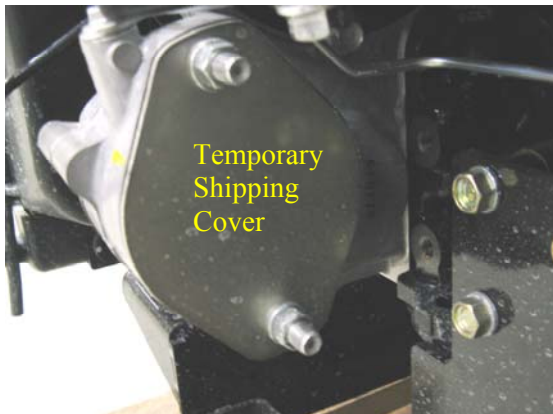

Please note that this is not a warrantable repair.

If you should have any questions please contact your Isuzu Service Representative.

Best Regards,
Your **Isuzu PT** Service Team