



This service bulletin replaces bulletin 258-27 dated 3.2016.

Date	Group	No.	Release	Page
1.2017	258	27	06	1(30)

Aftertreatment System, Design and Function MP7 US2010, MP8 US2010, MP10 US2010

Aftertreatment System, Design and Function

This service bulletin describes the design and function of the exhaust aftertreatment systems used on US2010 and US2014 emissions MACK vehicles. These systems include the exhaust gas recirculation (EGR) system, the aftertreatment diesel particulate filter (DPF) system, and the aftertreatment selective catalytic reduction (SCR) system.

Note: Information is subject to change without notice.
Illustrations are used for reference only and can differ slightly from the actual vehicle being serviced. However, key components addressed in this information are represented as accurately as possible.

Design and Function

Exhaust Aftertreatment System, (EATS)

The aftertreatment system consists of engine and exhaust components and sensors that work together to lower emissions to meet the US2010 emission requirements for the heavy truck industry. This bulletin describes the main aftertreatment systems and components, such as the aftertreatment diesel particulate filter (DPF) system, the exhaust gas recirculation (EGR) system and the aftertreatment selective catalytic reduction (SCR) system, and how they work together to lower emissions and improve fuel economy.

System Components and Operations

Exhaust Gas Recirculation (EGR) System

The EGR system is designed to recirculate exhaust gases into the combustion chambers to reduce the nitrogen oxide (NOx) emissions.

The NOx content increases with higher combustion temperatures. Recirculating cooled exhaust gases reduces the temperature in the combustion chamber and lowers the level of NOx emissions. To do this, the pressure must be higher in the exhaust side than in the inlet side and is controlled by the variable geometry engine turbocharger (VGT).

An EGR valve is mounted on the exhaust manifold. This valve is controlled by the engine control module (ECM) and operated by oil pressure. The EGR valve regulates the recirculation of exhaust gases.

A portion of the exhaust gas is redirected through the EGR valve from the exhaust manifold and into the EGR cooler. The exhaust gas then goes through the Venturi tube, where the EGR differential pressure sensor measures the gas flow, and into the EGR mixing chamber. There, the exhaust gas is mixed with intake air cooled by the charge air cooler (CAC) before it enters the intake manifold.

The amount of recirculated exhaust gases is controlled by the ECM and depends on engine load, engine coolant temperature (ECT) and other various factors.

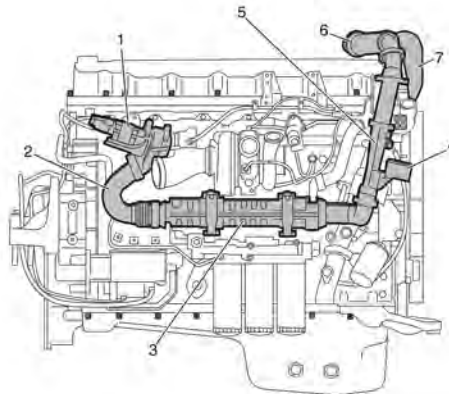

W2005851

- 1 EGR Valve
- 2 EGR Valve Outlet Pipe
- 3 EGR Cooler
- 4 EGR Differential Pressure Sensor
- 5 Venturi Tube
- 6 Crossover Pipe
- 7 EGR Mixing Chamber

Engine Variable Geometry Turbocharger (VGT)

The EVGT regulates the charge air pressure and drives the exhaust gas recirculation (EGR) system. The engine turbocharger lowers emissions, provides optimum fuel consumption and increases power output. The speed of the gases entering the turbine controls the engine turbocharger function. The gas speed is controlled by an electronic actuator. Engine coolant helps cool the engine turbocharger bearing housing and the actuator.

The EVGT has a set of vanes and a sliding nozzle ring that maintain sufficient back pressure in the exhaust manifold to allow proper operation of the EGR system. Back pressure is required to push the exhaust gases into the pressurized intake air at the EGR mixer.

The engine turbocharger sliding nozzle ring controls the exhaust back pressure for proper operation of the EGR system and for enhanced braking. When the variable geometry nozzle mechanism is closed, the engine turbocharger performs as an exhaust brake.

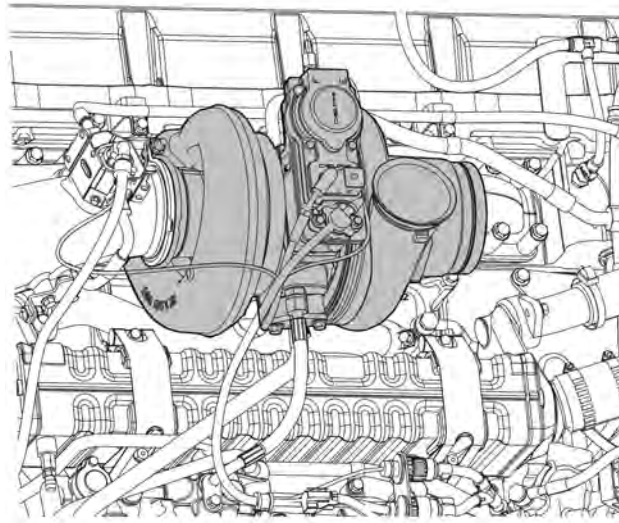

W2005653

Aftertreatment Diesel Particulate Filter (DPF) System

Simplified Concept

US2010 emissions engines utilize an aftertreatment diesel particulate filter (DPF) system to meet US2010 emissions particulate matter regulations. The engine exhaust contains particulate matter, most of which gets trapped in the aftertreatment DPF. Eventually, the particulate matter has to be oxidized (burned). The aftertreatment DPF system design uses the following two methods to oxidize accumulated particulate matter.

- Aftertreatment DPF Passive Regeneration
- Aftertreatment DPF Forced Stationary Regeneration using the aftertreatment hydrocarbon doser when passive regeneration is insufficient

The system maximizes aftertreatment operating conditions for passive regeneration while maintaining the system's ability to begin forced stationary regeneration when it is required. Forced stationary regeneration is a backup when passive regeneration is insufficient. The intention is to minimize the number of forced stationary regenerations.

Strategy

Passive regeneration occurs when the exhaust gas temperature (EGT) at the DPF inlet and the NO_x to particulate matter ratio are high enough to oxidize the particulate matter. Passive regeneration is a slow reaction. Once it starts it can be a continuous process.

Forced stationary regeneration is a faster reaction that takes approximately 25 minutes to completely oxidize accumulated particulate matter. The engine control module ECM controls forced stationary regeneration with input from the aftertreatment control module (ACM). The ECM determines when to begin a forced stationary regeneration, controls the correct fuel quantity from the aftertreatment hydrocarbon doser based on temperature limits, and determines when to end a forced stationary regeneration. A heat mode is activated that allows the EGT to rise to the minimum temperature needed for a forced stationary regeneration.

For non-spark assisted DPF systems, the ECM determines when to begin an active regeneration, controls the correct fuel quantity from the aftertreatment hydrocarbon doser based on temperature limits, and determines when to end an active regeneration. If required, a heat mode is activated that allows the EGT to rise to the minimum temperature needed for an active regeneration.

Activation

When passive regeneration occurs the driver is not aware of it. Passive regeneration does not change engine operation.

Forced stationary regeneration has to be started by the driver with a dashboard switch when a warning light flashes and a "regeneration needed" message is displayed. The driver can not start forced stationary regeneration without notification from the engine.

Deactivation

- Passive regeneration: ignition key in the OFF position
- Forced stationary regeneration: ignition key in the OFF position or parking break OFF, vehicle speed greater than 2 km/hr (1 mph), gear engaged/pedal

After-Market Service



WARNING

The service technician must make sure that the vehicle is in a safe location. The high temperatures created during the aftertreatment DPF regeneration process can cause a fire if flammable materials are too close to the exhaust pipe or muffler. Serious personal injury can result and the vehicle or equipment can be damaged.



CAUTION

The following precautions should be considered before handling the diesel particulate filter (DPF) components:

- A. Wear suitable eye protection.
- B. Wear suitable overalls or apron and heavy-duty gloves to avoid skin contact.
- C. Wear suitable respirator to avoid inhalation.
- D. Ensure adequate ventilation.

Ash is the residue from the noncombustible part of the particulate matter and accumulates in the filter. Lubrication oil consumed by the engine is usually the source of ash. Filters must be cleaned or replaced to avoid excessive back pressure. The DPF has been sized to meet or exceed the EPA service interval regulations.

A trained service technician at a service center will determine if the aftertreatment DPF ash load is excessive and if the filter should be removed from the aftertreatment DPF and replaced. If the aftertreatment DPF ash load is below the removal level, the service technician can run a manual stationary aftertreatment DPF regeneration using Tech Tool.

The aftertreatment diesel oxidation catalyst (DOC) is not serviceable.

Aftertreatment Diesel Particulate Filter (DPF)

The aftertreatment DPF with diesel oxidation catalyst (DOC) and particulate trap reduces the emission of particulates (soot), hydrocarbons (HC) and carbon monoxide (CO).

Only Ultra Low Sulphur Diesel with a sulphur limit of 15 parts per million may be used to prevent clogging the aftertreatment DPF. **The maximum allowable blend of biodiesel is 5%.**

In the aftertreatment DPF system, soot is trapped in a catalyzed ceramic monolith particulate filter with noble metal coating. The aftertreatment DPF is regenerated passively or actively by an aftertreatment hydrocarbon doser that injects diesel fuel to burn the exhaust gases by catalytic reaction. This reduces the amount of soot and extends the life of the aftertreatment DPF.

The aftertreatment DPF system is designed to primarily use passive aftertreatment DPF regeneration, which removes soot from the monolith by a catalytic reaction process that does not use additional fuel.

If the duty cycle is more “stop-and-go”, passive aftertreatment DPF regeneration might be insufficient to remove soot. Then a forced stationary regeneration will be necessary.

In some applications, to increase the exhaust gas temperature (EGT) and maintain it during the heat mode required by forced stationary regeneration, an engine turbocharger compressor bypass valve is connected to the compressor side of the engine turbocharger. It recirculates part of the warm charge air from the outlet to the inlet of the engine turbocharger. A solenoid valve turns the bypass valve on or off.

The compact DPF is mounted on the frame behind the right front wheel. The vertical back of cab (VBOC) DPF is mounted behind the cab.

There are two NOx sensors used with US2010 emissions engines. One is mounted on the DPF outlet pipe and the other is mounted on the pipe after the selective catalytic reduction (SCR) unit. Refer to the aftertreatment SCR system section of this bulletin for more details about SCR.

The aftertreatment DPF continuously oxidizes particles trapped in it. Some of the particles trapped in the aftertreatment DPF are inorganic material (ash) that can't be oxidized. The aftertreatment DPF must be serviced, because the ash will eventually build up, block the filter, and create exhaust gas back pressure. This increases fuel consumption and can cause derate, excessive engine wear or damage, and aftertreatment DPF damage.



W2054096

DPF, Compact

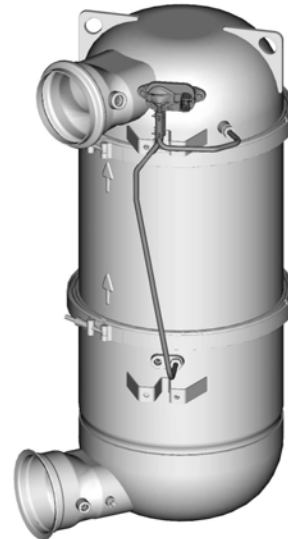

W2058170

DPF, VBOC

Engine Turbocharger Compressor Bypass Valve

Lower torque levels require more heat for efficient aftertreatment diesel particulate filter (DPF) regeneration. The compact and VBOC DPF systems may have an engine turbocharger compressor bypass valve that can create higher exhaust gas temperatures (EGTs) by reducing engine turbocharger effectiveness. The bypass valve recirculates boosted air back into the engine turbocharger compressor inlet. This raises the EGT and maintains the aftertreatment diesel oxidation catalyst (DOC) temperature at a level that allows DPF regeneration.



W2005903

Aftertreatment Hydrocarbon Dosing System

The aftertreatment hydrocarbon doser injects diesel fuel into the exhaust stream to increase the exhaust gas temperature (EGT) to the range needed for active aftertreatment diesel particulate filter (DPF) regeneration when passive DPF regeneration is insufficient to prevent a high soot level in the filter. The engine control module (ECM) notifies the driver that a forced stationary regeneration is needed so the driver can start it with a switch on the dashboard. A service technician can start it manually in a safe location. The aftertreatment hydrocarbon doser is also used when the engine is moving to heat up the system and quickly get the engine in compliance with US2010 emissions requirements. At idle this is done by adjusting the engine timing and fuel delivery to increase EGT.

Aftertreatment Hydrocarbon Dosing System Components (Previous Version)

US2010 emissions compliant engines with compact and VBOC DPF systems have a continuous air purge system which removes any fuel remaining in the aftertreatment hydrocarbon doser after aftertreatment DPF regeneration. When the engine is operating, there is a constant flow of air through the aftertreatment hydrocarbon doser. The secondary vehicle air system, which is off when the engine is off, supplies the air. The main components of the system are:

- Chassis-mounted pressure regulator with inlet filter
- Aftertreatment Hydrocarbon Doser mounted check valve assembly
- Air and fuel supply tubes and hoses
- Air dryer cartridge with coalescing element
- Air shutoff valve

The secondary air system sends air to the in-line filter mounted on the pressure regulator inlet. The pressure regulator lowers the air pressure from chassis pressure, 620-825 kPa (90-120 psi), to approximately 220 kPa (32 psi). Air from the regulator flows through a one-way check valve with a filter screen, which prevents back-flow to the regulator. Air then flows through the doser and into the engine exhaust stream. Fuel is also sent to the doser check valve through a one-way check valve. The ECM controls air and fuel flow to the aftertreatment hydrocarbon doser. The shutoff valve prevents air leakage into the fuel system when the ignition switch is in the OFF position.

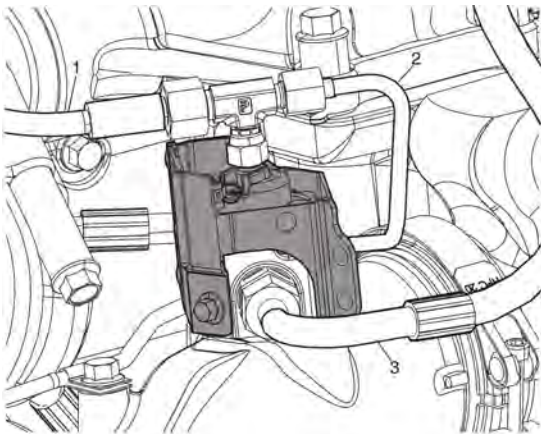

W2006759

- 1 Air Line
- 2 Fuel Line
- 3 Coolant Line

Aftertreatment Hydrocarbon Dosing System Components (New Version)

The main components of the new system are:

- Aftertreatment hydrocarbon dosing module
- Aftertreatment hydrocarbon doser
- Air and fuel supply tubes and hoses
- Chassis-mounted pressure regulator with inlet filter
- Air dryer cartridge with coalescing element

The aftertreatment hydrocarbon dosing module contains three non-serviceable valves, the aftertreatment fuel shutoff valve, aftertreatment purge air valve and aftertreatment hydrocarbon dosing control valve, and a serviceable aftertreatment fuel pressure sensor.

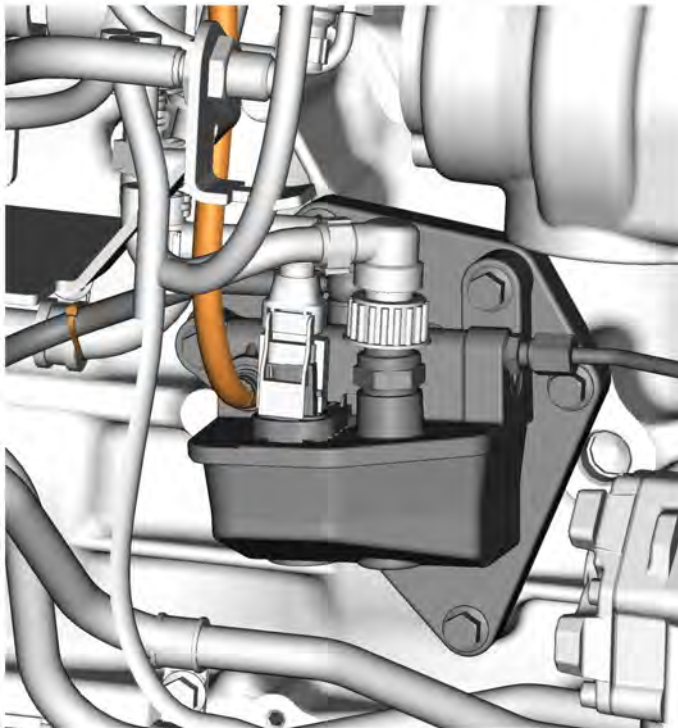

W2064628

Aftertreatment Hydrocarbon Dosing Module

The secondary air system sends air to the in-line filter mounted on the pressure regulator inlet. The pressure regulator lowers the air pressure from chassis pressure, 620–825 kPa (90–120 psi), to approximately 220 kPa (32 psi). During air purge operation, the engine control module (ECM) sends a voltage signal to open the aftertreatment purge air valve. This allows air pressure to flow into the aftertreatment hydrocarbon dosing module. The ECM then sends a signal to the aftertreatment hydrocarbon dosing control valve that allows purge air pressure to be monitored by a signal from the aftertreatment fuel pressure sensor to the ECM. The ECM uses this input to determine if the system is operating correctly.

During aftertreatment DPF regeneration, the ECM sends a voltage signal to open the aftertreatment fuel shutoff valve. This allows fuel to flow into the aftertreatment hydrocarbon dosing module. The aftertreatment fuel pressure sensor monitors the fuel pressure value and sends a reference signal to the ECM. The ECM then sends a signal to the aftertreatment hydrocarbon dosing control valve that regulates the amount of fuel delivered to the aftertreatment hydrocarbon doser through the air/fuel line.

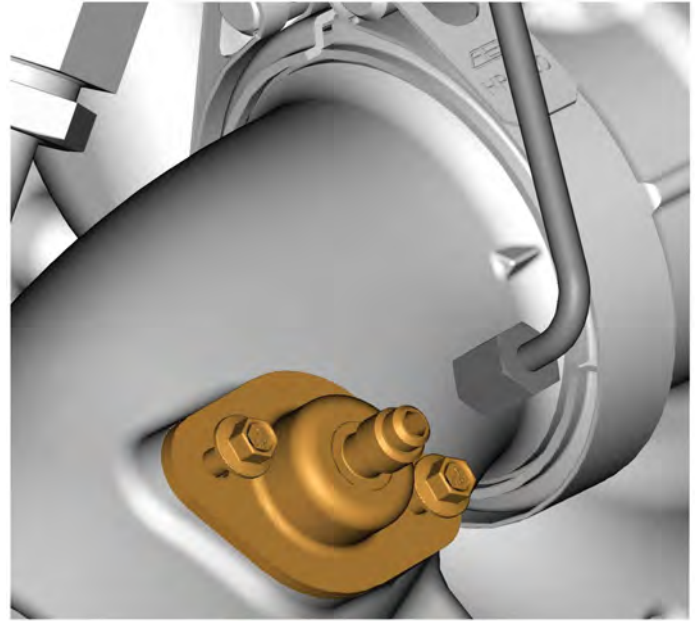

W2064631

Aftertreatment Hydrocarbon Doser

Compact Aftertreatment Diesel Particulate Filter

MACK conventional models equipped with a catalyzed, compact DPF system for US2010.

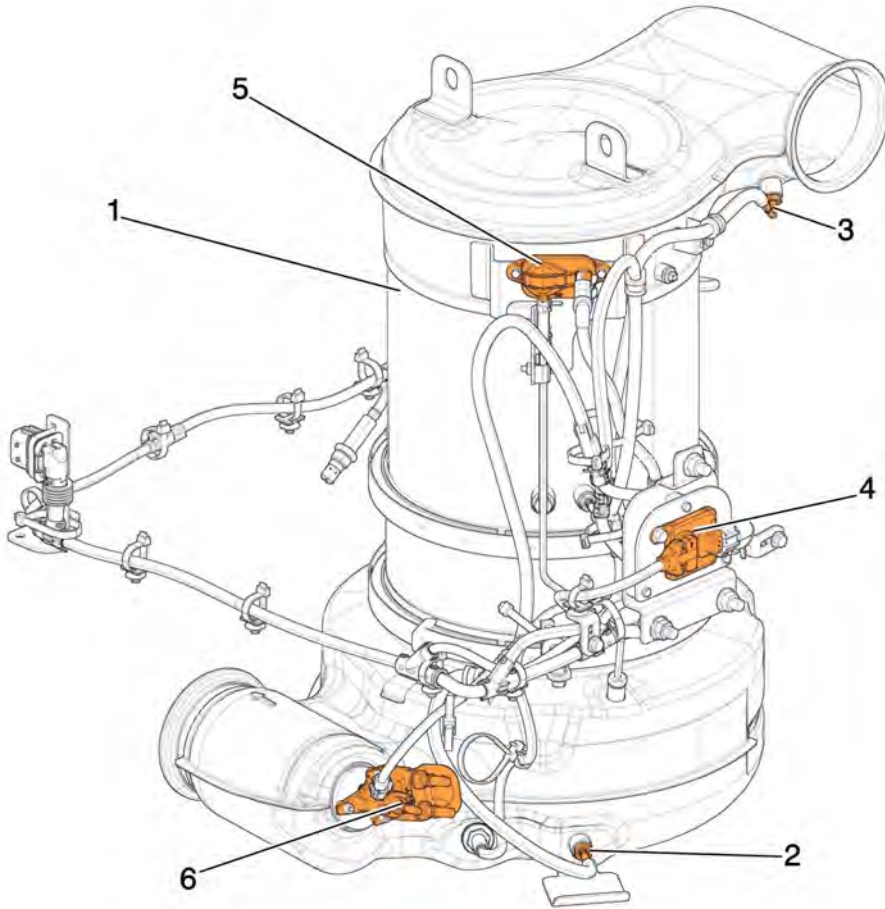

W2076502

Compact

- 1 Aftertreatment Compact DPF
- 2 Aftertreatment Exhaust Gas Temperature (EGT) Sensor
- 3 Aftertreatment DPF Intake Temperature Sensor
- 4 Aftertreatment NOx Sensor
- 5 Aftertreatment DPF Differential Pressure Sensor
- 6 Aftertreatment DEF Doser

Descriptions of the function of each component of the Compact DPF system follow.

- **Aftertreatment Exhaust Gas Temperature (EGT) Sensor.** The sensor measures the EGT as it enters the DPF assembly. The ACM monitors the EGT and starts DPF regeneration when the system has been warmed up for a specified amount of time.
- **Aftertreatment DPF Intake Temperature Sensor.** The sensor measures the EGT at the DPF insert inlet. The ACM monitors the temperature and calculates the amount of fuel the aftertreatment hydrocarbon doser needs to inject into the combustion chamber to meet the required temperature.
- **Aftertreatment DPF Outlet Temperature Sensor.** The sensor measures the EGT at the DPF outlet. The ACM monitors the temperature for system fault detection and SCR operation.
- **Aftertreatment Nitrogen Oxide (NOx) Sensor.** The sensor measures the NOx level in the exhaust gases. If the system does not maintain the required emissions level, a warning light appears on the instrument panel in the cab and a diagnostic trouble code (DTC) is stored in the ECM.
- **Aftertreatment DPF Differential Pressure Sensor.** This sensor gives one of the signals that activates DPF regeneration
- **Aftertreatment DEF Doser**

Aftertreatment Diesel Particulate Filter (DPF), Spark Assisted, Vertical Back of Cab (VBOC) System

MACK model MRU and LEU trucks equipped with the MP7 US2010 engine have a spark assisted, vertical back of cab (VBOC) DPF system. This system is necessary because these truck models (such as refuse collection trucks) are typically driven in a “stop and go” environment. Although some passive regeneration occurs during operation, this type of use can not maintain a high enough temperature for optimum DPF regeneration without assistance.

In the spark assisted VBOC DPF system, compressed air and fuel are combined with exhaust gas in a combustion chamber where electrodes ignite the mixture. This increases the temperature in the DPF filter to a specified temperature that allows oxidation of the PM or soot in the DPF.

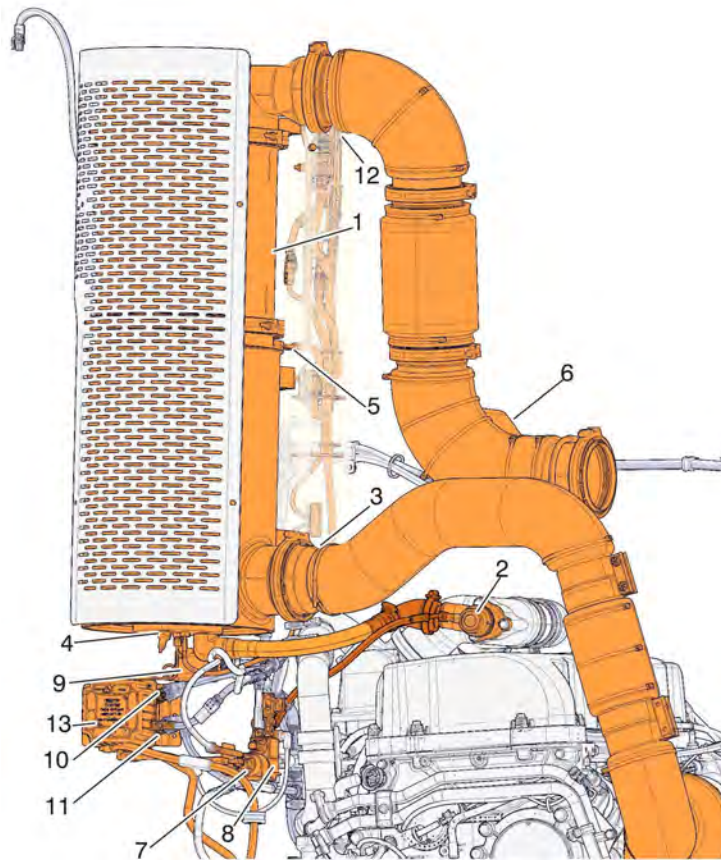

W2061187

Spark Assisted DPF System Components

- | | | |
|--|---|---|
| 1. DPF, Spark Assisted VBOC | 2. DPF Combustion Air Valve | 3. Exhaust Gas Temperature (EGT) Sensor |
| 4. DPF Spark Assisted Flame Temperature Sensor | 5. DPF Intake Temperature Sensor | 6. DPF Outlet Temperature Sensor |
| 7. Aftertreatment Fuel Pump | 8. Aftertreatment Fuel Shutoff Valve | 9. DPF Ignition Coil |
| 10. DPF Air Pressure Sensor | 11. Aftertreatment Fuel Pressure Sensor | 12. DPF Differential Pressure Sensor |
| 13. DPF Atomization Module | | |

Descriptions of the function of each component of the spark assisted VBOC DPF system follow.

- DPF Combustion Air Valve. The valve supplies charged air from the intake manifold to the DPF combustion chamber and is activated by the aftertreatment control module (ACM).
- Exhaust Gas Temperature (EGT) Sensor. The sensor measures the EGT as it enters the DPF assembly. The ACM monitors the EGT and starts DPF regeneration when the system has been warmed up for a specified amount of time.
- Spark Assisted DPF Flame Temperature Sensor. The sensor measures the EGT in the DPF flame region during aftertreatment DPF regeneration. The ACM monitors the temperature to detect the existence of the flame. Diagnostic trouble codes (DTCs) may result if the system can not light the flame or if there are multiple flame losses.
- DPF Intake Temperature Sensor. The sensor measures the EGT at the DPF insert inlet. The ACM monitors the temperature and calculates the amount of fuel the DPF atomization module needs to inject into the combustion chamber to meet the required temperature.
- DPF Outlet Temperature Sensor. The sensor measures the EGT at the DPF outlet. The ACM monitors the temperature for system fault detection and SCR operation.
- Aftertreatment Fuel Pump. The ACM activates the fuel pump and the fuel shutoff valve during active diagnostics and during the DPF regeneration process. Pressurized fuel from the engine fuel system then moves through the fuel shutoff valve to supply the fuel pump. The fuel pump increases the fuel pressure to approximately 689.5 kPa (100 psi) and then moves the pressurized fuel to the DPF atomization module.
- Aftertreatment Fuel Shutoff Valve. The valve is normally closed. The ACM activates the fuel shutoff valve and the fuel pump during active diagnostics and during the DPF regeneration process. When the valve is opened, pressurized fuel from the engine fuel system is sent to the fuel pump and then moved to the DPF atomization module.
- DPF Ignition Coil. The ACM activates the ignition coil with both a positive and a negative pulsed width modulated (PWM) signal. The ignition coil is connected to the ignition electrodes by two ignition wires. When the ACM activates the coil it supplies 40,000 to 45,000 volts to the electrodes, which creates an arc that ignites the atomized fuel and air mixture in the DPF combustion chamber.
- DPF Air Pressure Sensor. The sensor monitors the pressure of the compressed air supplied to the DPF atomization module during active diagnostics and it measures the combined atomization fuel and air pressure during burner operation.
- Aftertreatment Fuel Pressure Sensor. This sensor gives one of the signals that regulates the opening of the fuel shutoff valve and is used to check for faults during active diagnostics.
- DPF Differential Pressure Sensor. This sensor gives one of the signals that activates DPF regeneration
- DPF Atomization Module. The module consists of the DPF air shutoff valve, DPF atomization air valve, DPF fuel control valve, air pressure regulator and fuel pressure regulator. The air shutoff valve is normally closed and opens when the ACM supplies ground to the solenoid. It opens when the engine starts and closes when the engine stops. Compressed air from the air tank is supplied through the priority valve to the air shutoff valve and keeps the DPF fuel nozzle clean during normal operation. The air shutoff valve also helps with fuel atomization during DPF regeneration. The atomization air valve is normally closed and opens when the ACM supplies ground to the solenoid. When the atomization air valve is open, compressed air flows from the air tank through the priority valve, the air shutoff valve and the atomization air valve to the atomization nozzle. The ACM activates the fuel control valve with a pulsed ground, which allows fuel to flow to the fuel nozzle and into the DPF combustion chamber. The air pressure regulator keeps the atomization air at approximately 413.7 kPa (60 psi). The fuel pressure regulator keeps the fuel pressure at approximately 689.5 kPa (100 psi).

Aftertreatment Diesel Particulate Filter (DPF), Catalyzed, Vertical Back of Cab (VBOC) System

MACK model MRU and LEU trucks equipped with the MP7 US2010, EOBDU 13 engine have a catalyzed, vertical back of cab (VBOC) DPF system.

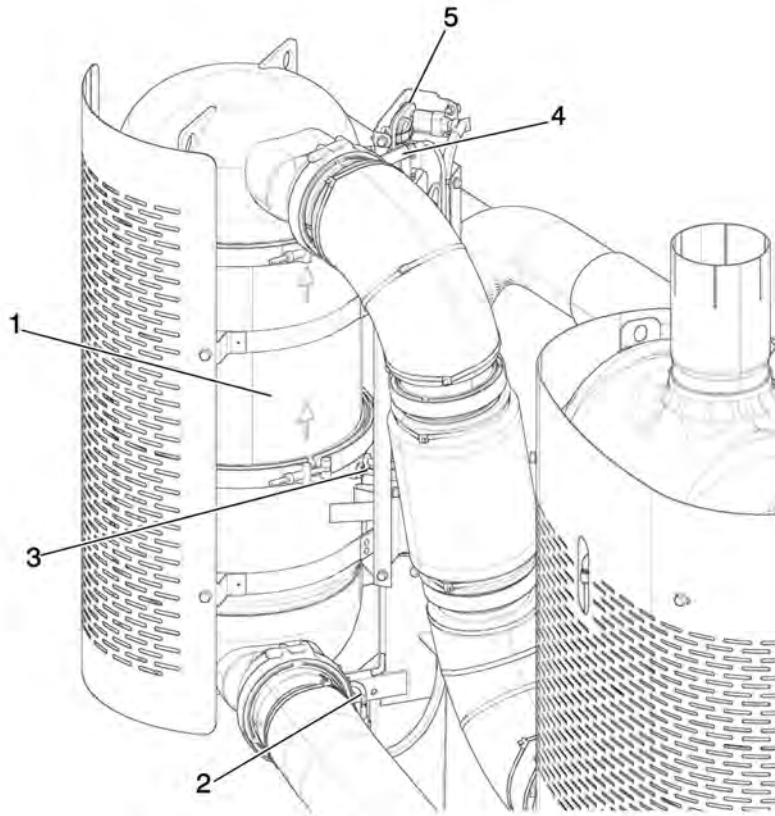

W2076112

- 1 Aftertreatment DPF VBOC
- 2 Aftertreatment Exhaust Gas Temperature (EGT) Sensor
- 3 Aftertreatment DPF Intake Temperature Sensor
- 4 Aftertreatment NOx Sensor
- 5 Aftertreatment DPF Differential Pressure Sensor

Descriptions of the function of each component of the VBOC DPF system follow.

- Aftertreatment Exhaust Gas Temperature (EGT) Sensor. The sensor measures the EGT as it enters the DPF assembly. The ACM monitors the EGT and starts DPF regeneration when the system has been warmed up for a specified amount of time.
- Aftertreatment DPF Intake Temperature Sensor. The sensor measures the EGT at the DPF insert inlet. The ACM monitors the temperature and calculates the amount of fuel the DPF atomization module needs to inject into the combustion chamber to meet the required temperature.
- Aftertreatment DPF Outlet Temperature Sensor. The sensor measures the EGT at the DPF outlet. The ACM monitors the temperature for system fault detection and SCR operation.
- Aftertreatment Nitrogen Oxide (NOx) Sensor. The sensor measures the NOx level in the exhaust gases. If the system does not maintain the required emissions level, a warning light appears on the instrument panel in the cab and a diagnostic trouble code (DTC) is stored in the ECM.
- Aftertreatment DPF Differential Pressure Sensor. This sensor gives one of the signals that activates DPF regeneration

Engine Control Module (ECM)

The engine control module (ECM) controls the aftertreatment systems. The ECM monitors elapsed time, distance travelled, fuel consumption, diesel particulate filter (DPF) soot accumulation, and other sensor signals to determine when conditions are right to start an aftertreatment DPF regeneration.

The ECM also monitors all the valves and components that are required to make sure that aftertreatment DPF

regeneration is controlled and successful. These include, but are not limited to, control of the engine turbocharger compressor bypass valve, the engine turbocharger actuator and the exhaust gas recirculation (EGR) valve position. Control of these and other components is essential for a successful aftertreatment DPF regeneration.

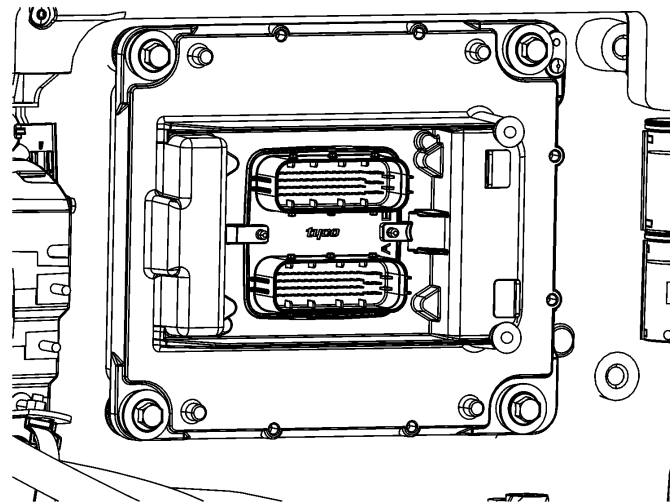

W2059063

Engine Control Module

Emission Control Sensors

The engine control module (ECM), in combination with the aftertreatment control module (ACM), controls the aftertreatment systems by analyzing the data it receives from sensors located throughout the systems. Included are sensors that monitor the engine variable geometry turbocharger (VGT), exhaust gas recirculation (EGR) system, engine

coolant, engine position, aftertreatment diesel particulate filter (DPF) and selective catalytic reduction (SCR). Chassis-mounted sensors are also required, including those that monitor the ambient air temperature (AAT). Examples of some of the main sensors are listed below. Sensors may vary depending on the system used.

Engine Turbocharger

- Turbine Shaft Speed (TSS) Sensor
- Engine VGT Actuator

Engine Position

- Camshaft Position (CMP) Sensor
- Crankshaft Position (CKP) Sensor

Engine Coolant

- Engine Coolant Temperature (ECT) Sensor

Diesel Particulate Filter (DPF), Compact and VBOC

- Engine Exhaust Gas Temperature (EGT) Sensor
- Aftertreatment DPF Intake Temperature Sensor
- Aftertreatment DPF Outlet Temperature Sensor
- Aftertreatment DPF Differential Pressure Sensor
- Aftertreatment Intake NOx Sensor
- Aftertreatment Fuel Pressure Sensor

Diesel Particulate Filter (DPF), Spark Assisted VBOC

- Engine Exhaust Gas Temperature (EGT) Sensor
- Spark Assisted Aftertreatment DPF Flame Temperature Sensor
- Aftertreatment DPF Intake Temperature Sensor
- Aftertreatment DPF Outlet Temperature Sensor
- Aftertreatment DPF Air Pressure Sensor
- Aftertreatment Fuel Pressure Sensor
- Aftertreatment DPF Differential Pressure Sensor

EGR System

- EGR Temperature Sensor
- EGR Differential Pressure Sensor

Intake Air Sensors

- Ambient Air Temperature (AAT) Sensor
- Intake Manifold Air Temperature/Pressure Sensor

Aftertreatment Selective Catalytic Reduction (SCR) System

- Aftertreatment Diesel Exhaust Fluid (DEF) Dosing Pressure Sensor
- Aftertreatment DEF Tank Temperature Sensor
- Aftertreatment DEF Tank Level Sensor
- Aftertreatment Outlet NOx Sensor
- Aftertreatment DEF Quality Sensor

Aftertreatment Selective Catalytic Reduction (SCR) System

US2010 engines use a selective catalytic reduction (SCR) system with aftertreatment diesel exhaust fluid (DEF) dosing to meet US2010 NOx emission regulations, which apply to all heavy duty diesel engines built after January 1, 2010. The new US2010 standards require 83% reduction in nitrogen oxide (NOx) emissions compared to US2007 standards. The aftertreatment SCR system reduces NOx emissions.

The SCR system adds DEF to the exhaust stream. The DEF pump (3) pulls DEF from the DEF tank (2) and sends it to the aftertreatment DEF dosing valve (4). The dosing valve injects DEF into the exhaust gases between the aftertreatment diesel particulate filter (DPF) (5) and the aftertreatment SCR catalyst (6). The treated exhaust then enters the SCR catalyst where the heat in the exhaust system converts the DEF into ammonia and carbon dioxide. Ammonia is the active substance in the chemical reaction in the SCR

catalyst. This chemical reaction occurs at temperatures above 200° C (390° F) and converts nitrogen oxides (NOx) into harmless nitrogen gas and water vapor, which occur naturally in the environment.

The engine control module (ECM) calculates how much and when DEF should be added to the exhaust gases based on the current engine load. The ECM then signals the aftertreatment control module (ACM), which controls the aftertreatment DEF pump and DEF dosing valve. This process maximizes the reduction of emissions during all engine operating conditions.

MACK truck engines are equipped with either a horizontal SCR catalyst or a vertical SCR catalyst. The horizontal SCR system is illustrated.

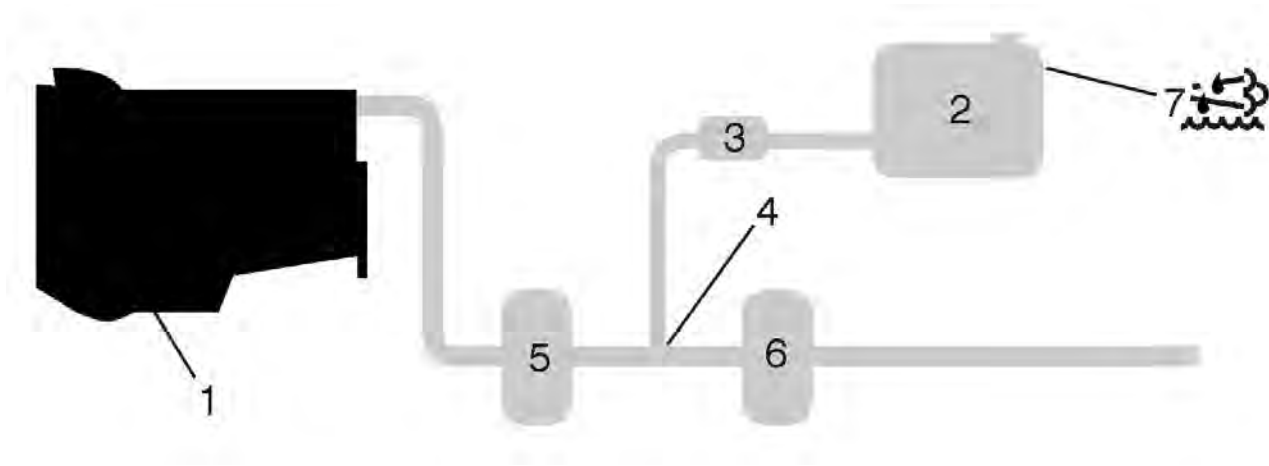

W2031651

- 1 Diesel Engine
- 2 Aftertreatment DEF Tank
- 3 Aftertreatment DEF Pump
- 4 Aftertreatment DEF Dosing Valve
- 5 Aftertreatment DPF
- 6 Aftertreatment SCR Catalyst
- 7 Aftertreatment DEF Tank Gauge

Aftertreatment Selective Catalytic Reduction (SCR) System Components and Function

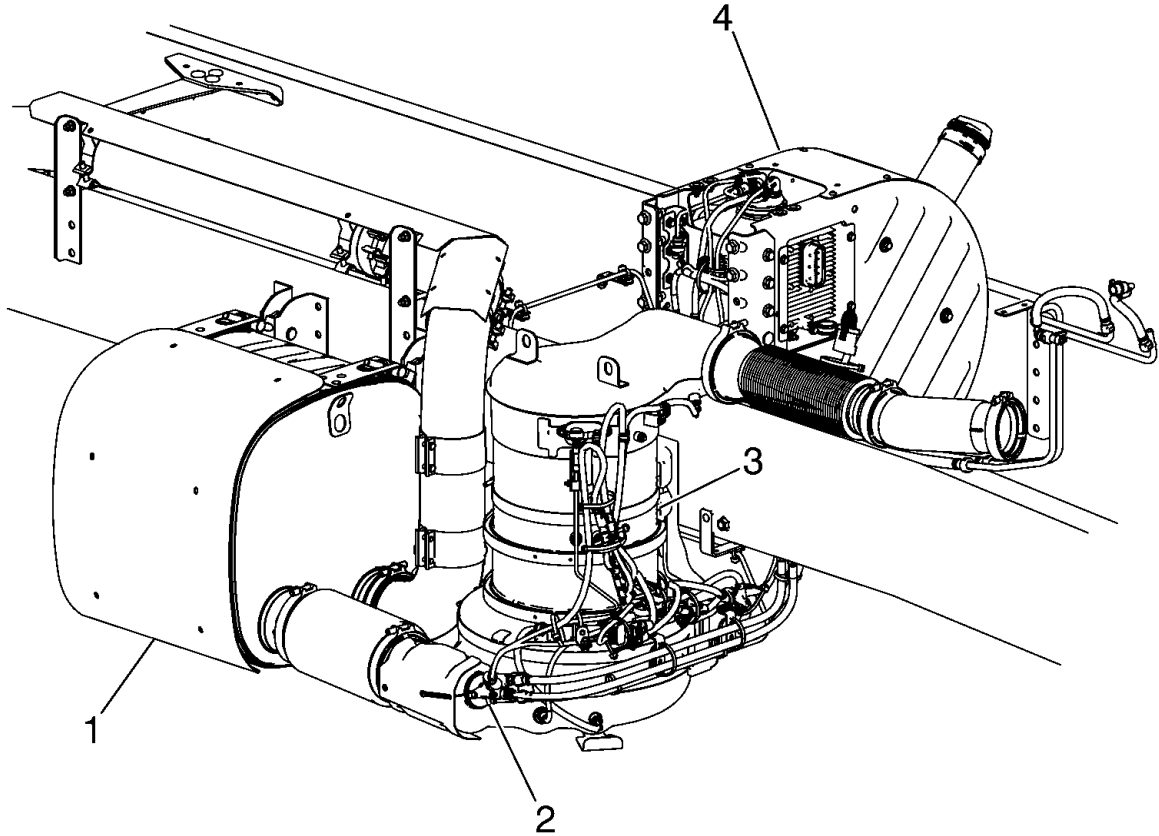

W2029933

- 1 Aftertreatment SCR Catalyst
- 2 Aftertreatment Diesel Exhaust Fluid (DEF) Dosing Valve
- 3 Aftertreatment Diesel Particulate Filter (DPF)
- 4 Aftertreatment DEF Tank

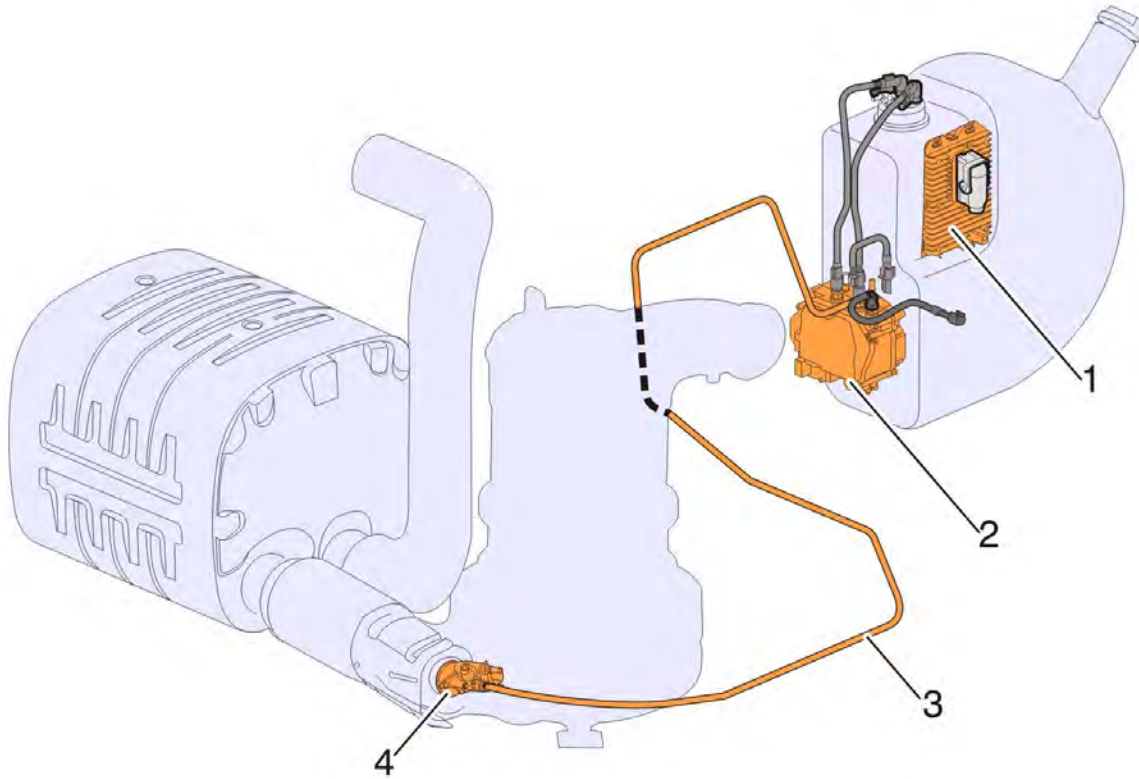

W2038619

- 1 Aftertreatment Control Module (ACM)
- 2 Aftertreatment DEF Pump
- 3 Aftertreatment DEF Line
- 4 Aftertreatment DEF Dosing Valve

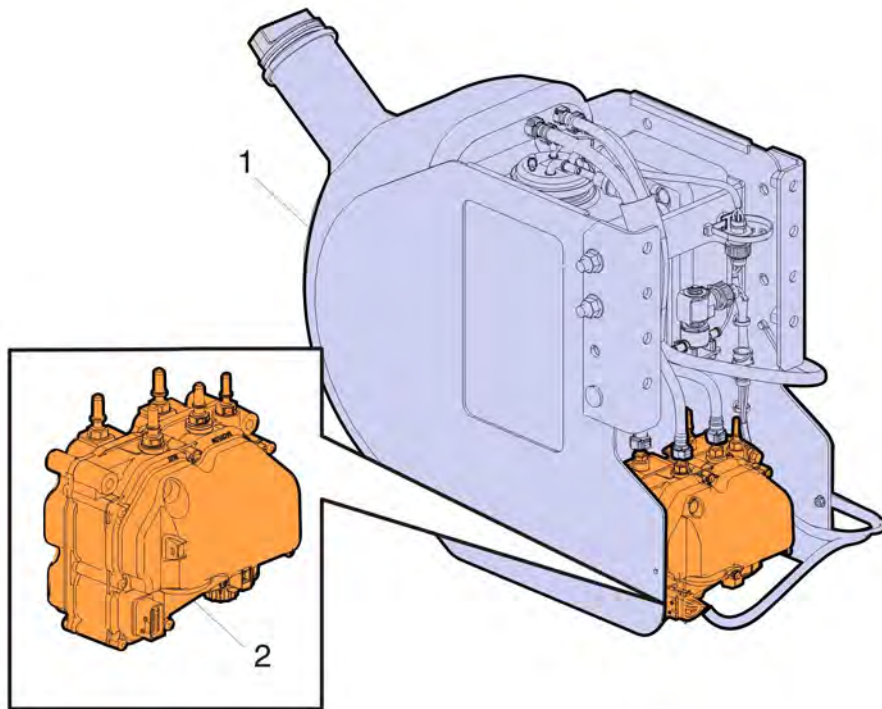

W2038620

- 1 Aftertreatment DEF Tank
- 2 Aftertreatment DEF Pump

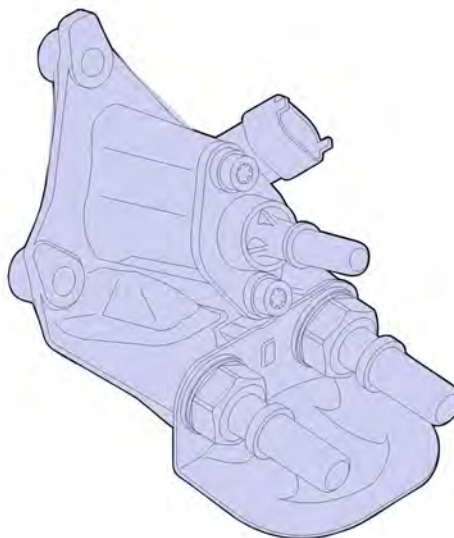

W2038622

Aftertreatment DEF Dosing Valve

The aftertreatment DEF tank level sensor sends a signal to the ACM that tells the ACM that the DEF is above the required minimum level in the DEF tank. The ACM starts the DEF pump, which builds up the system pressure to 900 kPa (130 PSI).

When the SCR system meets certain conditions, the engine control module (ECM) sends a signal to the ACM. The ACM opens the DEF dosing valve, which injects the DEF into the exhaust pipe before the SCR catalyst. The DEF system target pressure of 900 kPa (130 PSI) is maintained by pump motor speed adjustments. A constant overflow of DEF circulates through the backflow orifice to keep the pressure stable.

The high exhaust gas temperature (EGT) converts the DEF into ammonia and carbon dioxide. The ammonia causes a chemical reaction in the SCR catalyst that converts the exhaust gases into nitrogen gas and water vapor.

The nitrogen oxide (NOx) sensor measures the NOx level in the exhaust gases. If the system does not maintain the required emissions level, a warning light appears on the instrument panel in the cab and a diagnostic trouble code (DTC) is stored in the ECM.

The DPF outlet temperature sensor measures the EGT of exhaust gas entering SCR catalyst. The ACM monitors both DPF outlet temperature and NOx sensor signals, calculates the required DEF dosing amount and activates the DEF dosing valve. After the dosing valve is activated, the correct amount of DEF will be injected into the exhaust stream.

The DEF is temperature sensitive. A heating loop in the DEF tank contains hot engine coolant and heats the DEF to thaw it if it is frozen and to prevent it from freezing during engine operation. The tank coolant heating loop also heats the DEF pump. The lines to and from the DEF tank are electrically heated and insulated.

A temperature sensor in the DEF tank continuously monitors the temperature in the tank. If the temperature falls below 10° C (50° F), the ACM opens a DEF tank heating valve which allows hot engine coolant to pass through the DEF tank heating loop and the DEF pump. When the DEF reaches a temperature of 15° C (60° F), the DEF tank temperature sensor signals the ACM which closes the valve and stops the heating. If the ambient air temperature (AAT) drops to 4° C (40° F) or less, the DEF line heaters turn on periodically to keep the lines from freezing.

If the system detects a fault that affects the DEF injection process, a warning light appears on the instrument panel in the cab and a diagnostic trouble code (DTC) is stored in the ECM.

A gauge on the instrument panel in the cab shows the level of DEF in the tank. When the DEF level in the DEF tank gets low, an aftertreatment DEF tank low level indicator appears. See "Aftertreatment DEF Tank Level - Driver Warning &

Inducement", page 27 for more information about low DEF level.

When the engine is shut down, DEF is partly purged from the DEF system. The purging is started by the activation of the aftertreatment DEF return valve and DEF dosing valve and is active for one minute after the engine stops.

Aftertreatment Control Module (ACM)

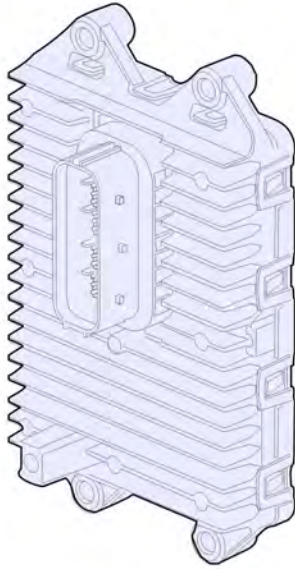

W2038621

The ACM controls the following components in the aftertreatment selective catalytic reduction (SCR) system:

- Aftertreatment Diesel Exhaust Fluid (DEF) Dosing Valve
- Aftertreatment DEF Tank Heater Valve
- Aftertreatment DEF Line Heaters
- Aftertreatment DEF Pump
- Aftertreatment DEF Return Valve
- Aftertreatment DEF Tank Level Sensor

The ACM also monitors the following in the SCR system.

- Aftertreatment DEF Dosing Pressure
- Aftertreatment DEF Tank Temperature
- Aftertreatment DEF Tank Level
- Aftertreatment DPF Intake/Outlet Temperature
- Aftertreatment DPF Differential Pressure
- NOx Sensors

Aftertreatment Diesel Exhaust Fluid (DEF)



WARNING

Do not put diesel fuel in the aftertreatment DEF tank. If diesel fuel is injected into the hot exhaust gases along with the DEF, it could ignite explosively and start a fire, which could cause serious personal injury and damage the exhaust system. The DEF tank filler cap and diesel tank filler cap are labeled and the filler caps, necks and nozzles are different sizes to help prevent the tanks from being filled with the wrong fuel.



WARNING

Aftertreatment DEF is an irritant. Contact with aftertreatment DEF can irritate the skin and eyes. Inhaling aftertreatment DEF mist can cause lung irritation. Avoid aftertreatment DEF contact with skin and eyes. Avoid breathing mist created by aftertreatment DEF spray.



CAUTION

Only use MACK approved aftertreatment DEF in the aftertreatment selective catalytic reduction (SCR) system. Do not use DEF that is not approved by MACK, because it will damage the aftertreatment system permanently, decrease engine output, possibly damage other engine components and may impact your product warranties.

Aftertreatment DEF is a solution of urea crystals and deionized water. Urea is a nitrogen compound that turns into ammonia and carbon dioxide when it is heated. It is colorless, not flammable and freezes at -11°C (12°F). DEF is not dangerous when handled correctly. However, it is highly corrosive to metal, particularly copper and aluminum. See "Aftertreatment DEF Quality - Driver Warning & Inducement", page 28 for more information about DEF quality.

Handling Aftertreatment DEF

 **CAUTION**

When disconnecting lines and components, do not spill aftertreatment DEF onto separated connectors. If this occurs, replace the connectors immediately. Cleaning with water or compressed air will not help as the aftertreatment DEF quickly oxidizes metal and due to capillary action “creeps” along cabling at a speed of about 600 mm/hr (24 in/hr).



W2035724

When you handle DEF make sure the electrical connectors are either connected or well wrapped in a protective cover if they are disconnected.



T2025985

Wrap Exposed Connectors

When You Replace A DEF Pump Or DEF Dosing Valve:

- Make sure the system is depressurized.
- Always detach the aftertreatment DEF lines **before** you disconnect the electrical connectors to prevent DEF spillage from entering the connectors.
- Make sure you wrap exposed connectors in a protective cover.
- Make sure you seal the system so the DEF will not crystallize if the system has to be disconnected for several hours. Part number 21376772 is a set of six cap plugs that can be used to plug the fittings on the DEF pump.

Cleaning Tools And Clothing

 **CAUTION**

Make sure to thoroughly clean aftertreatment DEF off of tools and clothes, so that fluid or crystals do not transfer to other components that could be damaged.

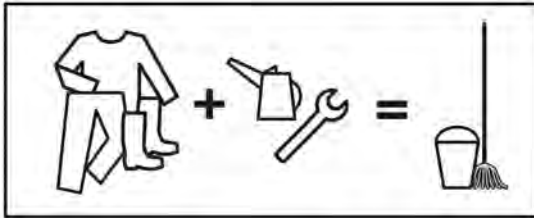

T2023003

DEF Spills

 **WARNING**

Aftertreatment DEF spilled onto hot components will quickly vaporize. Turn your face away to avoid serious personal injury. If you **inhale** DEF vapor, move to a location where you can breathe fresh air. Get medical help, if necessary.

Do not flush DEF spillages into a regular drainage system. Dispose of DEF properly according to local regulations.

If DEF **contacts skin**, remove contaminated clothing and rinse skin with plenty of water.

If DEF **contacts eyes**, rinse eyes for several minutes. Get medical help, if necessary.

Do not allow DEF to come into contact with other chemicals.

DEF is not flammable. If it is exposed to high temperatures, it breaks down into ammonia and carbon dioxide.

DEF is highly corrosive to certain metals, including copper and aluminum.



If DEF spills on the vehicle, wipe it off and rinse with water. Spilled DEF can form white crystals on the vehicle. Rinse them off with water.

Aftertreatment DEF Tank Level - Driver Warning & Inducement





Aftertreatment DEF tanks are sized to have no less than two times the diesel fuel tank mileage or one hour range.

The vehicle instrument cluster has an aftertreatment DEF tank level gauge.

Note: Repeated acts of tampering will result in more severe Inducement.

Triggers	Aftertreatment DEF Tank Low Level Indicator	Driver Information Display Screen
100% to 12 % Aftertreatment DEF Tank Level Gauge	None	None
<=12 % Aftertreatment DEF Tank Level Gauge	 <p>Solid indicator</p>	DEF Tank Level Low Refill DEF Soon to Prevent Engine Derate
0% Aftertreatment DEF Tank Level Gauge (~1% DEF Remaining)	 <p>Blinking indicator</p>	DEF Tank Empty Refill DEF Tank to avoid 5 MPH Limit Engine in Derate
0 % Aftertreatment DEF Tank Level Gauge, Insufficient DEF Pump Pressure, Diesel Fuel Refueling >15%		Refill DEF Tank Vehicle Speed Limited to 5 Mph

Aftertreatment DEF Quality - Driver Warning & Inducement

Triggers	Aftertreatment DEF Quality Indicator	Driver Information Display Screen
Good DEF Quality	None	None
Poor DEF Quality DTC Initial Detected		Poor DEF Quality Detected
Poor DEF Quality DTC Detected		Poor DEF Quality Detected Engine Will Derate in <xxx minutes**
Poor DEF Quality DTC Initial Detected + 1 hours		Poor DEF Quality Detected Engine in Derate5 Mph Limit in <xxx minutes**
Poor DEF Quality DTC Initial Detected + 4 hours of engine operation with active fault.		Service DEF 5 Mph Limit Next Vehicle Stop
Diesel Fuel Tank Level increase by 15% (heavy inducement) with active fault. Also, the vehicle is stationary for 20 minutes at zero vehicle speed.		Service DEF Veh Speed Limited to 5 Mph

Note: ** Once this DEF Quality fault occurs the DID timer displays. The timer can be cleared using the **Enter** (↵) button on the stalk switch.





Exit conditions for DEF Quality "8 km/h (5 mph) road speed limit" Inducement:

Next 1 Engine Starts: Return to 25% torque reduction until there is a proper DEF quality evaluation. If poor DEF quality is detected during the next monitoring cycle then 8 km/h (5 mph) is resumed after the vehicle is stationary for 20 minutes. After one engine start has been exhausted then a Tech Tool is required to exit the 8 km/h (5 mph) road speed limit.

With Tech Tool DTC Clearing: Invoke 25% torque reduction until there is a proper DEF quality evaluation. If poor DEF Quality is detected during the next monitoring cycle then 8 km/h (5 mph) is resumed after the vehicle is stationary for 20 minutes.

Aftertreatment Tampering - Driver Warning & Inducement

When the SCR tampering fault is active for one or more hours a new Driver Information Display screen appears. The text changes for the Driver Information Display (DID) screen associated with this fault are listed in the table below.

Triggers	Aftertreatment Tampering Indicator	Driver Information Display Screen
No Fault	None	None
Tampering Fault Detected Note: For examples of the various SCR sensor tampering types refer to the "SCR Sensor Disconnected Tampering Type" table below.		SCR System Fault Engine Will Derate in <xxx mins
Driving with Active Fault for + 1 hrs		SCR System Fault Engine In Derate 5 Mph Limit in <xxx minutes
Driving with Active Fault for + 4 hrs		SCR System Fault Repair needed 5 Mph limit next Vehicle Stop
Diesel Fuel Tank Level Increase > 15% with active fault		SCR System Fault Veh Speed Limited to 5 Mph

Note: Once this SCR tampering fault occurs, the DID timer is displayed. The timer displays the minutes available before the 5 mph derate occurs. The timer can be cleared using the Escape (ESC) button on the stalk switch control lever. When the vehicle is restarted after shutdown the remaining minutes before derate occurs will reappear.

SCR Sensor Disconnected Tampering Type
Aftertreatment Control Module (ACM) Disconnected
Aftertreatment NOx Sensor Disconnected
DEF Pump Disconnected
DEF Dosing Valve Disconnected
DEF Tank Level Sensor Disconnected
DEF Supply Line to DEF Pump Disconnected
DEF Return Line Blocked or Plugged

Misfilling Diesel Fuel or Aftertreatment DEF Tanks

Although diesel fuel and Aftertreatment DEF caps are clearly labeled and filler necks and nozzles are different accidents can happen.

Contamination of fluids by- misfilling of diesel fuel or DEF in the wrong tank may result in vehicle malfunction.

Results of Misfilling DEF in Diesel Fuel Tank

- Engine may run poorly or not at all
- Injectors may be damaged
- Exhaust system corrosion may occur between engine turbocharger and Aftertreatment DPF
- On Board Diagnostic (OBD) Diagnostic Trouble Codes (DTC)
- Costly repairs

Results of Misfilling Diesel Fuel in Aftertreatment DEF Tank

- Aftertreatment SCR system may be damaged by diesel fuel
- SCR Catalyst may be damaged by diesel (chemical damage)
- Emissions may be non-compliant
- On Board Diagnostic (OBD) Diagnostic Trouble Codes (DTC)
- Costly repairs