

CHAPTER SIX
COMMERCIAL MOTOR VEHICLES
CHAPTER CONTENT

INSPECTION ITEMS FOR COMMERCIAL MOTOR VEHICLES	<u>06.00.00</u>
EXCEPTIONS TO THE CMV INSPECTION REQUIREMENTS	<u>06.05.00</u>
COMMERCIAL VEHICLE INSPECTION ITEMS	<u>06.10.00</u>
CMV INSPECTION PROCEDURES	<u>06.15.00</u>
Backup Lamps	<u>15.1</u>
Beam Indicator	<u>15.2</u>
Brake System	<u>15.3</u>
Clearance Lamps	<u>15.4</u>
Coupling Devices	<u>15.5</u>
Exhaust System	<u>15.6</u>
Frames	<u>15.7</u>
Fuel System	<u>15.8</u>
Hazard Warning Lamps	<u>15.9</u>
Head Lamps	<u>15.10</u>
Horn	<u>15.11</u>
Identification Lamps	<u>15.12</u>
License Plate Lamp	<u>15.13</u>
Mirrors	<u>15.14</u>
Reflective Sheeting/Reflex Reflectors – Conspicuity System	<u>15.15</u>
Reflectors (Rear/Side)	<u>15.16</u>
Safety Guards or Flaps	<u>15.17</u>
Seat Belts	<u>15.18</u>
Side Marker Lamps	<u>15.19</u>
Steering Mechanism	<u>15.20</u>
Stop Lamps	<u>15.21</u>
Suspension	<u>15.22</u>
Tail Lamps	<u>15.23</u>
Tires	<u>15.24</u>
Turn Signal Lamps	<u>15.25</u>
Vehicle Identification Number (VIN)	<u>15.26</u>
Wheels and Rims	<u>15.27</u>
Window Tinting or Coating	<u>15.28</u>
Windshield	<u>15.29</u>
Windshield Wipers	<u>15.30</u>
EXAMPLES OF DEFECTIVE EQUIPMENT ON COMMERCIAL VEHICLES	<u>06.20.00</u>

CHAPTER SIX COMMERCIAL MOTOR VEHICLES

06.00.00 INSPECTION OF COMMERCIAL MOTOR VEHICLES-APPLICABILITY

1. The term “commercial motor vehicle” means a self-propelled or towed vehicle, other than a farm vehicle with a gross weight, registered weight, or gross weight rating under 48,000 pounds, that is used on a public highway to transport passengers or cargo if:

- a. The vehicle, including a school activity bus as defined in Texas Transportation Code (TRC) Section 541.201, or combination of vehicles has a gross weight, registered weight, or gross weight rating of more than 26,000 pounds; or
- b. The vehicle, including a school activity bus as defined by TRC 541.201, is designed to transport more than 15 passengers, including the driver; or
- c. The vehicle is used to transport hazardous materials in a quantity requiring placarding by a regulation issued under the Hazardous Materials Transportation Act (49 U.S.C. Section 5101 et seq.). Additionally, if an automobile or motorcycle is transporting a hazardous material that requires placarding; these types of vehicles would also be required to have a commercial vehicle inspection.

2. The Commercial Motor Vehicle (CMV) Inspection Program also applies to any:

a. school bus that will operate at a speed of 60 mph outside of an urban district as authorized by TRC 545.352(b)(4)(A).

b. vehicle or combination of vehicles with a gross weight rating of more than 10,000 pounds that is operated in interstate commerce and registered in this state.

3. A commercial motor vehicle that is registered in this state shall be required to pass an annual inspection of all safety equipment required by the Federal Motor Carrier Safety Regulations.

4. A commercial motor vehicle required to be inspected under the Federal Motor Carrier Safety Regulations (FMCSR) is also subject to the regular state inspection requirements set forth in Chapter 4 of the Vehicle Inspection Operations & Training Procedures. The statutory fee may be charged for each commercial inspection. A signed vehicle inspection report will be issued for each passing CMV which will designate the vehicle has met both the FMCSR and state inspection requirements.

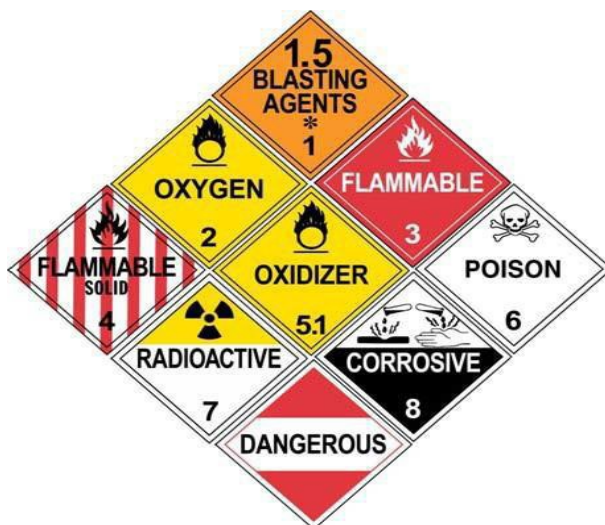

Examples of Hazardous Material Placards

06.05.00 EXCEPTIONS TO THE CMV INSPECTION REQUIREMENTS

1. All school bus operations used to transport only children and/or school personnel from home to school and school to home (contract school buses are not exempt if used for any purpose other than transporting children to and from school).

2. Transportation performed by the Federal Government, State, or any political subdivision of a State, or an agency established under a compact between States that has been approved by the Congress of the United States.

3. The occasional transportation of personal property by individuals not for compensation or in the furtherance of a commercial enterprise.

4. Transportation of human corpses or sick or injured persons.
5. The operation of fire trucks and rescue vehicles while involved in emergency and related operations.
6. The operation of a commercial motor vehicle designed or used to transport between 9 and 15 passengers (including the driver), not for direct compensation, provided the vehicle does not otherwise meet the definition of a commercial motor vehicle.
7. The operation of a commercial motor vehicle designed or used to transport between 9 and 15 passengers (including the driver) for direct compensation, provided the vehicle does not otherwise meet the definition of a commercial vehicle.
8. The following farm vehicles when displaying farm license plates, or when in possession of a State issued Covered Farm Vehicle designation, not transporting hazardous materials requiring placarding, and not operating as a for-hire motor carrier:
 - a. Covered farm vehicles as defined in 49 CFR 390.5. {37 TAC 4.36(g)(7)}.
9. Even if the vehicle is not required to have a CMV Inspection, the vehicle may have to comply with the state inspection requirements set forth in Chapters 4 and 5.

06.10.00 COMMERCIAL VEHICLE INSPECTION ITEMS

A. Check for evidence of financial responsibility. A commercial motor vehicle defined in 06.00.00(1)(a), (b), and (c) is not required to display the standard proof of liability insurance form. The primary method for a commercial motor vehicle to show proof of financial responsibility is found in Annex #1 – Item #8 via cab card or certificate. (Refer to Annex #1).

A commercial motor vehicle not required to register with the Texas Department of Motor Vehicles under Texas Transportation Code, Chapter 643, may display the standard proof of liability insurance form.

B. Licensed dealers of Compressed Natural Gas (CNG), Liquefied Natural Gas (LNG), and Liquefied Petroleum Gas (LPG) are required to collect the per gallon tax when the fuel is sold or delivered into a motor vehicle's fuel supply tank. Vehicles that operate using CNG, LNG, or LPG will no longer prepay the CNG, LNG, or LPG tax by purchasing a decal from the Texas Comptroller's Office. Therefore, a valid liquefied gas tax decal is no longer required to be present before an inspection can be conducted on CNG, LNG, or LPG fueled vehicles.

C. Compressed Natural Gas (CNG) Fuel System

As a pre-requisite to issuing a passing vehicle inspection report, the inspector must verify that a motor vehicle equipped with a CNG Fuel System complies with the requirements of 49 CFR 571.304 and that the expiration date of the fuel container tank has not been exceeded. The inspector can complete this inspection requirement through observation and/or documentation.

The CNG Fuel System inspection should be made immediately after checking for proof of financial responsibility with the owner or operator of the vehicle present.

Observation – Check the label on the CNG fuel container

The CNG fuel container will be located in various places on a CMV. The CNG fuel container is often located in the same position where the standard fuel tanks would be placed. Additionally, the CNG fuel container may be located under the vehicle frame or behind the vehicle cab. On buses, the CNG fuel container is often located under the passenger compartment or on the roof of the passenger compartment.



The CNG fuel container label will be located on the CNG fuel tank.



CNG ONLY



Luxfer Part Number: A2085C-001

Serial Number: ADJ 12345

Service Pressure: 24820 kPa (3600 psig)
at 21°C (70°F)

Date of Manufacture: 7 Δ 2007

DO NOT USE AFTER: 07/2027

Capacity: 200 Liters

Empty Weight: 170 lb.

DOT FMVSS 304 / NGV2-00 / TYPE 3

**FOR USE ONLY WITH THE CONTAINER
MANUFACTURER'S APPROVED PRD
AND VALVES.**

For more information, visit the Luxfer Gas Cylinders website at www.cylindercylinders.com
or call Luxfer customer service at (800) 764-0366. Fax: (951) 781-6598.

WARNING: Improper handling, use, filling, storage or disposal of this container may result in personal injury, death and/or property damage!

WARNING: Do not puncture or drop container. Do not modify container in any way. Never expose container to temperature exceeding 180°F (82°C).

WARNING: This container must be visually inspected after a motor vehicle accident or fire and at least every 36 months or 36,000 miles, whichever comes first for damage and deterioration. For visual inspection after a motor vehicle accident or fire, contact Luxfer Gas Cylinders at (800) 764-0366.

If there is a question about proper use, installation, or maintenance of this container contact Luxfer Gas Cylinders, 3016 Kansas Ave., Riverside, CA 92507; call (800) 764-0366 or fax (951) 781-6598.

Cylinder must be removed from service after the expiration date printed on the standard label.



The inspector should review the label information to determine what the expiration date of the CNG fuel container tank is and if the fuel container tank was manufactured in compliance with 49 CFR 571.304. The expiration date will be shown on the label. The label will also contain “DOT 49 CFR 571.304”, DOT FMVSS 304”, or a similar statement or marking that indicates that the tank was manufactured in accordance with 49 CFR 571.304.

If the CNG fuel tank container label is not readily visible, an alternative location to check for compliance with 49 CFR 571.304 and for the expiration date on the CNG fuel container is on the fuel receptacle lid.



A label will normally be placed on the fuel receptacle lid and will contain both the expiration date for the CNG fuel tank container and information that confirms that the fuel tank container was manufactured in accordance with 49 CFR 571.304. An additional location to check for the CNG fuel tank container expiration date and for compliance with 49 CFR is on a label that may be found in the engine compartment. On certain vehicles, CNG labels may also be affixed to either the driver or passenger door frame or in the glove box area.

Documentation – The vehicle owner or operator may provide documentation from the original equipment manufacturer of the CNG fuel tank container or from a CNG installer or inspector, certified by the Texas Railroad Commission, that the expiration date of the CNG fuel tank container is not expired and the fuel tank container was manufactured in accordance with 49 CFR 571.304. In this situation, the inspector need not visually observe the labels as described above, however, the inspector must retain a copy of the documentation provided in the Vehicle Inspection Station’s files for a period of one year from the date of the inspection.

The vehicle owner or operator may provide documentation that the vehicle is a fleet vehicle and that the fleet operator employs an installer or inspector, certified by the Texas Railroad Commission, for CNG Fuel Systems. In this situation, the inspector need not visually observe the labels as described above, however, the inspector must retain a copy of the documentation provided in the Vehicle Inspection Station’s files for a period of one year from the month of the inspection.

The following is an **example** of the type of information a fleet operator should provide:

October 30, 2015

To Whom It May Concern:

This statement is furnished to comply with the requirements of 37 Texas Administrative Code (TAC) 23.41(e), relating to the inspection of a vehicle equipped with a compressed natural gas (CNG) fuel system. Pursuant to 37 TAC 23.41(e), I hereby certify that this vehicle equipped with a CNG fuel system is a fleet vehicle owned by the Railroad Commission of Texas for which the Railroad Commission of Texas employs a certified installer or inspector of CNG fuel systems as defined in 37 TAC 23.41(g).

CNG Inspection Procedure:

1. Determine by observation if the CNG Fuel Tank Container exceeds the expiration date shown on the container's label or other CNG Fuel System labels attached to the vehicle and if the CNG Fuel Tank Container was manufactured in accordance with 49 CFR 571.304; or
2. Review documentation, provided by the vehicle owner or operator, from the original equipment manufacturer of the CNG Fuel Tank Container or from a Texas Railroad Commission certified CNG installer or inspector that the expiration date of the CNG fuel tank container is not expired and the CNG Fuel Tank Container was manufactured in accordance with 49 CFR 571.304 (retain copy of documentation provided for 1 year in VI Station's files); or
3. If the owner or operator states that the vehicle to be inspected is a fleet vehicle, review documentation provided by the owner or operator that the fleet operator employs a Texas Railroad Commission certified installer or inspector for CNG Fuel Systems (retain copy of documentation provided for 1 year in VI Station's files).

Reject Vehicle if:

1. The CNG Fuel Tank Container was not manufactured in accordance with 49 CFR 571.304.
2. The CNG Fuel Tank Container has exceeded its expiration date.
3. Compliance with 49 CFR 571.304 cannot be determined through observation or documentation.
4. The expiration date of the CNG Fuel Tank Container cannot be determined through observation or documentation.

5. If a fleet operator does not provide documentation that the fleet operator employs a certified installer or inspector for CNG Fuel Systems, unless compliance can be determined by reviewing the CNG labels affixed to the vehicle or from documentation provided by the original equipment manufacturer or from a certified CNG installer or inspector.

A Failing Vehicle Inspection Report is not required to be completed for a vehicle powered by a CNG Fuel System that fails the CNG inspection criteria as this determination should be made immediately after verifying that the vehicle is covered by valid insurance or other financial responsibility documents. If the CNG Fuel System does not pass the inspection, the inspection process shall not proceed any further. The inspector should advise the owner or operator of the vehicle the reason why the CNG Fuel System is failing the inspection.

D. The following is a list of items to be inspected in order to be in compliance with the FMCSR annual inspection.

1. Backup Lamp
2. Beam Indicator
3. Brake System
4. Clearance Lamps
5. Coupling Devices
6. Exhaust System
7. Frames
8. Fuel System
9. Hazard Warning Lamps
10. Head Lamps
11. Horn
12. Identification Lamps
13. License Plate Lamp
14. Mirrors
15. Reflective Sheeting/Reflex Reflectors- Conspicuity System
16. Reflectors (Rear/Side)
17. Safety Guards or Flaps
18. Seat Belts
19. Side Marker Lamps
20. Steering Mechanism

21. Stop Lamps
22. Suspension
23. Tail Lamps
24. Tires
25. Turn Signal lamps
26. Vehicle Identification Number (VIN)
27. Wheels and Rims
28. Window Tinting or Coating
29. Windshield
30. Windshield Wipers

06.15.00 CMV INSPECTION PROCEDURES

A crack in a required lamp is defined as any break, separation, or missing part that permits light from the bulb to emit through the crack or break.

15.1 Backup Lamps

1. Inspect for and reject if (Refer to Annex #3 for lighting diagrams):
 - a. At least one steady burning lamp not present on bus, truck, or truck tractor.
 - b. Not securely mounted or properly located.
 - c. Lamp does not emit proper color (white); lens or bulb painted; or repaired with repair tape or repair kit.
 - d. Lens cracked, broken, discolored, missing, or a portion of the lens is missing.
 - e. Wiring insulation is worn, rubbed bare, or evidence of burning, short circuiting, or poor connection.
 - f. Lamp is not clearly visible in normal sunlight. LED lights have less than 50% of diodes illuminated.
 - g. Lamp not activated properly when bus, truck, or truck tractor is in reverse.
 - h. Lamp assembly is cracked allowing water to enter into the lamp assembly or the lamp assembly contains standing water.

15.2 Beam Indicator

Every new motor vehicle registered in Texas after January 1, 1948, other than a motorcycle or a motor-driven cycle, which has multiple beam road lighting equipment, shall be equipped with a beam indicator (no certain color required) which shall be lighted whenever the uppermost distribution of light from the head lamp is in use, and shall not be otherwise lighted. Said indicator shall be so designed and located that when lighted it will be readily visible without glare to the driver of the vehicle so equipped.

1. Inspection Procedure. Check operation and condition visually.
2. Inspect for and reject if: (When required)
 - a. Vehicle not equipped with a beam indicator.
 - b. Improper switching indication.
 - c. Produces glaring light.
 - d. Inoperative for any reason.

15.3 Brake System

Definitions:

1. Brake System: A combination of one or more brakes and their related means of operation and control.
2. Service Brake System: A brake system used for retarding, stopping, and controlling the vehicle under normal operating conditions. This brake is sometimes referred to as the "foot brake."
3. Parking Brake System: A brake system used to hold and maintain the vehicle in a stationary position. A positive mechanical means is employed to hold the brake applied when the vehicle is unattended.
4. Pedal Reserve: As applied to hydraulic, mechanical, or power assisted hydraulic brakes, this is the amount of distance (total pedal travel) left in reserve when the pedal is depressed to the brake-applied position. The purpose of the pedal reserve check is to ascertain the degree of the brake adjustment and to demonstrate satisfactory brake actuating system condition.

5. Equalization: Brakes shall be so adjusted as to operate as equally as practicable with respect to the wheels on the opposite sides of the vehicle.

6. Driveaway-Towaway Operation: Any operation in which any motor vehicle, trailer, or semitrailer, singly or in combination, new or used, constitutes the commodity being transported when one set or more of wheels of any such vehicle are on the roadway during the course of the transportation, whether or not any such vehicle furnishes the motor power.

Every commercial motor vehicle shall be equipped with brakes acting on all wheels, except trucks and truck-tractors having three or more axles and manufactured without brakes on the front wheels before July 25, 1980.

Any vehicle being towed in a driveaway towaway operation, provided the combination of vehicles is capable of complying with the brake performance requirements, does not require brakes acting on all wheels. House moving dollies that are required to be inspected under the commercial vehicle inspection program are exempt from the braking requirements under the FMCSR and under the special mobile equipment sections of state law. Converter dollies are not exempt from the braking requirements under the FMCSR and special mobile equipment sections of state law.

The service brake test on commercial motor vehicles will be conducted using one of the following methods:

1. On Road (Decelerometer);
2. On Road (Brake Test Area);
3. Platform-Type Tester; or
4. Roller-Type Tester (Dynamometer-Force Measuring Type).

Service Brake Tests

5. On Road (Decelerometer): Mount an approved Decelerometer at centerline of the vehicle. Level the Decelerometer. At a speed of 20 mph apply service brake firmly. Observe Decelerometer reading.

A. Decelerometer Test Procedures:

(1) This tester is an inertia-type Decelerometer consisting of a scale to measure the vehicle's deceleration or equivalent braking force (sometimes referred to as brake efficiency) in percentages. The Decelerometer is generally placed as close to the center of the vehicle as practicable (on window of right front door) and the vehicle is operated on the roadway outside the inspection station.

(2) Operation:

- a. Level Decelerometer and set to "0."
- b. Drive vehicle on a clean, level road (road grade of 5% or less) at 20 mph and apply brakes evenly, without skidding vehicle wheels.
- c. Read the dial to see if vehicle stopped within required stopping distance for class of vehicle.
- d. For brake balance (equalization), the vehicle should stop in a straight line. A pull to side, right or left, during a test stop indicates brake unbalance.

6. Conditions affecting brake tester readings:

- a. Wet tires and roadways may cause readings of braking efficiency to be inaccurate.
- b. Oil slicks, sand, or other foreign material on tires or roadways may also cause readings of braking efficiency to be inaccurate.
- c. Worn or slick tires may also cause readings to be inaccurate.
- d. Any fast, hard application of the brake can cause wheel lockup and tire skid.

2. On Road (Road Test): At a speed of 20 mph apply service brakes firmly. Observe whether a vehicle comes to a smooth stop within the distance prescribed by the chart, "Brake Stopping Distance."

The inspector should have firm control of the steering wheel throughout the test. If a Brake Test Area is used, all vehicles being inspected should be driven at a speed of 20 mph and the vehicle must stop as indicated by the Stopping Distance Chart in Annex #2.

A. If a road test is used for checking service brakes:

- (1) Brake test area must be used on every inspection made.
- (2) When it is raining, snowing, or when the brake surfaces are wet, brake tests are permitted; however, if the certified inspector feels that they cannot safely and with due care accurately check the service brakes, inspector may refuse to perform the inspection.
- (3) No inspections are permitted when the brake test areas are icy.
- (4) Extreme care must be exercised and sudden stops must be avoided if other traffic is affected.
- (5) The brake pedal application must be applied when the vehicle speed reaches 20 miles per hour. The stopping distance is to be measured from the point at which the service brake pedal or control begins. The vehicle must stop within the prescribed stopping distance requirements and must not pull to the right or left. Using the service (foot) brake only, the stopping ability of the vehicle should be tested by actual operation of the vehicle.
- (6) When applying brakes to the moving vehicle, the braking force must be evenly distributed to the wheels. The brakes should be so adjusted as to operate as equally as practicable with respect to the wheels on the opposite sides of the vehicle. The driver should have a firm control of the steering wheel throughout the test.
- (7) Brakes on a truck-tractor may be inspected without a trailer; however, a trailer shall be inspected only with a towing vehicle attached.

3. Platform Tester: Drive vehicle onto "drive-on-and-stop" platform tester consisting of 4 pads or platforms, one for each wheel. Apply brakes firmly at a speed from 4-8 mph without wheel lockup. All braking action must take place on the platforms. Front-wheel drive vehicles are to be checked by road test only unless a platform tester specifically approved by the Department to test front-wheel drive vehicles is used. These machines may be used to inspect the relative effectiveness of each wheel. When the brakes are applied at the time the vehicle is moving on the pads, the braking effort at each wheel causes a proportionate movement of the pad against the measuring system. There should be braking action on all wheels and the action on any one wheel should be 75 percent or more of the action on the other wheel on the same axle.

A. Platform Test Procedures:

- (1) Drive vehicle on brake tester about 5 miles per hour and apply the brakes firmly but not severely. (Excessive speed and braking should be avoided).
- (2) These machines may be used to inspect the relative effectiveness of each wheel. There should be braking action on all wheels, unless otherwise exempt.
- (3) Each gauge will record the individual wheel braking effort in hundreds of pounds.
- (4) Total braking effort and comparative braking energy can be determined.
- (5) The tester must be properly installed, maintained, and kept clean at all times.
- (6) If the vehicle fails the first brake test, a second brake test must be conducted before the vehicle is rejected.

B. Equalization and Tolerances:

- (1) Total reading must not be less than 50% of the total weight of the vehicle if the vehicle has brakes on all wheels. The required 50% is the equivalent of a vehicle stopping within 25 feet at 20 miles per hour.

(2) Total reading must not be less than 35% of the weight of the vehicle if the vehicle does not have brakes on all wheels. The required 35% is the equivalent of a vehicle stopping within 39 feet at 20 miles per hour.

(3) Brake machine readings on each opposing wheel of the same axle shall be within 25% on the front axle and within 35% on the rear axle.

C. Conditions affecting Platform Tester readings:

(1) Wet tires or wet tread plates (pads) will cause readings of braking efficiency to be inaccurate.

(2) Grease, sand, or other foreign material on tires or tread plates (pads) will also cause readings of braking efficiency to be inaccurate.

(3) Worn or slick tires will not affect brake tester as much as they will affect a road test.

(4) Dirt and debris under the tread plates (pads).

4. Roller-Type Brake Dynamometer-Force

(3) Heavy compacts 3,100 to 3,600 pounds - 285 lb Brake Effort/Wheel (Total 570 pounds)

(4) All others over 3,700 pounds - 335 lb Brake Effort/Wheel (Total 670 pounds)

(5) Brake Balance Test - During the "Brake Force Test," variance in braking force between wheels should not exceed 70 pounds.

(E) As an additional service to the vehicle owner or operator, the inspection station is permitted to perform an additional dynamic brake inspection according to recommendations of the equipment manufacturer. However, rejection must be based on the above parameters under "Operation - Acceptance Tests."

(F) If substandard brake conditions are found that are not exposed by the above acceptance test, the inspection station may suggest that brake repairs be made but must clearly inform the vehicle owner or operator that such repairs are not mandatory to pass inspection.

Measuring Type): This type brake tester is equipped with powered rollers that rotate the wheels at a speed of approximately 35 to 45 miles per hour with the vehicle in a stationary position. The brakes are applied while the wheels are turning. Measurements of both **BRAKING FORCE** (Brake Effort) and **BRAKE BALANCE** are indicated on the gauge(s). Brake fade can also be tested on this machine.

(A) Adjust tire inflation to recommended values.

(B) Position vehicle on dynamometer rolls and begin test.

(C) Follow Department's recommended testing procedures as follows.

(D) Operation - Acceptance Tests. With tester in operation and wheels turning, apply brakes slowly until brake effort reaches the following values and hold for 5-6 seconds:

(1) Small vehicle up to 2,200 pounds - 175 lb Brake Effort/Wheel (Total 350 pounds)

(2) Light compacts 2,300 to 3,000 pounds - 230 lb Brake Effort/Wheel (Total 460 pounds)

5. Test Brake Hydraulic System for Leakage

While the vehicle is stopped, the inspector should be able to apply a moderate foot force (40 – 60 pounds in non-power assisted systems or 15 – 20 pounds in power assisted systems).

6. Test Pedal Reserve

While the vehicle is stopped, the inspector should depress the brake pedal under moderate foot force (40 – 60 pounds in non-power assisted systems or 15 – 20 pounds in power assisted systems).

7. Check Condition of Vacuum System

(A) Inspection Procedures:

(1) Visually inspect the vacuum system for collapsed, broken, badly chafed, and improperly supported hoses and tubes. Check for loose or broken hose clamps.

(2) When checking the operation of the vacuum system on a truck or truck-tractor, the trailer shutoff valves must be closed. When checking the operation of the vacuum system on a trailer or semitrailer, the trailer must be coupled to a truck or a truck-tractor with the trailer shutoff valve open. The engine of the truck-tractor should be allowed to run for one minute to build up vacuum.

(3) Visually inspect system for collapsed, broken, badly chafed, and improperly supported hoses and tubes, and loose or broken hose clamps.

(4) On truck or truck-tractor, depress brake pedal with moderate foot force. While maintaining this force on the pedal, start engine, and observe if pedal falls slightly when engine starts.

(5) On trucks with low vacuum indicators build full vacuum. Shut off engine and reduce vacuum by making a series of moderate brake applications. A flashing or buzzing signal shall function when vacuum reaches eight inches mercury.

(6) Apply and release pedal a number of times and observe action on brake chamber rod on trailers.

c. Inspect for and reject if:

a. Brake System does not meet the requirements for stopping distance for the class of vehicle; the service brakes do not develop the required total braking force as determined by machine tests; or the service brakes are not equalized as determined from road or machine testing of the vehicle.

b. Absence of braking action, on any axle required to have brakes, upon application of the service brakes (such as missing brakes or brake shoe(s) failing to move upon application of a wedge, S-cam, cam, or disc brake).

c. Missing or broken mechanical components including: shoes, linings, pads, springs, anchor pins, spiders, cam rollers, push rods, and air chamber mounting bolts.

See the Brake System Diagrams to Assist with Identifying the Component Parts of CMV Brake Systems:

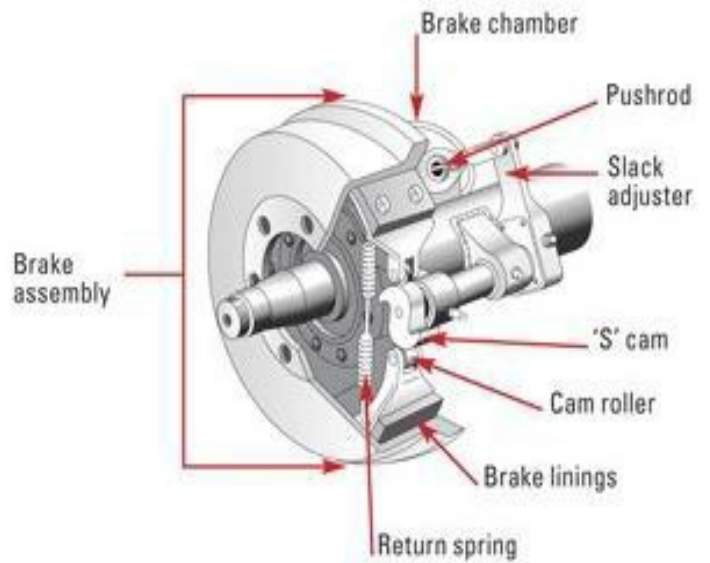

THE "S" CAM BRAKE

Uses an "S" shaped cam to expand the brake shoes against the drum.

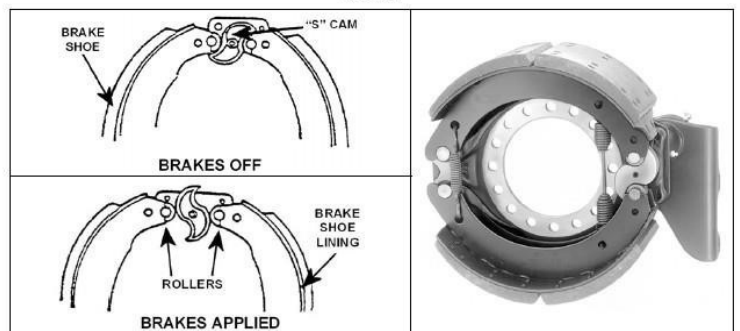
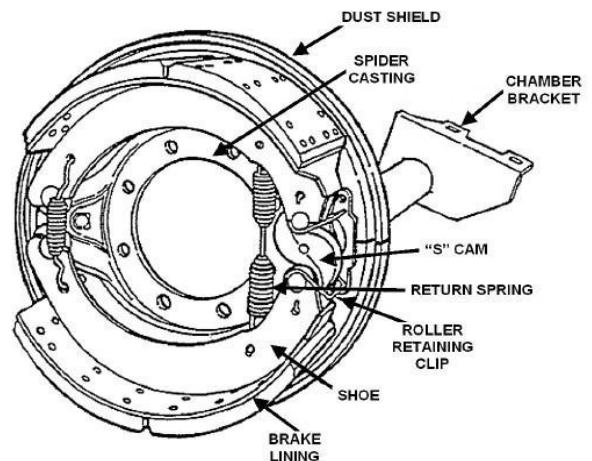

THE DISC BRAKE

Uses two (2) brake pads pinched against a rotating disc or rotor.

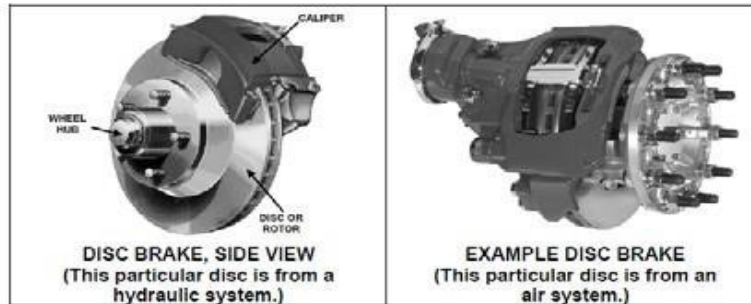
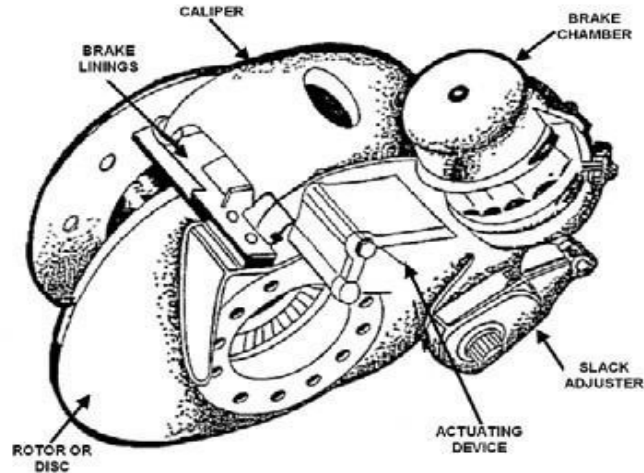

THE WEDGE BRAKE

Uses a wedge forced between two (2) brake shoes to expand the shoes against the drum.

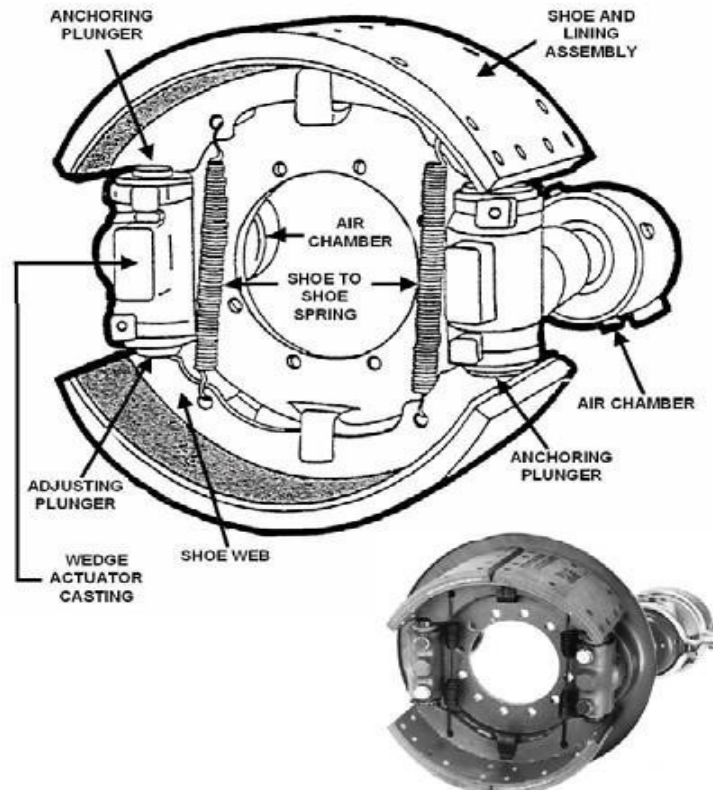

- d. Loose brake components including air chambers, spiders, and cam shaft support brackets.
- e. Audible air leak at brake chamber (e.g., ruptured diaphragm, loose chamber clamp, etc.).
- f. Readjustment limits. Any brake beyond the readjustment limit shall be cause for rejection. Stroke shall be measured with the engine off and an air pressure reservoir of 80 to 90 psi. (Refer to Annex #2 for readjustment limits)

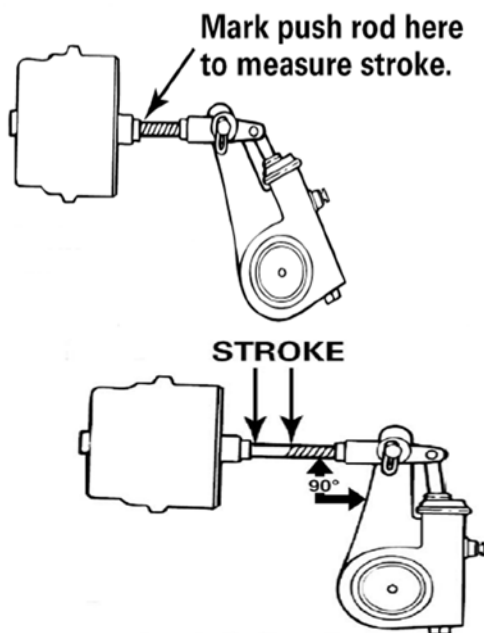

- g. Brake linings or pads:
 - 1) Lining or pad is not firmly attached to the shoe.
 - 2) Saturated with oil, grease, or brake fluid.
 - 3) Non-steering axles: Lining with a thickness less than 1/4 inch at the shoe center for air drum brakes, 1/16 inch or less at the shoe center for hydraulic disc and electric drum brakes, and less than 1/8 inch for air disc brakes.

- 4) Steering axles: Lining with a thickness less than 1/4 inch at the shoe center for air drum brakes, 1/16 inch or less for hydraulic disc and electric drum brakes, and less than 1/8 inch for air disc brakes.
- h. Missing brake on an axle required to have brakes.
- i. Mismatch across any power unit steering axle of:
 - 1) Air chamber sizes.
 - 2) Slack adjuster length.

j. Parking Brake System - The parking brake system shall be adequate to hold the vehicle or combination on any grade upon which it is operated under any condition of loading, on a surface free from ice and snow. The parking brake system shall be capable of being applied by the driver's muscular effort or by spring action. The parking brake system may be assisted by the service brakes or other source of power, provided that failure of the service brakes or other power assisting mechanisms will not prevent the parking brake system from being applied. The parking brake system shall be so designed that when applied, it shall remain in the applied position despite exhaustion of any source of energy or leakage of any kind. If the means of applying the parking brake and the service brake are connected in any way, they shall be so constructed that failure of any one part shall not leave the vehicle without operative brakes. Brake lock systems will not meet the parking brake requirement (i.e. placing the transmission in park).

- 1. Inspection Procedure. Apply only the parking brake system. Verify that brakes are applied on the vehicle or combination upon actuation of the parking brake control.
- 2. Inspect Parking Brake for and reject if:
 - a. Vehicle is not equipped with a parking brake.
 - b. Operating mechanism, when fully applied, does not hold the brakes in applied position without manual effort.

- c. Actuating mechanism is not fully released when the release control is operated.
- d. Any mechanical parts are missing, broken, badly worn, or not operating properly.
- e. Pull cables are badly worn, stretched, frayed, or not operating freely.
- f. Parking brake will not hold the vehicle in place when, with the engine running, the vehicle is placed in forward gear and the engine is accelerated enough to cause a pull on the braking mechanism.



k. Brake Drums or Rotors

Inspect Brake Drum or Rotors and reject if:

- 1) Any external crack or cracks that open upon brake application (do not confuse short hairline heat related cracks with flexural cracks).
- 2) Any portion of the drum or rotor is missing or in danger of falling away.



l. Brake Hose

Inspect Brake Hose and reject if:

- 1) Hose with any damage extending through the outer reinforcement ply. (Rubber impregnated fabric cover is not a reinforcement ply. Thermoplastic nylon may have braid reinforcement or color difference between cover and inner tube. Exposure of second color is cause for rejection).

- 2) Bulge or swelling when air pressure is applied.
- 3) Any audible leaks.
- 4) Two hoses improperly joined (such as a splice made by sliding the hose ends over a piece of tubing and clamping the hose to the tube).
- 5) Air hose cracked, broken, or crimped.

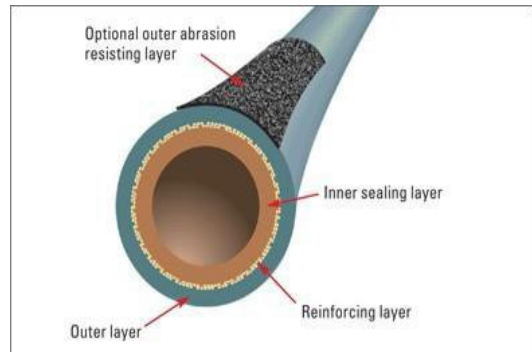

m. Brake Tubing

Inspect Brake Tubing and reject if:

- 1) Any audible leak.
- 2) Tubing cracked, damaged by heat, broken, or crimped.

n. Low Pressure Warning Device. Before March 1, 1975, vehicles may have either an audible or visible warning device. On or after March 1, 1975 vehicles must have a visible device and may also have an audible warning. Gauges alone are not acceptable as warning devices.

Inspect Low Pressure Warning Device and reject if:

- 1) Missing, inoperative, or does not operate at 55 psi and below, or 1/2 the governor cut-out pressure, whichever is less.

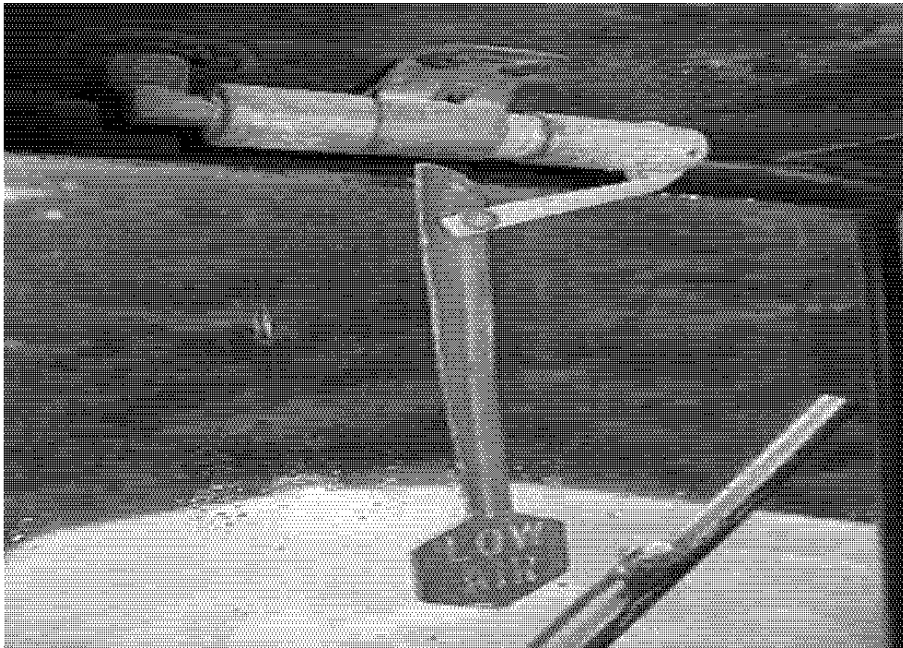
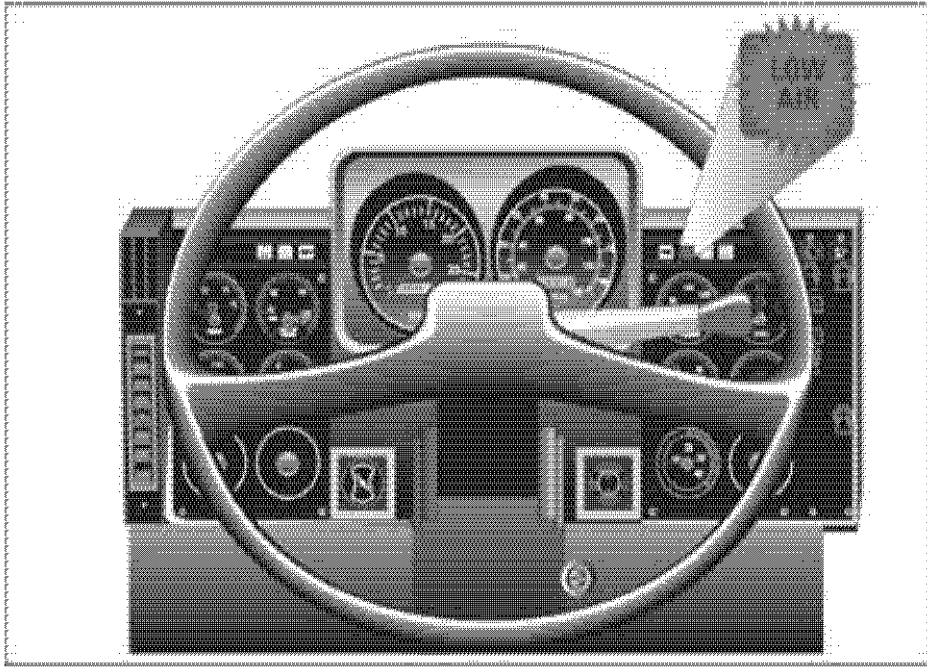

o. Tractor Protection Valve

Inspect Tractor Protection Valve and reject if:

- 1) Inoperable or missing tractor protection valve(s) on power unit.

p. Air Compressor/Air Reservoir System

Inspect Air Compressor/Air Reservoir System and reject if:

- 1) Compressor drive belts in condition of impending or probable failure.
- 2) Loose compressor mounting bolts.
- 3) Cracked, broken, or loose pulley.
- 4) Cracked or broken mounting brackets, braces, or adaptors.
- 5) Compressor air intake cleaner is clogged sufficiently to prevent the proper intake of air.
- 6) Time required building up air pressure from 50 to 90 psi takes more than 3 minutes with the engine running a fast idle.
- 7) Compressed air reservoir is insufficient to permit one full service brake application with the engine stopped, and with the system fully charged, without lowering the reservoir pressure more than 20% below the initial air pressure reading.
- 8) Governor cut-in pressure lower than 80 psi or cut-out pressure higher than 135 psi, unless other values are recommended by the vehicle manufacturer.
- 9) Air reservoir pressure drop of more than 2 psi in 1 minute for a single vehicle or more than 3 psi in 1 minute for vehicle combinations with the engine stopped and the service brake released.
- 10) Air reservoir pressure drop of more than 3 psi in 1 minute for a single vehicle or more than 4 psi in 1 minute for vehicle combinations with the engine stopped and the service brakes fully applied.

q. Electric Brakes

Inspect Electric Brakes and reject if:

- 1) Absences of braking action on any wheel required to have brakes.
- 2) Missing or inoperable breakaway braking device.

r. Hydraulic Brakes. (Including Power Assist Over Hydraulic and Engine Drive Hydraulic Booster)

Inspect Hydraulic Brakes and reject if:

- 1) Master cylinder less than ¼ full.
- 2) No pedal reserve with the engine running except by pumping pedal.
- 3) Power assist unit fails to operate.
- 4) Seeping or swelling brake hose(s) under application of pressure.
- 5) Missing or inoperative check valve.
- 6) Has any visually observed leaking hydraulic fluid in the brake system.
- 7) Has hydraulic hose(s) abraded (chafed) through the outer cover-to-fabric layer.
- 8) Fluid lines or connections leaking, restricted, crimped, cracked, or broken.
- 9) Brake failure or low fluid warning light on or inoperative.

s. Vacuum Systems

Inspect Vacuum Brakes and reject if:

- 1) Has insufficient vacuum reserve to permit one full brake application after the engine is shut off.
- 2) Has vacuum hose(s) or line(s) restricted, abraded (chafed) through outer cover to cord ply, crimped, cracked, broken, leaking or has collapse of vacuum hose(s) when vacuum is applied.
- 3) Lacks an operative low-vacuum warning device as required.

15.4 ClearanceLamps

Clearance lamps are required on all:

- 1) Buses 80 inches or more in overall width.
- 2) Trucks 80 inches or more in overall width.
- 3) Trailers and semitrailers 80 inches or more in overall width.
- 4) Trailers and semitrailers 30 feet or more in overall length.
- 5) Poletrailers.

Clearance lamps shall, so far as is practicable, be mounted on the permanent structure of the vehicle in such a manner as to indicate the extreme height and width of the vehicle. Mounting exceptions for clearance lamps are as follows:

- 1) On a truck tractor, clearance lamps mounted on the cab may be located to indicate the width of the cab, rather than the width of the vehicle.
- 2) On a trailer, the front clearance lamps may be mounted at a height below the extreme height if mounting at the extreme height results in the lamps failing to mark the overall width of the trailer.
- 3) When the rear identification lamps are mounted at the extreme height of a vehicle, rear clearance lamps are not required to be located as close as practicable to the top of the vehicle.

Clearance lamps and side marker lamps may be mounted in combinations, provided illumination is given as required by law.

Clearance lamps mounted on the front or on the sides near the front of a vehicle shall display an amber color.

Clearance lamps mounted on the rear or on the sides near the rear of a vehicle shall display a red color.

Clearance lamps shall be visible under normal atmospheric conditions at a distance between 500 feet and 50 feet from the vehicle on which mounted.

On buses and trucks 80 inches or more in overall width and trailers and semitrailers 80 inches or more in overall width:

- 1) On the front, two clearance lamps.
- 2) On the rear, two clearance lamps.

1. Inspection Procedures (Refer to Annex #3 for lighting diagrams):

- a. Check operation and condition visually.

2. Inspect for and reject if:

- a. Lamps are not present.
- b. Lamps are not securely mounted, properly located, or repaired with repair tape or repair kit.
- c. Lamps do not emit required color; lens or bulb painted; or not steady burning.
- d. Visibility requirements are not met. LED lights have less than 50% of diodes illuminated.
- e. Lens is discolored, missing, or a portion of the lens is missing.
- f. Wiring insulation is worn, rubbed bare, or shows any evidence of burning, short circuiting, or poor electrical connections.
- g. Lens is cracked.
- h. Any lamp assembly is cracked allowing water to enter or the lamp assembly contains standing water.

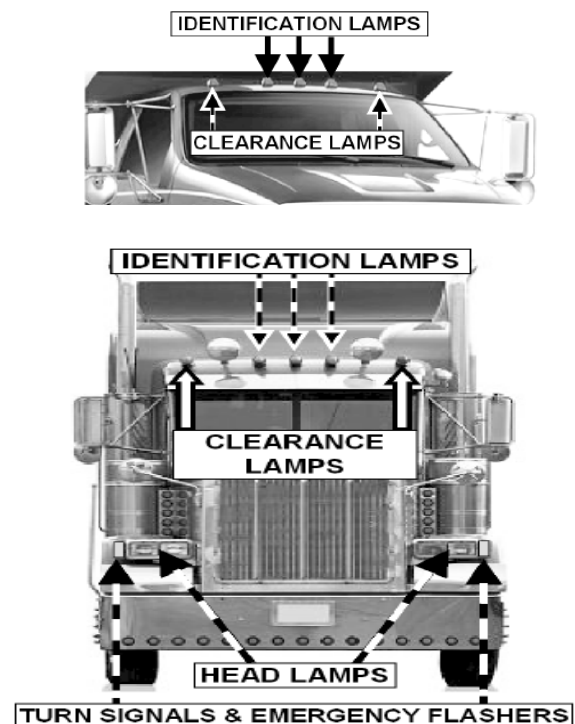

15.5 Coupling Devices

A. Inspect Fifth Wheel for and reject if:

- 1) Mounting to Frame:
 - a. Any fasteners missing or ineffective.
 - b. Any movement between mounting components.
 - c. Any mounting angle iron cracked or broken.
- 2) Mounting Plates and Pivot Brackets:
 - a. Any fasteners missing or ineffective.
 - b. Any welds or parent metal cracked.
 - c. More than 3/8 inch horizontal movement between pivot bracket pin and bracket.
 - d. Pivot bracket pin missing or not secured.
- 3) Sliders:
 - a. Any latching fasteners missing or ineffective.
 - b. Any fore or aft stop missing or not securely attached.
 - c. Movement more than 3/8 inch between slider bracket and slider base.
 - d. Any slider component cracked in parent metal or weld.

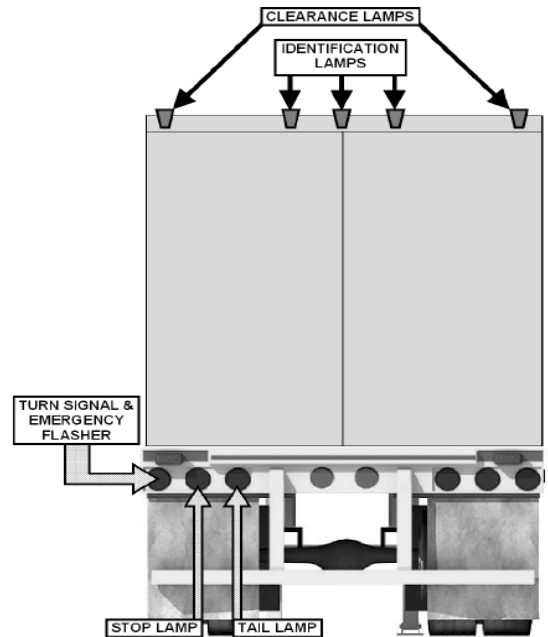

1) Lower Coupler:

- a. Horizontal movement between the upper and lower fifth wheel halves exceeds ½ inch.
- b. Operating handle not in closed or locked position.
- c. Kingpin not properly engaged.
- d. Separation between upper and lower coupler allowing light to show through from side to side.
- e. Cracks in the fifth wheel plate.
(Exceptions: Cracks in fifth wheel approach ramps and casting shrinkage cracks in the ribs of the body of a cast fifth wheel.)
- f. Locking mechanism parts missing, broken, or deformed to the extent the kingpin is not securely held.

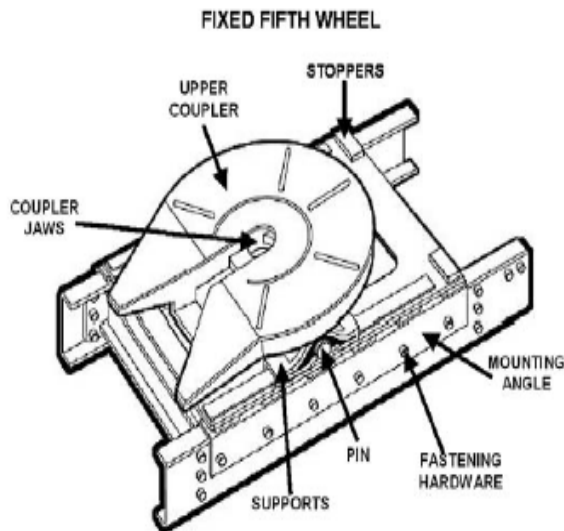
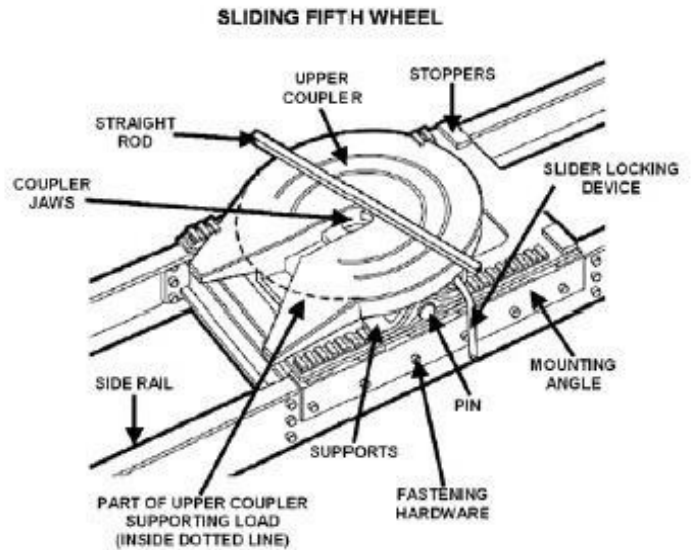

B. Inspect Pintle Hooks for and reject if:

1) Mounting to Frame:

- a. Any missing or ineffective fasteners (a fastener is not considered missing if there is an empty hole in the device but no corresponding hole in the frame or vice versa).
- b. Mounting surface cracks extending from point of attachment (e.g., cracks in the frame at mounting bolt holes).
- c. Loose mounting or frame crossmember providing pintle hook attachment cracked.

2) Integrity:

- a. Cracks anywhere in pintle hook assembly.
- b. Any welded repairs to the pintle hook.
- c. Any part of the horn section reduced by more than 20%.
- d. Latch unsecure.

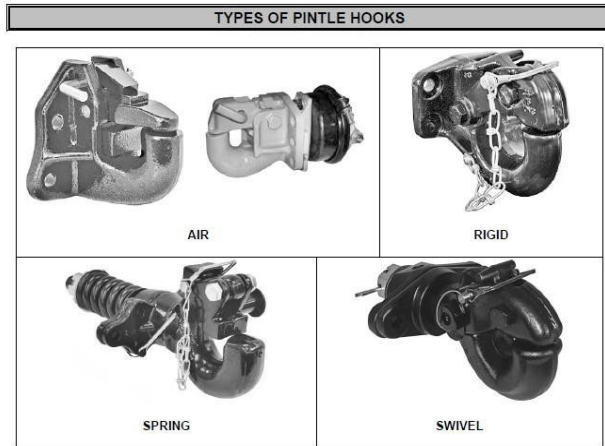

C. Inspect Drawbar/Towbar Eye for and reject if:

- 1) Mounting:
 - a. Any cracks in attachment welds.
 - b. Any missing or ineffective fasteners.
- 2) Integrity:
 - a. Any cracks.
 - b. Any part of the eye reduced by more than 20%.

D. Inspect Drawbar/Towbar Tongue for and reject if:

- 1) Slider (Power or Manual):
 - a. Ineffective latching mechanism.
 - b. Missing or ineffective stop.
 - c. Movement of more than ¼ inch between slider and housing.
 - d. Any leaking air or hydraulic cylinders, hoses, or chambers (other than slight oil weeping that is normal with hydraulic seals).
- 2) Integrity:
 - a. Any cracks.
 - b. Movement of ¼ inch between subframe and drawbar at point of attachment.

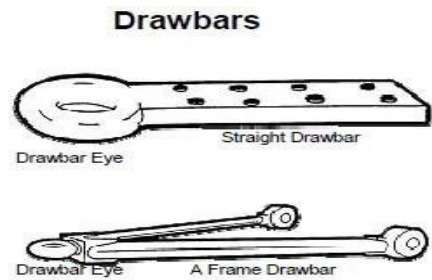

E. Inspect Safety Devices for and reject if:

- a. Safety devices missing.
- b. Unattached or incapable of secure attachment.
- c. Chains and hooks:
 - 1) Worn to the extent of a measurable reduction in link cross section.
 - 2) Improper repairs including welding, wire, small bolts, rope, and tape.
- d. Cable:
 - 1) Kinked or broken cable strands.
 - 2) Improper clamps or clamping.

F. Inspect Saddle-Mounts for and reject if:

- 1) Method of Attachment:
 - a. Any missing or ineffective fasteners.
 - b. Loose mountings.
 - c. Any cracks or breaks in a stress or load-bearing member.
 - d. Horizontal movement between upper and lower saddle-mount halves exceeds ¼ inch.

15.6 Exhaust System

A. Exhaust Emission System. The owner or operator of any new motor vehicle or new motor vehicle engine, beginning with model year 1968, equipped with an exhaust emission system shall maintain the exhaust emission system in good operable condition.

The owner or operator of the motor vehicle or motor vehicle engine shall not remove or intentionally make inoperable within the State of Texas the exhaust emission system or any part thereof, except where the purpose of removal of the exhaust emission system or part thereof is to install another exhaust emission system or part thereof, which is intended to be equally effective in reducing atmospheric emissions from the vehicle or engine.

The exhaust emission system was installed by manufacturers of motor vehicles beginning with model year 1968. The inspection of the exhaust emission system will apply only to those vehicles that are equipped with such a system. The following exhaust emission systems will be inspected if installed as original equipment by the manufacturer: thermostatic air cleaner (including flexible tubing), exhaust gas recirculation system, positive crankcase ventilation system, air injection system, evaporative emission system, and/or catalytic converter.

If installed as original equipment by the manufacturer, the catalytic converter will be considered a part of the exhaust emission system on all 1984 and later model vehicles. It will be inspected as a part of the exhaust system on prior to 1984 model vehicles, but only visually inspected for leakage. On 1984 and later model light truck and passenger vehicles, the catalytic converter will be checked for presence and leakage. Some diesel engines are equipped from the manufacturer with catalytic converters. The catalytic converter on these vehicles will also be inspected for presence and leaks only.

The inspection of the exhaust emission system shall not apply to motor vehicles **altered and modified** to use **only** a fuel other than gasoline.

1. Inspection Procedure. Examine visually and reject if:

- a. The exhaust emission system has been removed.
- b. The exhaust emission system has been

disconnected.

c. The plumbing or hoses are loose, broken, leaking, or improperly routed.

d. Air pump (air injection-type) belt is loose, removed, excessively cracked, frayed or has pieces missing.

e. The exhaust emission system has been altered in any manner to make it ineffective.

f. The catalytic converter has been removed, leaking, or disconnected on a 1984 or later model vehicle.

B. Exhaust System. Every motor vehicle shall at all times be equipped with a muffler in good working order and in constant operation.

Muffler defined: A muffler is a device consisting of a series of chambers or baffle plates or other mechanical design for the purpose of receiving exhaust gas from an internal combustion engine and/or turbine wheels for the purpose of receiving exhaust gas from a diesel engine, both of which are effective in reducing noise.

On vehicles manufactured or equipped with a muffler and a turbo, the muffler must be present and in good working order.

The exhaust system includes the manifolds, gaskets, exhaust lines, mufflers, resonators, tail piping, and supporting hardware.

Motor vehicles cannot be equipped with a muffler which is perforated or which was perforated and has been repaired, either by a muffler repair jacket or by patching or in any other way. In those cases where a muffler is perforated at the time of an inspection or has been perforated and has been repaired previous to the inspection, the muffler must be replaced or the vehicle rejected.

Some pickups are equipped with a camper or hard shell cover and are sometimes used for the transportation of passengers. The tailpipe should discharge the exhaust at the rear or sides. This truck modification will be considered as a passenger compartment.

The entire structure of a passenger vehicle or a motor home-type vehicle is considered a passenger compartment. The cab only of all other truck-type vehicles is considered a passenger or luggage compartment.

If the vehicle is equipped with lake pipes or similar devices, such pipes or devices must be securely plated and bolted or capped.

Dual exhaust systems may be modified to single exhaust systems and single exhaust systems to dual exhaust systems provided the modification does not violate requirements concerning exhaust emission systems.

Inspection of exhaust systems covers the discharge of exhaust fumes and is not concerned with the noise level.

Holes in the exhaust system made by the manufacturer for drainage are not cause for rejection. The tailpipe must direct the exhaust fumes out from under the passenger compartment.

On pickups not equipped with a camper or hard shell cover, holes or leaks in the tailpipe extending beyond the passenger compartment will not be cause for rejection.

1. Inspection Procedure. The exhaust system shall be examined visually while the engine is running to determine efficiency of the system.

2. Inspect for and reject if:

- a. Vehicle is not equipped with a muffler.
- b. Any joint is loose or leaking, including manifolds. Does not include minor leakage at exhaust control valve (manifold damper or heat riser valve).
- c. Manifold is cracked or broken causing leakage.
- d. Holes, leaking seams, or patches on the muffler, resonators, exhaust pipe, tailpipe, or catalytic converter.
- e. Exhaust system is not secured to the vehicle by mounting brackets designed for exhaust systems (wire is not acceptable).
- f. Any brackets are loose, broken, or missing.
- g. There is excessive vibration of exhaust line.
- h. Any part of the exhaust system passes through the passenger compartment.
- i. The tailpipe is broken, pinched, or eroded off to the extent to allow exhaust fumes to penetrate into the interior of the passenger compartment.

j. The tailpipe fails to discharge exhaust from the rear or sides or top of the passenger compartment of the vehicle.

k. Any exhaust system determined to be leaking at a point forward of or directly below the driver/sleeper compartment.

l. A bus exhaust system leaking or discharging to the atmosphere:

- (1) Gasoline powered – excess of 6 inches forward of the rearmost part of the bus.
- (2) Other than gasoline powered – in excess of 15 inches forward of the rearmost part of the bus.
- (3) Other than gasoline powered – forward of a door or window designed to be opened (exception: emergency exits).

m. No part of the exhaust system of any motor vehicle shall be so located as would be likely to result in burning, charring, or damaging the electrical wiring, the fuel supply, or any combustible part of the motor vehicle.

15.7 Frames

A. Inspect for and reject if:

1) Frame Members:

- a. Any cracked, broken, loose, or sagging frame members.
- b. Any loose or missing fasteners including fasteners attaching functional component such as engine, transmission, steering gear, suspension, body parts, and fifth wheel.

2) Tire and Wheel Clearance:

- a. Any condition, including loading that causes the body or frame to be in contact with a tire or any part of the wheel assembly.

3) Adjustable Axle Assemblies (Sliding Subframe):

- a. Adjustable axle assembly with locking pins missing or not engaged on.

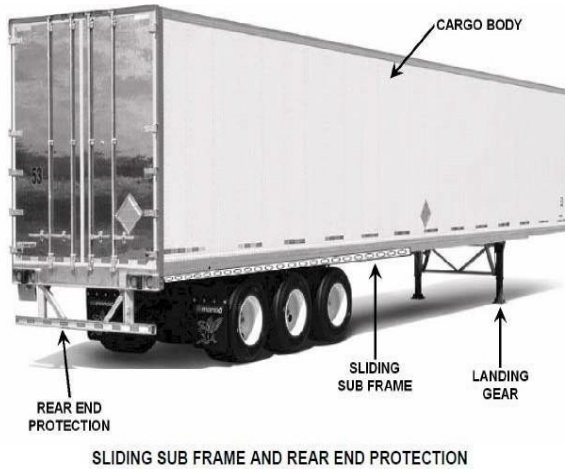
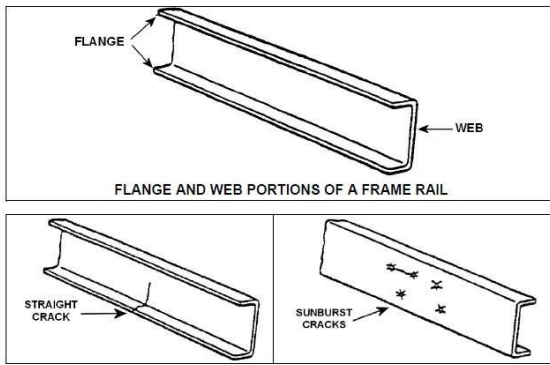

15.8 Fuel System

1. Inspect for and reject if:

- a. A fuel system with a visible leak at any point.
- b. A fuel tank filler cap missing.
- c. A fuel tank not securely attached to the motor vehicle by reason of loose, broken or missing mounting bolts or brackets (some fuel tanks use springs or rubber bushing to permit movement).
- d. Every applicable gasoline-powered vehicle from 2-24 years old will also be checked in accordance with Chapter 4 to determine if the gas cap is defective.

15.9 Hazard Warning Lamps

Every bus, truck, and truck-tractor shall be equipped with a signaling system that, in addition to signaling turning movements, shall have a switch or combination of switches that will cause the two front turn signals and the two rear signals, including the turn signal lamps on any attached trailer, to flash simultaneously as a vehicular traffic warning. The system shall be capable of flashing simultaneously with the ignition of the vehicle on or off.

1. Inspect for and reject if (Refer to Annex #3 for lighting diagrams):

- a. Lamps are not present or operational.
- b. Not securely mounted, properly located, or repaired with repair tape or repair kit.
- c. Lamp does not emit proper color (Front – Amber; Rear – Amber or Red); lens or bulb painted.
- d. Lens cracked, broken, discolored, missing, or portion of the lens is missing.
- e. Wiring insulation is worn, rubbed bare, or evidence of burning, short circuiting, or poor connection.
- f. Visibility requirements not met (At least 80 inches wide – 500 feet to the front and rear; less than 80 inches wide – 300 feet to the front and rear). LED lights have less than 50% of diodes illuminated. Lamp height is less than 15 inches or more than 72 inches.
- g. Any lamp assembly is cracked allowing water to enter or lamp assembly contains standing water.

15.10 HeadLamps

1. Motor Vehicles. Every motor vehicle shall be equipped with at least two head lamps, at least one on each side of the front of the motor vehicle, which head lamps shall comply with the requirements and limitations set forth in these regulations.

Every head lamp upon a CMV shall be located at a height of not more than 54 inches nor less than 24 inches to be measured from the center of such lamp to the level ground upon which the vehicle stands when such vehicle is without a load.

2. Motorcycles, Motor-Driven Cycles, Mopeds. Every motorcycle, motor-driven cycle, and moped shall be equipped with at least one and not more than two head lamps which shall comply with the requirements and limitations of these regulations.

3. General Provisions. All motor vehicles including motorcycles sold new after January 1, 1948, other than motor-driven cycles (motor scooters and motorbikes), must be equipped with multiple beam head lamps. Single beam head lamps will be permitted on those vehicles sold new prior to January 1, 1948, and on all motor-driven cycles (motor scooters, motorbikes, and mopeds).

There shall be an uppermost distribution of light or composite beam, so aimed and of such intensity as to reveal persons and vehicles at a distance of at least 450 feet ahead for all conditions of loading (motorcycles, motor-driven cycles, and mopeds at a distance of at least 300 feet).

There shall be a lowermost distribution of light or composite beam, so aimed and of sufficient intensity to reveal persons and vehicles at a distance of at least 150 feet ahead.

a. Single beam head lamp: A head lamp which provides only one fixed beam, which is not adjustable from the driver's seat (usually on motor-driven cycles and mopeds only).

b. Multiple beam head lamp: A head lamp which provides more than one beam, which may be selected as required from the driver's seat.

c. Dual head lamp system: Those vehicles using the dual or four head lamp system must be equipped with a combination of a #1 and a #2 type head lamps on each side of the vehicle. The use of any other type of lamp in those sockets is illegal and does not meet the inspection requirements for head lamps.

The four head lamp system must be wired to burn as originally designed.

d. Other lamps: Fog lamps, auxiliary passing lamps, auxiliary driving lamps, and parking lamps are not required to be inspected.

4. Headlight Identification:

a. **Sealed Beam Lamps:** Glass headlamps whether round or rectangular and marked with a #1 or #2 which indicates the number of filaments in the headlamp. Sealed Beam Lamps are a one piece unit with a non-replaceable inner bulb.

b. **Composite Head Lamps:** Consist of a lens, usually contoured to the grill and fenders of the vehicle, a reflector, and one or two halogen bulbs, and marked DOT or SAE on the lamp housing or the bulb. The bulb on this type of headlamp is replaceable.

c. **Projection Head Lamps:** Consist of a lens, usually contoured to the grill and fenders of the vehicle, a reflector, and one bulb with a projection lens.

d. **High Intensity Discharge (HID) Head Lamps:** Produce light via an electric arc rather than through a glowing filament. Aftermarket HID bulbs installed in composite headlamps are illegal and will not pass state inspection.

e. Head lamps approved for use on motorcycles and motor-driven cycles cannot be used on an automobile or truck and vice versa.

f. On motorcycles, motor-driven cycles, and mopeds without batteries, the engine should be run at high idle speed to observe operation of head lamp.

4. Preparation for Head Lamp Inspection.

a. Clean head lamp lenses, if necessary.

5. Inspection Procedure. Check operation and condition. (Refer to Annex #3 for lighting diagrams)

a. **Sealed Beam Head Lamps**

will be inspected and rejected if:

- (1) Lamp or Lamp assembly is not securely fastened to the vehicle. Lamp can be easily moved by hand, due to broken fender or loose support
- (2) Lamp is improperly connected or does not light the proper filament for different switch positions.
- (3) Lamps lens is cracked, broken, discolored, or missing.
- (4) Lamp is not of a type meeting Department, DOT, or SAE standards.
- (5) Wiring insulation is worn, rubbed bare, or shows any evidence of burning, short circuiting, or poor electrical connections. Wiring is dangling or connections are loose.
- (6) Lamp lens is rotated, upside down, canted, or is marked "Right", "Left", #1, or #2 and is not installed as marked.
- (7) Lamp fails to function properly in any manner, such as any filament in a head lamp that fails to burn.
- (8) Lamp has dirt, any contamination, discoloration, or moisture on the inside.
- (9) Lamp switch or dimmer switch does not operate properly or is not conveniently located for the driver.
- (10) Foreign material placed on the headlamp lens, such as shields, paint, tape, tinting, etc... that interferes with light beam of the lamp.
- (11) Vehicle is not equipped with head lamps as required or lamp is missing
- (12) Lamp or lens is other than clear.
- (13) Headlamps are not of equal intensity.
- (14) Headlamps are mounted more than or less than the prescribed mounting heights.
- (15) Lamp is covered by any lens or cover located on the front of the headlamp which is any shade of color other than clear.
- (16) There is physical damage that would obviously cause the headlamps to fail to illuminate the roadway ahead of the vehicle.

(17) Retractable Lamps: Must fully open and lock in position.

b. **Composite Head Lamps**

will be inspected for and rejected if:

- (1) Lamp or lamp assembly is not securely fastened to the vehicle. Lamp can be easily moved by hand, due to a broken fender or loose support.
- (2) Lamp is improperly connected or does not light the proper filament for the different switch positions.
- (3) Lamp lens is broken, missing, or discolored.
- (4) Lamp is not of a type meeting Department, DOT, or SAE standards.
- (5) Wiring insulation is worn, rubbed bare, or shows any evidence of burning, short circuiting, or poor electrical connections. Wiring is dangling or connections are loose.
- (6) Lamp lens is rotated, upside down, or canted.
- (7) Lamp fails to function properly in any manner, such as any filament in a head lamp that fails to burn.
- (8) Lamp has dirt, standing water, or discoloration inside.
- (9) Lamp switch or dimmer switch does not operate properly or is not conveniently located for the driver.
- (10) Foreign material placed on headlamp lens, such as shields, paint, tape, tinting, etc... that interferes with the light beam of the lamp.
- (11) Headlamp is covered by any lens or cover located in front of the headlamp which is any shade of color other than clear.
- (12) Vehicle is not equipped with headlamps as required or lamp is missing.
- (13) Lens is other than clear.
- (14) Headlamps are not of equal intensity.
- (15) Headlamps are mounted more than or less than prescribed mounting heights.

(16) There is physical damage that would obviously cause a headlamp beam to fail to illuminate the roadway ahead of the vehicle sufficiently.

(17) Retractable lamps: must fully open and lock in position.

(c). **Projection Head Lamps**

will be inspected for and rejected if:

(1) Lamp or lamp assembly is not securely fastened to the vehicle. Lamp can be easily moved by hand, due to a broken fender or loose support.

(2) Lamp is improperly connected or does not light the proper filament for the different switch positions.

(3) Lamp lens is broken, missing, or discolored.

(4) Lamp is not of a type meeting Department, DOT, SAE standards.

(5) Wiring insulation is worn, rubbed bare, or shows any evidence of burning, short circuiting, or poor electrical connections. Wiring is dangling or connections are loose.

(6) Lamp lens is rotated, upside down, or canted.

(7) Lamp fails to function properly in any manner, such as any filament in a head lamp that fails to burn.

(8) Lamp has dirt, standing water, or discoloration inside.

(9) Lamp switch or dimmer switch does not operate properly or is not conveniently located for the driver.

(10) Foreign material placed on headlamp lens, such as shields, paint, tape, tinting, etc... that interferes with the light beam of the lamp.

(11) Headlamp is covered by any lens or cover located in front of the headlamp which is any shade of color other than clear.

(12) Vehicle is not equipped with headlamps as required or lamp is missing.

(13) Lens is other than clear.

(14) Headlamps are not of equal intensity.

(15) Headlamps are mounted more than or less than prescribed mounting heights.

(16) There is physical damage that would obviously cause a headlamp beam to fail to illuminate the roadway ahead of the vehicle.

(17) Retractable lamps: must fully open and lock in position.

(d). **High Intensity Discharge Head Lamps**

will be inspected for and rejected if:

(1) Lamp or lamp assembly is not securely fastened to the vehicle. Lamp can be easily moved by hand, due to a broken fender or loose support.

(2) Lamp is improperly connected or does not light the proper bulb for the different switch positions.

(3) Lamp lens is broken, missing, or discolored.

(4) Lamp is not of a type meeting Department, DOT, SAE standards.

(5) Wiring insulation is worn, rubbed bare, or shows any evidence of burning, short circuiting, or poor electrical connections. Wiring is dangling or connections are loose.

(6) Lamp lens is rotated, upside down, or canted.

(7) Lamp fails to function properly in any manner.

(8) Lamp has dirt, standing water, or discoloration inside.

(9) Lamp switch or dimmer switch does not operate properly or is not conveniently located for the driver.

(10) Foreign material placed on headlamp lens, such as shields, paint, tape, tinting, etc... that interferes with the light beam of the lamp.

(11) Headlamp is covered by any lens or cover located in front of the headlamp which is any shade of color other than clear.

(12) Vehicle is not equipped with headlamps as required or lamp is missing.

(13) Lens is other than clear.

(14) Headlamps are not of equal intensity.

(15) Headlamps are mounted more than or less than prescribed mounting heights.

(16) There is physical damage that would obviously cause a headlamp beam to fail to illuminate the roadway ahead of the vehicle.

(17) Retractable lamps: must fully open and lock in position.

15.11 Horn

Every motor vehicle shall be equipped with a horn (electric or air) in good working order and capable of emitting a sound audible for a distance of 200 feet or more, but no horn shall emit an unreasonably loud or harsh sound or a whistle.

Bulb or hand-operated horn is acceptable if original vehicle equipment.

1. Inspection Procedure:

- a. Sound horn.
- b. Check actuating device.
- c. Examine wiring - mounting.

2. Inspect for and reject if:

- a. Vehicle is not equipped with a horn.
- b. Horn or horn switch is not securely fastened.
- c. Wiring insulation is worn, rubbed bare, or shows any evidence of burning, short circuiting, or poor connections.
- d. Horn switch not readily accessible to vehicle operator.
- e. Horn is actuated by grounding two bare wires or similar method.
- f. Sound is not audible under normal conditions for 200 feet.
- g. Horn emits an unusually loud or harsh sound or whistle.
- h. Operation of the horn interferes with the operation of any other circuit.
- i. Horn switch missing or inoperative.

15.12 Identification Lamps

All buses, trucks, and truck-tractors 80 inches or more in overall width must be equipped with three identification lamps of amber color mounted on the cab of the vehicle, one as close to the vertical center line of the vehicle as practicable and one on each side of the center line, not less than 6 inches or more than 12 inches.

All buses, trucks, and trailers 80 inches or more in overall width must be equipped with three identification lamps of red color mounted on the rear of the vehicle as high as practicable. One mounted as close as possible to the center line of the vehicle and one on each side of the center line of not less than 6 inches or more than 12 inches.

1. Inspect for and reject if: (Refer to Annex #3 for lighting diagrams)

- a. Lamps are not present.
- b. Not securely mounted, properly located or repaired with repair tape or repair kit.
- c. Lamp does not emit proper color; lens or bulb painted; or not steady burning.
- d. Lens cracked, broken, discolored, missing, or a portion of the lens is missing.
- e. Wiring insulation is worn, rubbed bare, or evidence of burning, short circuiting, or poor connection
- f. Lamps are not clearly visible in normal sunlight. LED lights have less than 50% of diodes illuminated.
- g. Any lamp assembly is cracked allowing water to enter or any lamp assembly contains standing water.

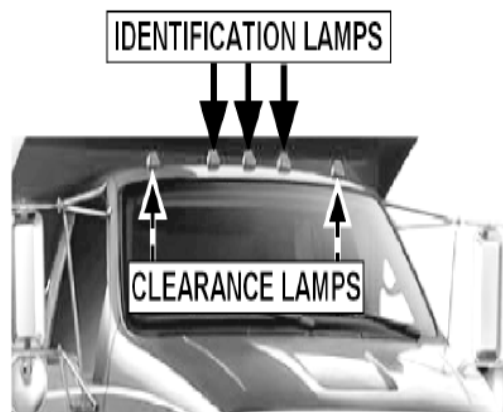

15.13 License Plate Lamp

Either a tail lamp or a separate lamp shall be so constructed and placed as to illuminate with a white light the rear registration plate and render it clearly legible for a distance of 50 feet to the rear. Any such lamp shall be so wired as to be lighted when the head lamps or auxiliary driving lamps are lighted. On vehicles such as truck-tractors which require no rear registration plate, a license plate lamp would not be required. If two license plates are issued, a license plate lamp is required.

Do not reject a vehicle because the rear registration plate is obstructed.

1. Inspection Procedure. Check operation and condition visually.
2. Inspect for and reject if: (Refer to Annex #3 for lighting diagrams)
 - a. Lamp is not present, steady burning, or operational. LED lights have less than 50% of diodes illuminated.
 - b. Lamp is not securely mounted to the vehicle.
 - c. Lamp is not placed to illuminate with a white light, the rear registration plate. (Only one lamp is required.)
 - d. Wiring insulation is worn, rubbed bare, or shows any evidence of burning, short circuiting, or poor electrical connections.
 - e. Lamp is not wired so as to be lighted when head lamps or auxiliary driving lamps are lighted.
 - f. Lamp emits a glaring light to the rear.
 - g. Lens is cracked or repaired with repair tape or repair kit. Lens or a portion of the lens is missing.
 - h. Lamp assembly is cracked allowing water to enter or the lamp assembly contains standing water.
 - i. Lamp does not meet the visibility requirement.

15.14 Mirrors

Every bus, truck, and truck-tractor shall be equipped with two rear-vision mirrors, one at each side, firmly attached to the outside of the motor vehicle, and so located as to reflect to the driver a view of 200 feet to the rear, along both sides of the vehicle.

Only one outside mirror shall be required, which shall be on the driver's side, on trucks which are so constructed that the driver has a view to the rear by means of an interior mirror.

In driveaway-to-way operations, the driven vehicle shall have at least one mirror furnishing a clear view to the rear.

1. Inspect for and reject if:
 - a. Proper number of mirrors not present
 - b. Mirror does not provide clear view to rear of 200 feet.
 - c. Mirror creates interference with driver's forward vision.
 - d. Reflective surface of mirrors is cracked, broken, peeled, tarnished, or has sharp edges.
 - e. Mirror not mounted securely to prevent swing or excessive vibration.

15.15 Reflective Sheeting/Reflex Reflectors - Conspicuity System

Truck-tractors manufactured on or after July 1, 1997 and any trailer or semi-trailer manufactured on or after December 1, 1993 that is 80 inches or more wide and 10,001 pounds or more GVWR, except pole trailers and mobile office/housing trailers, require conspicuity materials (retroreflective sheeting and/or reflex reflectors meeting the requirements of FMVSS No. 108). If the GVWR plate is not present on a trailer or semi-trailer, then an actual or registered weight of 10,001 pounds or more will apply. Trailers and semi-trailers manufactured before December 1, 1993 are required to be retrofitted with the conspicuity system, except for pole trailers and mobile office/housing trailers.

Refer to Annex #4 for conspicuity system requirement diagrams for trailer types and truck-tractors.

A. Inspection Procedure. Inspect for proper placement, coverage, and color of the conspicuity system.

1. Color combinations of red and white shall be used, beginning with red or white, along the sides and lower rear of the trailer.
2. The centerline for each reflective strip shall be between 15 inches and 60 inches above the road surface or as close as practicable with the trailer empty.
3. Must be an approved type. The manufacturer certification will consist of one of the following markings:
 - a. DOT – C (Rectangular Reflex Reflectors);
 - b. DOT – C2, 2 inch (50mm);
 - c. DOT – C3, 3 inch (75mm); or
 - d. DOT – C4, 4 inch (100mm).

B. Inspect for and reject if:

1. Trailer is not equipped with reflective sheeting, tape, or reflex reflectors.

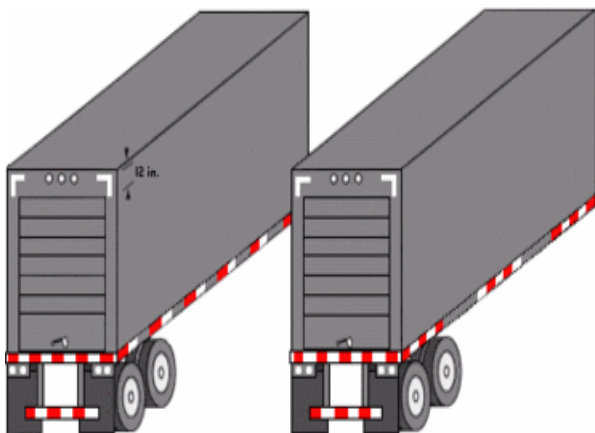

2. Not properly placed or secured to the trailer or proper colors used:

- a. on each side placed horizontally:
 - (1) the total length of the sections do not equal to at least one half of the total length of the trailer.
 - (2) the placement is not reasonably evenly distributed down the full length of the trailer and as near the front and rear as practicable.
- b. on the lower rear, placed horizontally:
 - (1) the total length does not extend as near as practicable across the full rear of the trailer.
 - (2) the placement is not as low as practicable.
- c. on the underside protection device, if equipped:
 - (1) placed horizontally across the full width of the device.
- d. on the upper rear:
 - (1) the placement is not as close as practicable to the extreme outer and upper dimensions of the trailer.
 - (2) two pairs of white reflective sheeting or reflex reflectors, each section at least 12 inches long, must be positioned horizontally and vertically on the right and left upper corners of the rear of the body.
 - (3) the reflective material is not white in color.

3. Reflective material is excessively discolored, deteriorated, or painted; to the extent the ability to reflect is substantially affected.



4. Truck-tractor is not equipped with reflective sheeting as follows:

a. Upper rear of the cab:

(1) Two pairs of white reflective sheeting or reflex reflectors, each section at least 12 inches long, must be positioned horizontally and vertically on the left and right upper corners of the rear of the cab body.

(2) Lower rear of the truck tractor: Red and white sheeting or reflex reflectors on the mounting bracket of the safety guard (mud flap).

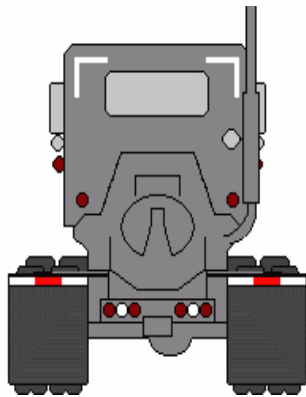

15.16 Reflectors(Rear/Side)

A. Reflectors (Rear). Every motor vehicle, trailer, semitrailer, and pole trailer shall carry on the rear, either as a part of the tail lamps or separately, two or more red reflectors. Motorcycles, motor-driven cycles, and mopeds shall have mounted on the rear, either as a part of the tail lamp or separately, at least one red reflector.

Every reflector upon any vehicle shall be of such size and characteristics and so mounted as to be visible at night from all distances within 600 feet to 100 feet from such vehicle when directly in front of the lawful lower beams of head lamps, except that reflectors on passenger cars, motorcycles, and motor-driven cycles manufactured or assembled prior to January 1, 1972, shall be visible at night from all distances within 350 feet to 100 feet when directly in front of lawful upper beams of the head lamps.

Reflectors on all motor vehicles shall be mounted at a height of not less than 15 inches, nor more than 60 inches measured from the center of such reflector to the level ground upon which the vehicle stands.

If the highest part of the permanent structure of the vehicle is less than the height required, the reflector shall be mounted as high as that part of the permanent structure will permit.

Rear reflectors on a vehicle shall reflect a red color. Red reflectors required on the rear of a vehicle may be incorporated with the tail lamp assembly.

Required rear reflectors shall be mounted with one on each side of the center of the vehicle.

Rear reflectors on pole trailers may be mounted on each side of the bolster or load.

Refer to Annex #3 for lighting diagrams.

1. Inspection Procedure. Check condition and mounting.

2. Inspect for and reject if:

- a. Reflector is not present.
- b. Reflector is not of red color.
- c. Reflector is not properly and/or securely mounted to the vehicle.
- d. Reflector is cracked to the extent that the reflecting ability is impaired.
- e. Reflector is discolored, deteriorated, or painted.
- f. Visibility distance is not as required.
- g. Requirements shown on lighting diagram are not met (Annex #3). Reflector height requirements are not met.

B. Reflectors (Side).

1. Required on all:

- a. Buses 80 inches or more in overall width.
- b. Trucks 80 inches or more in overall width.
- c. Trailers and semitrailers 80 inches or more in overall width.
- d. Trailers and semitrailers 30 feet or more in overall length.
- e. Poletrailers.

2. Every required reflector upon any of the above described commercial vehicles shall be of such size and characteristics and so maintained as to be readily visible at nighttime from all distances within 600 feet to 100 feet from the vehicle when directly in front of the lawful lower beams of head lamps, except that the visibility for reflectors on vehicles manufactured or assembled prior to January 1, 1972, shall be measured in front of lawful upper beams of head lamps.

3. Reflectors on commercial vehicles should be mounted at a height of not less than 15 nor higher than 60 inches above the ground on which the vehicle stands.

a. If the highest part of the permanent structure of the vehicle is less than the height required, the reflector shall be mounted as high as that part of the permanent structure will permit.

b. Reflectors mounted on the sides near the front of a vehicle shall reflect an amber color.

c. Reflectors mounted on the sides near the rear of a vehicle shall reflect a red color.

d. On buses and trucks 80 inches or more in overall width and trailers and semitrailers 80 inches or more in overall width:

1) On each side, two reflectors, one at or near the front (amber) and one at or near the rear (red).

e. On trailers and semitrailers 30 feet or more in overall length:

1) On each side one amber reflector, centrally located with respect to the length of the vehicle.

f. On pole trailers:

1) One amber reflector at or near the front of the load (if loaded.)

g. Trailers which are equipped with approved conspicuity material (reflective sheeting) are not required to be equipped with the side reflex reflectors required in this part if:

1) The conspicuity material is placed at the locations where reflex reflectors are required; and

2) The conspicuity material when installed on the trailer meets the geometric visibility requirements for the reflex reflectors.

3) See Annex #4 for conspicuity requirements.

4. Inspection Procedure. Check condition and mounting.

5. Inspect for and reject if:

a. Reflectors are not present.

b. Reflectors are not of the required color for the location on the vehicle.

c. Reflectors are not properly and/or securely mounted to the vehicle.

d. Reflector is cracked to the extent that the reflecting ability is impaired.

e. Reflectors are discolored, deteriorated, or painted.

f. Requirements shown on lighting diagram are not met (Annex #3). Reflector height requirements are not met.

g. Visibility distance is not as required.

15.17 Safety Guards or Flaps

A. Safety guards or flaps are required on all trucks, trailers, or semi-trailers (in combination with a towing vehicle), if the rearmost axle of the vehicle (or combination) has at least four tires or at least two super single tires. A super single tire is a wide-base, single tire that may be used in place of two standard tires on the same axle.



Super Single Tires

Safety guards or flaps are not required on:

- 1) Buses;
- 2) Motorhomes;
- 3) Pole trailers; or
- 4) Truck-tractors.

Safety guards or flaps shall be located and suspended behind the rearmost wheels of such vehicle or if in combination behind the rearmost wheels of such combination to within 12 inches of the surface of the roadway. Safety guards or flaps shall be of metal, rubber, rubberized material, or other substantial material, capable of remaining in place behind the rear wheels by their own weight while the said vehicle is being operated.

When trailers and semitrailers are presented for inspection in combination, each trailer or semitrailer will be considered a separate vehicle and safety guards or flaps will be required on the rearmost axle of each trailer or semitrailer.

1. Inspection Procedure. Check for presence and condition.

2. Inspect for and reject if:
 - a. Safety guard or flap is not present.
 - b. Safety guard or flap is not securely mounted.
 - c. Safety guard or flap is not as wide as the tires that it is protecting.
 - d. Safety guard or flap is split or torn to the extent that it is ineffective.
 - e. The bottom edge of safety guard or flap is more than twelve (12) inches from the surface of the roadway.

15.18 Seat Belts

A. Front seat belts are required on every motor vehicle in which front seat belt anchorages were a part of the manufacturer's original equipment on the vehicle.

Anchorage defined: A seat belt anchorage consists of a threaded hole in a suitable structure to receive the seat belt attachment fittings or a circular anchor which is welded to the vehicle chassis. Self-treading bolts are inserted into the anchor to form the complete seat belt anchorage assembly.

1. Inspection Procedure. Inspect front lap seat belts for frayed, split, or torn webbing; malfunctioning buckles; and loose or damaged anchorages to the floor pan. Vehicles originally equipped with automatic seat belts (shoulder belts) without front lap seat belts will have the automatic belts inspected.

Front lap belts only will be inspected in all other vehicles. The ignition seat belt interlock system is not an item of inspection.

2. Inspect for and reject if:
 - a. Front lap seat belts are required and not present.
 - b. Seat belt webbing is frayed, split, or torn.
 - c. Belt buckles loose or inoperative.
 - d. Belt Anchorages or attachment fittings are loose, badly corroded, missing, or not fastened to belt.

- e. All seat belt anchor bolts are not securely fastened to floor or are missing.
- f. Pelvic restraint is not present.
- g. Seat belt will not adjust to allow proper fit.

15.19 Side Marker Lamps

1. Required on all:

- a) Buses 80 inches or more in overall width. Trucks 80 inches or more in overall width.
- b) Trailers and semitrailers 80 inches or more in overall width.
- c) Trailers and semitrailers 30 feet or more in overall length.
- d) Poletrailers.
 - a. Side marker lamps shall, so far as is practicable, be mounted on the permanent structure of the vehicle in such a manner as to indicate the length of the vehicle.
 - b. Side marker lamps and clearance lamps may be mounted in combination, provided illumination is given as required by law.
 - c. Side marker lamps mounted on the front or on the sides near the front of a vehicle shall display an amber color.
 - d. Side marker lamps mounted on the rear or on the sides near the rear of a vehicle shall display a red color.
 - e. Side marker lamps shall be visible under normal atmospheric conditions at a distance between 500 feet and 50 feet from the vehicle on which mounted.
 - f. On buses and trucks 80 inches or more in overall width and trailers and semitrailers 80 inches or more in overall width:
 - 1) Two side marker lamps, one on each side, one at or near the front and one at or near the rear.

g. All trailers and semitrailers 30 feet or more in overall length are required to have mounted centrally located with respect to the length of the vehicle:

- 1) On each side, one amber side marker lamp.
- h. On pole trailers:

- 1) On each side, one amber side marker lamp at or near the front of the load (if loaded).
- 2) On the rearmost support for the load, one combination marker lamp showing amber to the front and red to the rear and side, or cluster of required color lamps.

2. Inspection Procedure. Check operation and condition visually.

3. Inspect for and reject if: (Refer to Annex #3 for lighting diagrams)

- a. Lamps are not present.
- b. Lamps are not securely mounted, properly located, or repaired with repair tape or repair kit.
- c. Lamps do not emit required color; lens or bulb painted; or not steady burning.
- d. Visibility requirements are not met. LED lights have less than 50% of diodes illuminated.
- e. Lenses are discolored, missing, or a portion of the lens is missing.
- f. Wiring insulation is worn, rubbed bare, or shows any evidence of burning, short circuiting, or poor electrical connections.
- g. Lens is cracked.
- h. Any lamp assembly is cracked allowing water to enter or lamp assembly contains standing water.
- i. Requirements shown on lighting diagram are not met (See Annex #3). Side marker lamp height requirements are not met.

15.20 Steering Mechanism

A. The steering system of the vehicle must be inspected to determine if excessive wear and/or maladjustment of the steering linkage and/or steering gear exists. Wear and adjustment of the steering system will be checked by measuring lash. The vehicle must be on a dry surface.

Lash defined: Lash is the condition in which the steering control can be turned through some part of a revolution without front wheel motion. The wheels should be loaded and positioned straight ahead.

Jamming defined: Jamming is any obstruction to the turning of the steering control caused by interference between some components of the steering system. The obstruction would include tires too large or damaged fenders that would interfere with a full right or left turn.

B. Inspection Procedure. Lash or Free Play: With steering axle tires in straight ahead position, turn steering wheel until the turning motion can be observed at the steering axle tires. Measure lash. On vehicles equipped with power steering the engine must be running.

C. Inspect for and reject if:

1) Steering Lash (See Chart Below):

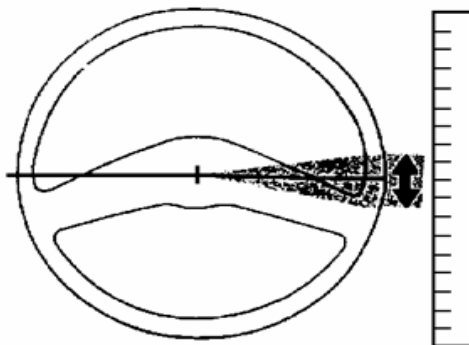

Steering Wheel Diameter	Manual Steering System	Power Steering System
16"	2"	4 1/2"
18"	2 1/4"	4 3/4"

For steering wheel diameters not listed, the steering wheel lash shall not exceed 14 degrees angular rotation for manual steering systems and 30 degrees angular rotation for power steering systems.

2) Steering Column:

- a. Any absence or looseness of U-bolt(s) or position parts on steering column.
- b. Worn, faulty or obviously repair welded universal joint(s) on steering column.
- c. Steering wheel not properly secured or not securely mounted to the steering shaft.
- d. Tilt steering wheel fails to lock into position.
- e. On vehicles equipped with flexible couplings, or energy-absorbing steering columns, when it is obvious through a visual inspection of the vehicle that the column has been damaged and is in an unsafe condition, it should be rejected.

3) Steering System:

- a. It is impossible to turn the steering wheel from full right to full left without binding or jamming other than at wheel stops.
- b. Modification of the steering system so as to affect the proper steering of the vehicle or steering wheel has been modified or replaced with one that is noticeably smaller than original factory equipment.
- c. Any modification or other condition that interferes with free movement of any steering component.
- d. Steering mechanism is not firmly attached and free of frame cracks or missing bolts.
- e. On motorcycles and motor-driven cycles, handlebars or steering head is bent, loose, broken or damaged so as to cause unsafe condition in steering.

4) Front Axle Beam and All Steering Components Other than Steering Column:

- a. Any crack or obvious welded repair(s).

5) Steering Gear Box:

- a. Any mounting bolt(s) loose or missing.
- b. Any crack(s) in gear box or mounting brackets.

6) Pitman Arm:

- a. Any looseness of the pitman arm on the steering gear output shaft.

7) Power Steering. On vehicles equipped with power steering, the fluid level, belt tension and belt condition must be inspected for compliance before starting the engine to check for proper operation of the steering.

- a. Auxiliary power assist cylinder loose.
- b. Visible leaks in power steering unit or hoses.
- c. Power steering belt is excessively cracked, frayed, or has pieces missing or tension is not adequate. Serpentine belts are not to be rejected merely for cracks in the ribs.
- d. Fluid in power steering unit is below manufacturer's recommended level. Do not overfill.

8) Ball and Socket Joints:

- a. Any movement under steering load of a stud nut.
- b. Any motion, other than rotational, between any linkage member and its attachment point of more than 1/4 inch.

9) Tie Rods and Drag Links:

- a. Loose clamp(s) or clamp bolt(s) on tie rods or drag links.
- b. Any looseness in any threaded joint.

10) Nuts:

- a. Nut(s) loose or missing on tie rods, pitman arm, drag link, steering arm, or tie rod arm.

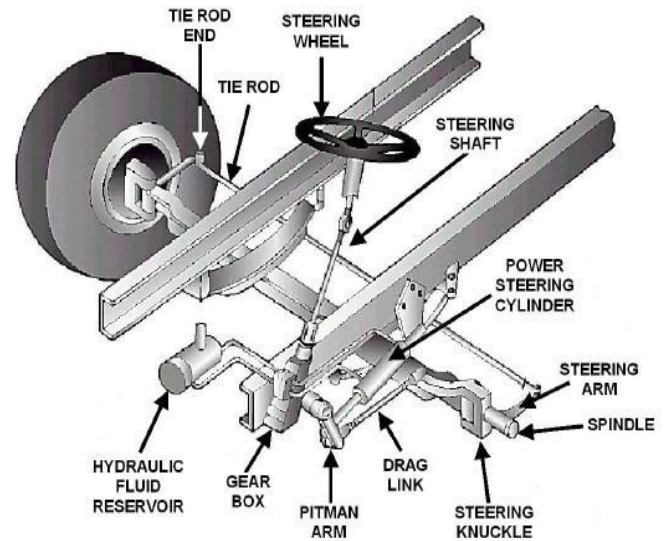

15.21 Stop Lamps

Every motor vehicle, trailer, semitrailer, and pole trailer shall be equipped with two or more stop lamps, except motorcycles and motor-driven cycles, which require one stop lamp. Passenger cars and trucks manufactured or assembled prior to the model year 1960 shall be equipped with at least one stop lamp.

A stop lamp on a CMV must emit a red light and be visible from a distance of not less than 300 feet to the rear in normal sunlight. The stop lamp shall be actuated upon application of the service brake and which may, but need not, be incorporated with one or more other rear lamps.

1. Inspection Procedure. Check operation and condition visually.
2. Inspect for and reject if: (Refer to Annex #3 for lighting diagrams)
 - a. Required lamp or lamps are not present.
 - b. Lamp is not securely mounted to the vehicle.
 - c. Lamp does not emit a steady burning red light which is actuated on application of the service (foot) brake.
 - d. Lamp is not visible from a minimum distance of 300 feet to the rear of the vehicle to which it is attached. LED lights have less than 50% of diodes illuminated. Lamp height is less than 15 inches or more than 72 inches.
 - e. Lamp lens is painted, missing; a portion of the lens is missing, discolored, does not fit properly, or repaired with repair tape or repair kit.
 - f. Wiring is shoddy or electrical connections are poor.
 - g. Lamp projects a glaring or a dazzling light.
 - h. Lamp is not mounted on rear of vehicle.
 - i. Lens is cracked.
 - j. Any lamp assembly is cracked allowing water to enter or the lamp assembly contains standing water.
 - k. Lamps are not of equal intensity.

Number of Stop Lamps Required for a Commercial Vehicle Inspection:

- a. Passengers cars manufactured prior to model year 1960: 1 Stop Lamp
- b. Passenger cars manufactured in model year 1960 to model year 1984: 2 Stop Lamps
- c. Passenger cars manufactured on or after September 1, 1985 to present: 2 Stop Lamps and a Center High-Mount Stop Lamp
- d. Multipurpose passenger vehicle (e.g. SUV, pickup truck, vans), truck, bus, whose overall width is less than 80 inches, whose GVWR is 10,000 lbs. or less, manufactured before September 1, 1993: 2 Stop Lamps

- e. Multipurpose passenger vehicle (e.g. SUV, pickup truck, vans), truck, bus, whose overall width is less than 80 inches, whose GVWR is 10,000 lbs. or less, manufactured on or after September 1, 1993: 2 Stop Lamps and a Center High-Mount Stop Lamp
- f. Commercial vehicles 80 inches or more in width and whose GVWR is 10,001 lbs. or more: 2 Stop Lamps
- g. Trailers, Semitrailers, Pole Trailers: 2 Stop Lamps
- h. Motorcycles and motor-driven cycles: 1 Stop Lamp

3. Center High Mount Stop Lamp:

Each passenger car manufactured on or after September 1, 1985, and each multipurpose passenger vehicle (e.g. SUV), truck, bus, whose overall width is less than 80 inches, whose GVWR is 10,000 lbs. or less, manufactured on or after September 1, 1993, shall be equipped with a center high-mounted stop lamp. A center high-mounted stop lamp cannot be substituted for any other required stop lamps.

1. Inspection Procedure. Check operation and condition visually.
2. Inspect for and reject if:
 - a. . Required lamp is not present. This light will not be inspected if obstructed by camper shells, tool boxes, luggage racks etc. However, if the camper shell is equipped with a center high mount stop lamp, it must be operational at the time of inspection.
 - b. Lamp is not securely mounted to the vehicle.
 - c. Lamp does not emit a steady burning red light which is actuated on application of the service (foot) brake.
 - d. Lamp is not visible from a minimum distance of 300 feet to the rear of the vehicle. The center high-mounted stop lamp has less than 50% of its bulbs or LED diodes illuminated.

- e. Lamp lens is painted, missing, discolored, or does not fit properly. Any aftermarket tint has been applied over the Center High-Mount Stop Lamp.
- f. Wiring is shoddy or electrical connections are poor.
- g. Lamp projects a glaring or a dazzling light.
- h. Lamp is not mounted on rear of vehicle.
- i. Lens is cracked or broken to the extent that a portion of the lens is missing and/or separated, permitting light from the bulb to emit through the crack or break.
- j. Center High-Mount Stop Lamp must be located on the centerline of the vehicle if manufacturer equipped.
- k. Lamp lenses repaired with repair tape or repair kit.
- l. Lamp assembly is cracked allowing water to enter or the lamp assembly contains standing water.

- h. Deflated air suspension, i.e. system failure, leak, etc.
- i. Any part of a torque, radius, or tracking component assembly or any part used for attaching the same to the vehicle frame or axle is cracked, loose, broken, or missing. Does not apply to a loose bushing in torque or track rods.

15.22 Suspension

1. Inspect for and reject if:
 - a. U-bolt, spring hanger, or other axle positioning parts are cracked, broken, loose, or missing.
 - b. Any leaves in a leaf spring assembly are broken or missing.
 - c. Any broken main leaf in a leaf spring assembly (includes assembly with more than one main spring).
 - d. Coil spring broken.
 - e. Rubber spring missing.
 - f. One or more leaves displaced in a manner that could result in contact with a tire, rim, brake drum, or frame.
 - g. Broken torsion bar spring in a torsion bar suspension.

DAMAGED SPRING SUSPENSION

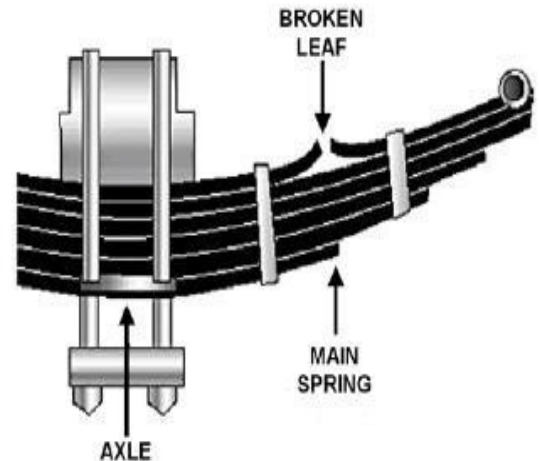

AUXILIARY OR HELPER SPRING SUSPENSION

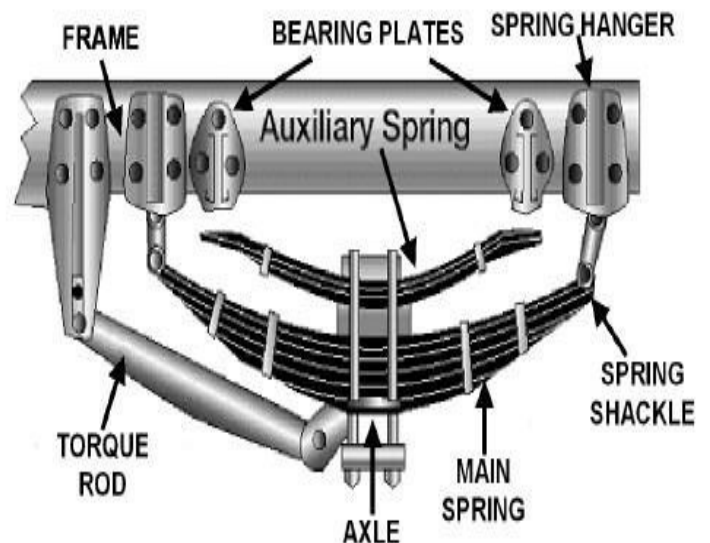

TYPICAL REAR AXLE SUSPENSION

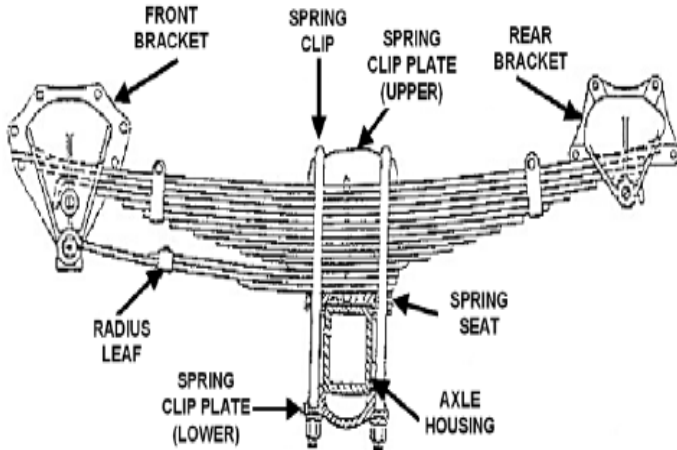

15.23 TailLamps

Every motor vehicle, trailer, semitrailer, pole trailer, and any other vehicle which is being drawn at the end of a combination of vehicles shall be equipped with at least two tail lamps mounted on the rear which, when lighted, shall emit a red light plainly visible from a distance of 1,000 feet to the rear. Tail lamps shall be mounted on the same level and as widely spaced laterally as practicable.

Every tail lamp upon every CMV shall be located at a height of not more than 72 inches nor less than 15 inches. Tail lamps are used only to designate the rear of a vehicle.

At least two tail lamps are required on all motor vehicles, trailers, semitrailers, and pole trailers, except that at least one tail lamp is required on motorcycles, motor-driven cycles, and mopeds and all 1959 model year and earlier passenger cars and trucks.

1. Inspection Procedure. Check operation and condition visually. Vehicles that are equipped from the manufacturer with approved lenses which are clear and lighted by LED lights will pass state inspection. Vehicles that are equipped with aftermarket lenses which are clear and lighted by a red bulb will be rejected. There are no red bulbs currently approved for use on vehicles.

2. Inspect for and reject if: (Refer to Annex #3 for lighting diagrams)

- a. Required lamp or lamps are not present.
- b. Lamp is not securely mounted to vehicle.
- c. Lamp does not emit a steady burning red light plainly visible 1,000 feet to the rear. LED lights have less than 50% of diodes illuminated.
- d. Lamp lens is painted, missing, discolored, does not fit properly, or repaired with repair tape or repair kit.
- e. Wiring is shoddy or electrical connections are poor.
- f. Lamp is not wired so as to be lighted when head lamps or auxiliary driving lamps are lighted.
- g. Lamp is obstructed by any part of the body
- h. Lamp does not emit a red color
- i. Lamps are not mounted on the same level and as widely spaced laterally as practicable. Lamp height is less than 15 inches or more than 72 inches.
- j. Lamps are not mounted on rear of vehicle.
- k. Lens is cracked, missing, or a portion of the lens is missing.
- l. Any lamp assembly is cracked allowing water to enter or lamp assembly contains standing water.
- m. Lamps are not of equal intensity.

15.24 Tires

1. Inspect any tire on Steering Axle for and reject if:
 - a. Has less than 4/32-inch tread when measured at any point on a major tread groove.
 - b. Has body ply or belt material exposed through the tread or sidewall.
 - c. Has any tread or sidewall separation.
 - d. Has a cut where the ply or belt material is exposed.
 - e. Labeled “Not for Highway Use” or displaying other marking which would exclude use on the steering axle.
 - f. Any bus equipped with regrooved, recapped or retreaded tires on the steering axle.
 - g. A truck or truck-tractor with regrooved tires with a load-carrying capacity equal to or greater than 4,920 pounds on the steering axle.
 - h. A tube-type radial tire without radial tube stem markings. These markings include a red band around the tube stem, the word “radial” embossed in metal stems, or the word “radial” molded in rubber stems.
 - i. Mixing bias and radial tires on the steering axle.
 - j. The tire flap protrudes through valve slot in rim and touches stem.
 - k. Boot, blowout patch, or other ply repair.
 - l. Weight carried exceeds tire load limit. This includes overloaded tire resulting from low air pressure.
 - m. Tire is flat or has noticeable (e.g., can be heard or felt) leak.
 - n. So mounted or inflated that it comes in contact with any part of the vehicle.
2. Inspect all other tires and reject if:
 - a. Weight carried exceeds tire load limit. This includes overloaded tire resulting from low air pressure.

- b. Tire is flat or has noticeable (e.g., can be heard or felt) leak.
- c. Has body ply or belt material exposed through the tread or sidewall.
- d. Has any tread or sidewall separation.
- e. Has a cut where ply or belt material is exposed.
- f. So mounted or inflated that it comes in contact with any part of the vehicle. (This includes a tire that contacts its mate).
- g. Is marked “Not for Highway Use” or otherwise marked and having like meaning.
- h. Has less than 2/32-inch tread when measured at any point on a major tread groove.

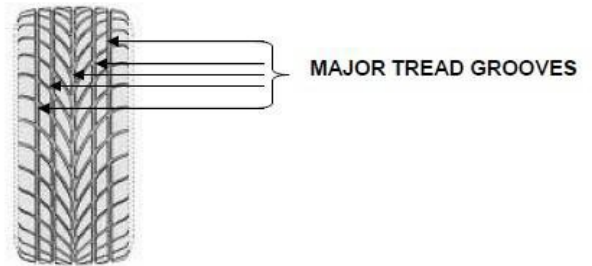

15.25 Turn Signal Lamps

Every motor vehicle, trailer, semitrailer, and pole trailer shall be equipped with electrical turn signal lamps, except that passenger cars and trucks less than 80 inches in width and manufactured or assembled prior to the model year 1960 need not be equipped with electrical turn signal lamps.

If the bed, body, cab, load, and any other equipment on a vehicle or combination of vehicles exceeds 24 inches or more to the left of the center of the top of the steering post in the same horizontal plane (that is, as high as the center of the top of the steering post) or when the distance from the center of the top of the steering post to the rear limit of the body or load exceeds 14 feet, then turn signal lamps are required, even though a hand and arm signal can be seen and the vehicle was manufactured or assembled prior to model year 1960.

Required turn signal lamps must be visible to the front and to the rear of the vehicle.

1. Electric turn signal lamp types:

- a. Single-faced units.
- b. Double-faced units.
- c. Arrow-faced units.
- d. Kits designed to be used in conjunction with the parking light assembly.

2. Electric turn signal lamp flashers. All open-faced and arrow-type turn signal lamps must flash on and off in order to clearly indicate an intention to turn.

Turn signal lamps are required on those vehicles manufactured with a right-hand (steering wheel) drive, regardless of model year.

A single lamp (large double-faced unit) on each side of a truck-tractor, which is visible to the front and rear, will suffice for turn signal lamps.

3. Turn signal lamp mounting. The lamps on a CMV showing to the front shall be mounted on the same level and as widely spaced laterally as practicable and, when signaling, shall emit amber light.

The lamps showing to the rear shall be mounted on the same level and as widely spaced laterally as practicable and, when signaling, shall emit a red or amber light.

Turn signal lamps on vehicles 80 inches or more in overall width shall be visible from a distance of not less than 500 feet to the front and rear in normal sunlight. Turn signal lamps may, but need not, be incorporated in other lamps on the vehicle.

Turn signal lamps shall indicate an intention to turn by flashing lamps showing to the front and rear of a vehicle. On a combination of vehicles, turn signal lamps shall indicate an intention to turn by flashing lamps to that side of the vehicle or combination toward which the turn is to be made.

Motorcycles, motor-driven cycles, and mopeds are not required to be equipped with turn signal lamps.

Semaphore or mechanical arm devices are not acceptable as turn signal lamps.

4. Inspection Procedure. Check operation and condition visually.

5. Inspect for and reject if: (Refer to Annex #3 for lighting diagrams)

- a. Lamps are required and not present.
- b. Device is not securely mounted or properly located on the vehicle. Lamp height is less than 15 inches or more than 83 inches.
- c. Device is not of a type meeting Department standards.
- d. Lamp lens is painted, discolored, missing, or a portion of the lens is missing. Lamp lenses cannot be repaired with repair tape or repair kit.
- e. Wiring insulation is worn, rubbed bare, or shows any evidence of burning, short circuiting, or poor electrical connections.
- f. Switch is not convenient to driver or indicator light does not operate. Selector switch must lock in proper turn position when applied but need not cancel automatically.
- g. Signal shows any color other than amber to front, or signal shows any color other than red or amber to the rear.
- h. Signal does not flash or is not operating properly.
- i. Signal is not clearly visible to the front and to the rear of the vehicle for the required distance. LED lights have less than 50% of diodes illuminated.

- j. Lens is cracked.
- k. Any lamp assembly is cracked allowing water to enter or the lamp assembly contains standing water.
- l. Lamps are not of equal intensity.

15.26 Vehicle Identification Number (VIN)

Vehicle Identification Number, Motor, or Serial Number: Make an actual physical check of the motor block, frame, or body part where such number is located and record same on the vehicle inspection report. The entire vehicle identification number must be used. Do not reject a vehicle because it has no vehicle identification number or motor or serial number.

Vehicles with altered or removed vehicle identification numbers or motor or serial numbers should be reported to your Department representative.

15.27 Wheels and Rims

1. Inspection Procedure. The inspection of all wheels and rims will be visual. Spare wheels and rims will not be inspected. Wheel covers or hubcaps may be removed from the vehicle if the certified inspector has probable cause or reason to believe that wheel or rim defects exist.

2. Inspect for and reject if:

- a. Any loose, missing, broken, cracked, stripped, damaged or otherwise ineffective wheel studs, bolts, nuts, or lugs.
- b. Any part of the wheel is bent, cracked, or damaged so as to affect safe operation of the vehicle.
- c. Wheel nuts, studs, and clamps which are loose, broken, missing, or mismatched. Adequate thread engagement is imperative. Stud and nut threads on wheel lugs must engage completely through the entire threaded portion of the nut.
- d. Lock or side rings which are bent, broken, cracked, improperly seated, sprung or mismatched ring(s) or otherwise damaged. Check for evidence of rim slippage - this is an indication of wear or loose nuts.

e. Disc wheels with elongated bolts, holes, or cracks between hand holes or stud holes, or both.

f. Cast wheels with cracks, evidence of wear in the clamp area, or both.

g. Rims have defects or cracks to the extent that they impair the safe mounting and proper retention of tires.

h. Any wheel cannot be securely fastened to the hub of the vehicle.

i. Welds

1. Any cracks in welds attaching disc wheel disc to rim.

2. Any crack in welds attaching tubeless demountable rim to adapter.

3. Any welded repair on aluminum wheel(s) on a steering axle.

4. Any welded repair other than disc to rim attachment on steel disc wheel(s) mounted on the steering axle.

j. On motorcycles and motor-driven cycles, any spokes are bent, loose, broken, or missing.

15.28 Window Tinting or Coating

1. Inspection Procedure. Utilize calibrated tint meter to check window tinting or coating.

2. Inspect for and reject if: (All year models)

- a. Coloring or tinting of windshields if the light transmittance through the colored or tinted glazing is less than 70% of the normal light transmittance. The measurement for light transmittance should not be taken in the 2 inch border at the top of the windshield, a 1 inch border at each side of the windshield, or in the area below the topmost portion of the steering wheel. Check tint meter calibration before rejecting vehicle.

- b. Windows, immediately to the right and left of the driver, have less than 70% light transmittance. Check tint meter calibration before rejecting vehicle.
- c. Tinting is red, blue, or amber in color or is a reflectivetype.
- d. Vehicles with windows immediately to the right or left of the driver that cannot be raised or lowered for inspection of the window tint.

15.29 Windshield

Windshield damage should not be assessed in the 2 inch border at the top of the windshield, a 1 inch border at each side of the windshield, or in the area below the topmost portion of the steering wheel.

1. Inspect for and reject if:

- a. Any crack over ¼ inch wide.
- b. Any damaged area of larger than ¾ inch diameter.
- c. Any damaged area of ¾ inch diameter if closer than 3 inches to any other similarly damaged area.
- d. Any crack less than ¼ inch wide intersecting with any other crack.

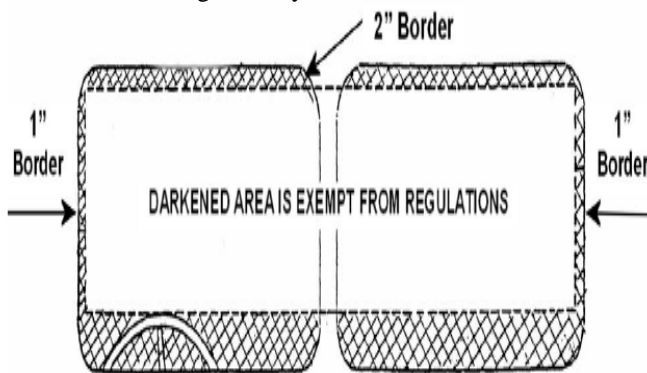

15.30 Windshield Wipers

Every motor vehicle with a windshield must be equipped with a windshield wiper or wipers adequate for cleaning rain, snow, or other moisture from the windshield; in good working order; and constructed so as to permit operation and control by the driver of the vehicle.

All motor vehicles which were originally equipped (manufactured) with one wiper, only one wiper is required; if originally equipped (manufactured) with two or more wipers, all wipers will be required. Replacement of vacuum with electric

or electric with vacuum wipers is permissible.

1. Inspection Procedure. Inspect for satisfactory operation. If vacuum operated, engine must be idling and control full on. Inspect for proper contact of blades with windshield. Raise arm away from windshield and release. Arm should return to original position and wiper blade should contact the windshield firmly. The rear window is not considered a windshield and any wiper present on the rear window is not an item of inspection.

2. Inspect for and reject if:

- a. Vehicle is not equipped with the number of wipers with which it was originally equipped.
- b. Wiper is inoperative, does not operate freely, or is improperly adjusted.
- c. Wiper blades have damaged, hardened, or badly worn rubber elements.
- d. The portion of the rubber element that contacts the windshield is torn more than one inch on one end or is torn a total of one inch on both ends.
- e. Any part of the rubber element is torn loose from the metal backing or blade base.
- f. Metal parts of wiper blades or arms are damaged or come in contact with the windshield.
- g. Wiper is incapable of adequately cleaning the windshield.
- h. Wiper blades are not making proper contact with windshield.
- i. Wiper controls are not operating properly or are located beyond the driver's reach.

06.20.00 EXAMPLES OF DEFECTIVE EQUIPMENT ON COMMERCIAL VEHICLES

See Annex #5 for some examples of defective equipment frequently encountered during Commercial Motor Vehicle Inspections.