

THE OFFICIAL ASE STUDY GUIDE

ASE Automobile Tests



INCLUDES LIGHT VEHICLE/CNG, EXHAUST SYSTEMS, & AUTO SERVICE CONSULTANT TESTS



National Institute for
**AUTOMOTIVE
SERVICE
EXCELLENCE**

ASE AUTOMOBILE TESTS

Table of Contents

<i>Overview</i>	3–8
<i>Automobile Tests</i>	9–64
• Engine Repair (A1).....	9
• Automatic Transmission/Transaxle (A2).....	15
• Manual Drive Train and Axles (A3)	20
• Suspension and Steering (A4)	26
• Brakes (A5).....	33
• Electrical/Electronic Systems (A6).....	40
• Heating and Air Conditioning (A7)	46
• Engine Performance (A8).....	51
• Light Vehicle Diesel Engines (A9).....	58
<i>Service Consultant Test</i>	65–69
• Automobile Service Consultant (C1).....	65
<i>Alternate Fuels Test</i>	70–74
• Compressed Natural Gas Vehicle (F1)	70
<i>Specialty Tests</i>	75–79
• Exhaust Systems (X1).....	75
<i>Test Prep & Training</i>	80

OVERVIEW

Introduction

The *Official ASE Study Guide of Automobile Tests* is designed to help technicians study for the ASE certification tests. It covers detailed information on the technology found in most of today's automobiles, sport utility vehicles, and light trucks. The specific information about each test, found in the following pages, should help you review the technical knowledge that is covered in the Automobile tests. And if needed, you should find it easier to select additional reference materials that will help you prepare for your test(s).

ASE voluntary certification helps technicians prove their abilities to themselves, to their employers, and to their customers. By passing ASE tests, you will earn the most valuable credential available to automotive technicians. Because the tests are tough, you'll have the satisfaction of proving to yourself that you are among the elite in your profession. What's more, these credentials are recognized throughout the U.S.

Certified technicians promote customer trust and improve the image of the industry. And trust and professionalism are the first steps to a better, more prosperous business.

ASE encourages you to take the tests and to join the proven pros who wear the ASE Blue Seal of Excellence®.

How Do I Become Certified?

There are nine tests in the Automobile Technician certification series. If you pass one or more tests, and have at least two years of hands-on working experience in automotive repair (appropriate training may substitute for up to one year of experience), you will become certified as an ASE Automobile Technician.

If you pass tests A1 through A8 and meet the experience requirement, you will earn the certificate of Master Automobile Technician. Note: Test A9 is not required for Master Automobile Technician status.

You must have passed test A8 to be eligible to take the Advanced Engine Performance Specialist (L1) Test. To take the Light Duty Hybrid/Electric Vehicle Specialist (L3) Test, you must have passed both the A6 and A8 tests.

You will receive your test results at the end of your test appointment. You can review and print them later by logging in to your MyASE account. Results

OVERVIEW (CONTINUED)

will not be given over the phone nor will they be released to anyone without your written permission. If you fail a test, you must wait 30 days from the test date before you can purchase it again.

Certification credentials are valid for five years. This ensures that certified technicians are recognized as being up-to-date in their profession. If it has been almost five years since you passed a test, it is time to register for the corresponding recertification test. Most recertification tests are about half the length of the regular tests.

This *Study Guide* contains Test Specifications, Task Lists, and sample questions for the following ASE tests:

- **Automobile Tests:** Engine Repair (Test A1); Automatic Transmission/Transaxle (Test A2); Manual Drive Train and Axles (Test A3); Suspension and Steering (Test A4); Brakes (Test A5); Electrical/Electronic Systems (Test A6); Heating and Air Conditioning (Test A7); Engine Performance (Test A8); and Light Vehicle Diesel Engines (Test A9)
- **Service Consultant Test:** Automobile Service Consultant (Test C1)
- **Alternate Fuels:** Compressed Natural Gas Vehicle (Test F1)
- **Specialty Tests:** Exhaust Systems (Test X1)

You will become an Undercar Specialist when you pass the XI test and meet the following requirements: you must be currently certified in both A4 and A5 to register for test X1 (regular or recertification).

ASE offers certification in areas including Medium/Heavy Truck, Truck Equipment, School Bus, Transit Bus, Collision Repair/Refinish, Parts Specialist, and Advanced Level specialties. Separate *Study Guides* are available.

For full information on ASE testing as well as downloadable *Study Guides* and other test preparation resources, visit www.ase.com.

Who Writes the Questions?

The questions, written by service industry experts familiar with all aspects of automobile repair, are entirely job-related. They are designed to test the skills that you need to know in servicing automobiles; theoretical knowledge is not covered.

Each question has its roots in an ASE “item-writing” workshop where service representatives from automobile manufacturers (domestic and import), aftermarket parts and equipment manufacturers, working technicians and vocational educators meet to share ideas and translate them into test questions. Each test question written by these experts must survive review by all members of the group. The questions are written to deal with practical problems of diagnosis and repair experienced by technicians in their day-to-day work.

OVERVIEW (CONTINUED)

How Long are the Tests?

ASE Tests 2017		Certification Tests		Recertification Tests	
Test	Name	Number of questions*	Testing time	Number of questions	Testing time
Automobile/Light Truck Tests					
A1	Engine Repair	60*	1¼ hrs.	25	30 min.
A2	Automatic Transmission / Transaxle	60*	1¼ hrs.	25	30 min.
A3	Manual Drive Train and Axles	50*	1 hr.	20	30 min.
A4	Suspension and Steering	50*	1 hr.	20	30 min.
A5	Brakes	55*	1¼ hrs.	23	30 min.
A6	Electrical / Electronic Systems	60*	1½ hrs.	25	45 min.
A7	Heating and Air Conditioning	60*	1¼ hrs.	25	30 min.
A8	Engine Performance	60*	1¼ hrs.	25	45 min.
A9	Light Vehicle Diesel Engines	60*	1¼ hrs.	25	30 min.
Service Consultant Test					
C1	Automobile Service Consultant	60*	1¼ hrs.	25	30 min.
Alternate Fuels Test					
F1	Compressed Natural Gas Vehicles	65*	1½ hrs.	28	45 min.
Specialty Test					
X1	Exhaust Systems	50*	1 hr.	20	30 min.

*** ASE certification tests include 10 research questions that are not counted for score. You will not be told which questions these are, so you should answer every question. No research questions are added to recertification tests. You are eligible to take the recertification test only after you have previously passed the corresponding certification test.**

Next, all questions are pre-tested and quality-checked on a national sample of technicians. Those questions that meet ASE standards of quality and accuracy are included in the scored sections of the tests; the “rejects” are sent back to the drawing board or discarded altogether.

How Do I Prepare for the ASE Tests?

Become familiar with test content and question formats.

The Test Specifications in this booklet contain a description of the content covered by each test. The Task Lists describe the actual work performed by technicians in each specialty area. Together, these form a “blueprint” for writing and assembling the ASE tests.

Please note that each question on the test is related to a particular task or set of tasks in the task list. Therefore, review the task list, thinking about whether you know how to perform each task listed.

All questions are multiple-choice. The sample questions in this *Study Guide* are examples of the five types of questions on the test. Note the different instructions for each question type.

Be sure to read each question carefully so that you understand exactly what is being asked. *Each question tests a specific diagnostic or repair problem and has only **one** correct answer.*

To summarize, we suggest the following steps be taken:

Step 1. Carefully read the content list for each test you will attempt.

Step 2. Study the task list for each area.

Step 3. Go over the sample questions to become familiar with each question type. *This is very important!*

Step 4. Review steps 1 through 3 and identify the skill areas where you need additional study.

Getting Started

Registration information is available on the ASE website at www.ase.com. This site will provide you with the dates and locations that testing is available and other important information, including an electronic version of this and all other ASE *Study Guides*.

While on the ASE website, take the time to create your own myASE account (if you do not already have one), which will allow you to register for tests, make your own test appointments, and have direct access to all your personal ASE certification information. And as always, if you have questions that www.ase.com does not answer, contact our helpful customer service staff at asehelp@ase.com or 1-800-390-6789.

OVERVIEW (CONTINUED)

At the Test Center—Some Tips

Try to be well rested on exam day. Arrive early enough to park and find the Test Center office. Late arrivals may be turned away by Test Center staff. If you cannot take a test because you are late, you will forfeit your test fees.

Bring your Admission Ticket and government-issued photo ID with you. Books, calculators, and other reference materials will not be permitted in the test room. You will be assigned a locker to store all your personal items. No electronic devices (including cell phones) are allowed in the test room. Most test centers have airport-level security procedures for all candidates, so be prepared for “wandering” or other security checks.

You will receive scratch paper and pencils, and if you are taking an Advanced Level L1 or L2 test, a Composite Vehicle Reference booklet. After you are seated, the supervisor will explain how to use the computer and mouse. Each test appointment begins with a short tutorial on the operation of the computer-based test. You can also preview the system online at www.ase.com/cbt before you arrive at the Test Center.

Each test has a specific time limit, as listed in the chart on page 5. As you take each test, the computer screen will continuously display the amount of time left. If you finish early, you may either review your answers or end the test and continue to the next test (if your appointment includes multiple tests). Once you submit a test for scoring, you cannot go back and review it. If you are taking several tests and need a break, the best time to take it is at the title screen of one of the tests, **before** you click “Begin.” You can take a break after this if necessary, but the test clock will continue to run.

If a question is difficult, mark the answer that you think is correct and flag the question using the on-screen button. Then go on to the next question. When you have finished the test, you may have time to go back to the flagged questions. Your score is based on the number of correct answers that you give, so you should try to answer every question.

When you finish your last test, you will be given a short customer satisfaction survey. After you complete the survey, inform the staff and receive your score reports.

Bring--

- ✓ Admission Ticket
- ✓ Current Gov't. Issued Photo ID

Leave in locker--

- ✓ Books
- ✓ Calculator
- ✓ Coat
- ✓ Cell Phone
- ✓ Wallet
- ✓ Keys

Test Content and Sample Questions

The following material is designed to help technicians prepare for the ASE certification tests.

Each section begins with the Test Specifications, which will list the main categories covered and the number of test questions, as well as percentage of the test devoted to each topic.

The Task List describes the work activities a technician should be able to perform. This list was developed by working technicians and technical experts from across the country and will provide a valuable checklist telling you what to study for the test.

Note that the number of tasks in the list does not equal the number of questions on the test. Some tasks are complex and broad in scope and may be covered by several questions. Other tasks are simple and narrow in scope and one question may cover several tasks. The main goal in listing the tasks is to describe accurately what is done on the job, not to match each task to a particular test question. In other words, every question will relate to at least one task, but not every task will be covered on the test.

Sample questions follow the task list. Although these questions will not appear on tests, they are in the same format as actual test questions. Different types of multiple-choice questions are used on the ASE tests. Note the different instructions for some questions. ■

TEST SPECIFICATIONS AND TASK LIST

ENGINE REPAIR (TEST A1)

Content Area	Questions in Test	Percentage of Test
A. General Engine Diagnosis	15	30%
B. Cylinder Head and Valve Train Diagnosis and Repair	10	20%
C. Engine Block Diagnosis and Repair	10	20%
D. Lubrication and Cooling Systems Diagnosis and Repair	8	16%
E. Fuel, Electrical, Ignition, and Exhaust Systems Inspection and Service	7	14%
Total	50	100%

A. General Engine Diagnosis (15 questions)

1. Verify driver's complaint and/or road test vehicle; determine necessary action.
2. Determine if no-crank, cranks but will not start, or hard starting condition is an engine mechanical problem, or is caused by another vehicle subsystem.
3. Inspect engine assembly for fuel, oil, coolant, and other leaks; determine necessary action.
4. Isolate engine noises and vibrations; determine necessary action.
5. Diagnose the cause of excessive oil consumption, coolant consumption, unusual engine exhaust color, and odor; determine necessary action.
6. Perform engine vacuum tests; determine necessary action.
7. Perform cylinder power balance tests; determine necessary action.
8. Perform cylinder cranking compression tests; determine necessary action.
9. Perform cylinder leakage tests; determine necessary action.

B. Cylinder Head and Valve Train Diagnosis and Repair (10 questions)

1. Remove cylinder heads, disassemble, clean, and prepare for inspection.
2. Visually inspect cylinder heads for cracks, warpage, corrosion, leakage, and the condition of passages; determine needed repairs.
3. Inspect and repair damaged threads where allowed; install core and gallery plugs.
4. Inspect, test, and verify valve springs for squareness, pressure, and free height comparison; replace as necessary.
5. Inspect valve spring retainers, rotators, locks/keepers, and lock grooves.
6. Replace valve stem seals.
7. Inspect valve guides for wear; check valve stem-to-guide clearance; determine needed repairs.

A1 TASK LIST (CONTINUED)

8. Inspect valves and valve seats; determine needed repairs.
9. Check valve spring installed (assembled) height and valve stem height; determine needed repairs.
10. Inspect pushrods, rocker arms, rocker arm pivots, and shafts for wear, bending, cracks, looseness, and blocked oil passages; repair or replace as required.
11. Inspect and replace hydraulic or mechanical lifters/lash adjusters.
12. Adjust valves on engines with mechanical or hydraulic lifters.
13. Inspect camshaft(s) (includes checking drive gear wear and backlash, end play, sprocket and chain wear, overhead cam drive sprocket(s), drive belt(s), belt tension, tensioners, camshaft reluctor ring/tone-wheel, and variable valve timing components); replace as necessary.
14. Inspect and measure camshaft journals and lobes; measure camshaft lift.
15. Inspect and measure camshaft bore for wear, damage, out-of-round, and alignment; determine needed repairs.
16. Inspect valve timing; time camshaft(s) to crankshaft.
17. Inspect cylinder head mating surface condition and finish, reassemble and install gasket(s) and cylinder head(s); replace/torque bolts according to manufacturers' procedures.

C. Engine Block Diagnosis and Repair (10 questions)

1. Remove and disassemble engine block; clean and prepare components for inspection and reassembly.
2. Visually inspect engine block for cracks, corrosion, the condition of passages, core and gallery plug hole condition, surface warpage, and surface finish and condition; inspect piston oil cooling nozzle/jets for damage, improper alignment and restriction; determine necessary action.
3. Inspect and repair damaged threads where allowed; install core and gallery plugs.
4. Clean and inspect cylinder walls; measure cylinder bore; determine need for further action.
5. Inspect crankshaft for end play, journal damage, keyway damage, thrust flange and sealing surface condition, and visual surface cracks; check oil passage condition; measure journal wear; check crankshaft reluctor ring/tone wheel (where applicable); determine necessary action.
6. Inspect main bearing wear patterns; inspect and measure main bearing bores and cap alignment; mark caps for location and direction; clean and inspect crank girdle (bed plate/ladder) where applicable.
7. Install main bearings and crankshaft; check bearing clearances and end play; inspect, replace, and torque bolts according to manufacturers' procedures.
8. Inspect camshaft bearings for excessive wear and alignment; replace bearings if necessary; install camshaft, timing chain and gears; check end play.
9. Inspect auxiliary (balance, intermediate, idler, counterbalance, or silencer) shaft(s), drive(s)/gear(s), and support bearings for damage and wear; time balance shaft to crankshaft; determine necessary action.
10. Inspect, measure, service, or replace pistons and piston/wrist pins; identify piston and bearing wear patterns caused by connecting rod alignment problems; determine necessary action.
11. Inspect connecting rods and bearings for damage, bore condition, and pin fit; mark caps for location and direction; determine necessary action.

A1 TASK LIST (CONTINUED)

12. Inspect, measure, and install or replace piston rings; assemble piston and connecting rod; install piston/rod assembly; check bearing clearance and sideplay; install connecting rod bearings; inspect, replace, and torque fasteners according to manufacturers' procedures.
13. Inspect, reinstall, or replace crankshaft vibration damper/harmonic balancer (includes dual-mass damper).
14. Inspect crankshaft flange and flywheel mating surfaces; inspect and replace crankshaft pilot bearing/bushing (if applicable); inspect flywheel/flexplate and flywheel ring gear for cracks and wear (includes dual-mass flywheel); measure flywheel runout; determine necessary action.
15. Inspect and replace pans and covers.
16. Assemble the engine using gaskets, seals, and formed-in-place (tube-applied) sealants, and thread sealers, according to manufacturers' specifications; reinstall engine.

D. Lubrication and Cooling Systems Diagnosis and Repair (8 questions)

1. Diagnose engine lubrication system problems; perform oil pressure tests; determine necessary action.
2. Disassemble and inspect oil pump (includes gears, rotors, housing, and pick-up assembly); measure oil pump clearance; inspect pressure relief devices and pump drive; determine necessary action.
3. Inspect, test, and flush or replace internal and external engine oil coolers.
4. Fill crankcase with oil and install engine oil filter.
5. Perform cooling system pressure tests; perform coolant dye test; determine necessary action.
6. Inspect and test radiator, heater core, pressure cap, and coolant recovery system; replace as required.
7. Inspect, replace, and adjust drive belt(s), tensioner(s), and pulleys.
8. Inspect and replace engine cooling system and heater system hoses, pipes and fittings.
9. Inspect, test, and replace thermostat, coolant by-pass, and thermostat housing.
10. Inspect and replace water pump.
11. Inspect and test coolant; drain, flush, and refill cooling system with recommended coolant; bleed air as required.
12. Inspect and test fan (both electrical and mechanical), fan clutch, fan shroud, air dams, and cooling fan electrical circuits; repair or replace as required.
13. Verify proper operation of engine related warning indicators.

E. Fuel, Electrical, Ignition, and Exhaust Systems Inspection and Service (7 questions)

1. Inspect, clean or replace fuel injection system components, intake manifold, and gaskets.
2. Inspect, service or replace air filters, filter housings, and intake ductwork.
3. Inspect turbocharger/supercharger systems; determine necessary action.
4. Test engine cranking system; determine needed repairs.
5. Inspect and test crankcase ventilation system components; replace as necessary.
6. Inspect and test ignition system components; replace as necessary; verify timing.
7. Inspect and diagnose exhaust system; determine needed repairs. ■

SAMPLE QUESTIONS

ENGINE REPAIR (TEST A1)

1. Technician A says that part X shown is used to rotate the valve spring. Technician B says that part X shown is used to correct installed spring height.

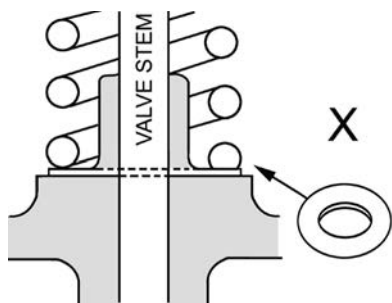

Who is right?

- (A) A only
 - * (B) B only
 - (C) Both A and B
 - (D) Neither A nor B
2. A compression test shows that one cylinder is too low. A leakage test on that cylinder shows that there is too much leakage. During the test, air could be heard coming from the tail pipe. Which of these could be the cause?
- (A) Broken piston rings
 - (B) A blown head gasket
 - (C) A leaking exhaust manifold gasket
 - * (D) An exhaust valve not seating
3. Technician A says that main bearing oil clearance can be checked with plastigage. Technician B says that main bearing oil clearance can be checked with a feeler gauge. Who is right?
- * (A) A only
 - (B) B only
 - (C) Both A and B
 - (D) Neither A nor B
4. An engine is using too much oil. Technician A says that worn valve guides could be the cause. Technician B says that tapered cylinder walls could be the cause. Who is right?
- (A) A only
 - (B) B only
 - * (C) Both A and B
 - (D) Neither A nor B

A1 SAMPLE QUESTIONS (CONTINUED)

5. A compression test has been made on an in-line 4-cylinder engine. Cylinders 2 and 3 have readings of 10 psi. Cylinder 1 has a reading of 140 psi and cylinder 4 has a reading of 145 psi. Technician A says that these readings could be caused by a blown head gasket. Technician B says that these readings could be caused by wrong valve timing. Who is right?
- * (A) A only
 - (B) B only
 - (C) Both A and B
 - (D) Neither A nor B

6. To determine piston-to-cylinder wall clearance, the diameter of the piston shown should be measured at:

- (A) W.
- (B) X.
- * (C) Y.
- (D) Z.

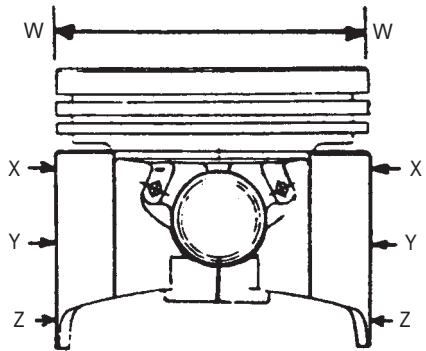

7. Which of these would most likely cause a fuel-injected engine to have low fuel pressure?
- * (A) A clogged fuel filter
 - (B) A clogged fuel injector
 - (C) A restricted fuel return line
 - (D) A stuck-closed fuel pressure regulator

A1 SAMPLE QUESTIONS (CONTINUED)

8. Technician A says that the setup shown can be used to check cylinder taper. Technician B says that the setup shown can be used to check cylinder out-of-round. Who is right?

- (A) A only
- (B) B only
- * (C) Both A and B
- (D) Neither A nor B

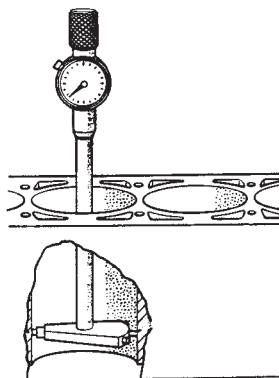

9. The pressure and volume tests on a mechanical fuel pump are both below specs. Technician A says that an air leak in the fuel line between the tank and pump could be the cause. Technician B says that a plugged fuel tank pick up filter could be the cause. Who is right?

- (A) A only
- (B) B only
- * (C) Both A and B
- (D) Neither A nor B

This question contains the word LEAST. Read the question carefully before choosing your answer.

10. The LEAST likely cause of a bent push rod is:
- (A) excessive engine rpm.
 - (B) a sticking valve.
 - * (C) excessive valve guide clearance.
 - (D) a worn rocker arm stud.

TEST SPECIFICATIONS AND TASK LIST

AUTOMATIC TRANSMISSION/TRANSAXLE (TEST A2)

Content Area	Questions in Test	Percentage of Test
A. General Transmission/Transaxle Diagnosis	25	50%
1. Mechanical/Hydraulic Systems (11)		
2. Electronic Systems (14)		
B. In-Vehicle Transmission/Transaxle Maintenance and Repair	12	24%
C. Off-Vehicle Transmission/Transaxle Repair	13	26%
1. Removal and Installation (4)		
2. Disassembly and Assembly (5)		
3. Friction and Reaction Units (4)		
Total	50	100%

A. General Transmission/Transaxle Diagnosis (25 questions)

1. Mechanical/Hydraulic Systems (11 questions)

1. Road test the vehicle to verify mechanical/hydraulic system problems based on driver's concern; determine necessary action.
2. Diagnose noise, vibration, harshness, and shift quality problems; determine necessary action.
3. Diagnose fluid loss, type, level, and condition problems; determine necessary action.
4. Perform pressure tests; determine necessary action.
5. Perform stall tests; determine necessary action.
6. Perform torque converter clutch (lock-up converter) mechanical/hydraulic system tests; determine necessary action.

2. Electronic Systems (14 questions)

1. Road test the vehicle to verify electronic system problems based on driver's concern; determine necessary action.
2. Perform pressure tests on transmissions equipped with electronic pressure control; determine necessary action.
3. Perform torque converter clutch (lock up converter) electronic system tests; determine necessary action.
4. Diagnose electronic transmission control systems using appropriate test equipment, service information, technical service bulletins, and schematics; diagnose shorts, grounds, opens, and resistance problems in electrical/electronic circuits; determine necessary action.

A2 TASK LIST (CONTINUED)

5. Verify proper operation of charging system; check battery, connections, and power/ground circuits.
6. Differentiate between engine performance, or other vehicle systems, and transmission/transaxle related problems; determine necessary action.
7. Diagnose shift quality concerns resulting from problems in the electronic transmission control system; determine necessary action.

B. In-Vehicle Transmission/Transaxle Maintenance and Repair (12 questions)

1. Inspect, adjust, and replace manual valve shift linkage, transmission range sensor/switch, and park/neutral position switch (inhibitor/neutral safety switch).
2. Inspect, adjust, and replace cables or linkages for the throttle valve (TV) and accelerator pedal.
3. Inspect and replace external seals and gaskets.
4. Inspect and replace driveshaft yoke, drive axle joints, and bushings, and seals.
5. Check condition and operation of engine cooling system; inspect transmission cooler, lines and fittings.
6. Inspect valve body mating surfaces, bores, valves, springs, sleeves, retainers, brackets, check balls, screens, spacer plates, and gaskets; replace as necessary.
7. Torque valve body fasteners to specification.
8. Inspect accumulator and servo bores, pistons, seals, pins/pin bores, springs, and retainers; repair or replace as necessary.
9. Inspect, test, adjust, repair, or replace electrical/electronic components and circuits including control modules, solenoids, sensors, relays, terminals, connectors, switches, and harnesses.
10. Inspect, replace, and/or align power train mounts.
11. Replace fluid and filter(s); verify proper fluid level and type (for transmissions with, or without, a dipstick).

C. Off-Vehicle Transmission/Transaxle Repair (13 questions)

1. Removal and Installation (4 questions)

1. Remove and install transmission/transaxle; inspect engine core plugs, rear crankshaft seal, transmission dowel pins, dowel pin holes, and mating surfaces.
2. Inspect converter flex (drive) plate, converter attaching bolts, converter pilot, crankshaft pilot bore, converter pump drive surfaces.
3. Install torque converter and establish correct converter-to-pump engagement; inspect converter free movement for pilot engagement during transmission installation.
4. Inspect, test, flush or replace transmission fluid cooler.
5. Inspect brackets, wiring harnesses, fuel lines, heat shields, inspection covers, and related components for proper routing and installation.
6. Perform module coding and/or programming (including adaptive learning reset); road test to confirm proper operation.

2. Disassembly and Assembly (5 questions)

1. Disassemble, clean, and inspect transmission case, sub-assemblies, mating surfaces, and thread condition.
2. Inspect and measure fluid pump components; replace as necessary.

A2 TASK LIST (CONTINUED)

3. Check bearing preload; determine needed service.
4. Check end play; inspect, measure, and replace thrust washers and bearings as needed.
5. Inspect shafts; replace as necessary.
6. Inspect fluid delivery circuit, including seal rings, ring grooves, sealing surface areas, feed pipes, orifices, and encapsulated check valves (balls).
7. Inspect bushings; replace as necessary.
8. Inspect and measure components of the planetary gear assembly; replace as necessary.
9. Inspect case bores, passages, bushings, vents, mating surfaces, and dowel pins; repair or replace as necessary.
10. Inspect valve body mating surfaces, bores, valves, solenoids, springs, sleeves, retainers, brackets, check balls, screens, spacer plates, and gaskets; replace as necessary.
11. Inspect transaxle drive chains, sprockets, gears, bearings, and bushings; replace as necessary.
12. Inspect and measure transaxle final drive components; repair, replace and/or adjust as necessary.
13. Assemble after repair.

3. Friction and Reaction Units (4 questions)

1. Inspect components of the hydraulic clutch pack assembly; replace as necessary.
2. Measure clutch pack clearance; adjust as necessary.
3. Air test the operation of clutch and servo assemblies.
4. Inspect components of one way clutch assemblies; replace as necessary.
5. Inspect bands and drums (housings/cylinders); replace and/or adjust as necessary. ■

SAMPLE QUESTIONS

AUTOMATIC TRANSMISSION/TRANSAXLE (TEST A2)

1. An automatic transmission does not hold in PARK.
Technician A says that misadjusted shift linkage could be the cause.
Technician B says that a roller clutch installed backwards could be the cause.
Who is right?

* (A) A only
(B) B only
(C) Both A and B
(D) Neither A nor B

2. A vehicle with an automatic transaxle and a properly tuned engine accelerates poorly from a stop. Acceleration is normal above 35 mph. Which of these could be the cause?

(A) A worn front pump
* (B) A failed torque converter
(C) A worn planetary gear set
(D) A low fluid level

3. The transmission slips when cold. Which of these could be the cause?

(A) A shorted low/reverse pressure switch
(B) Line pressure is at maximum in 1st gear
(C) A disconnected line pressure sensor
* (D) Low line pressure

4. The automatic transaxle upshifts harshly during normal acceleration. The cause could be a failed:

(A) oxygen sensor.
(B) idle air control valve.
* (C) throttle position sensor.
(D) intake air temperature sensor.

A2 SAMPLE QUESTIONS (CONTINUED)

5. With the transmission pan removed, the best way to pin-point an oil pressure leak is to:
- (A) check the filter pick-up tube seal.
 - (B) check the line pressure.
 - (C) remove and check the valve body.
 - * (D) perform an air pressure test.

6. The tool in the setup shown is being used to remove the:
- * (A) pump bushing.
 - (B) pump seal.
 - (C) stator support.
 - (D) stator seal.

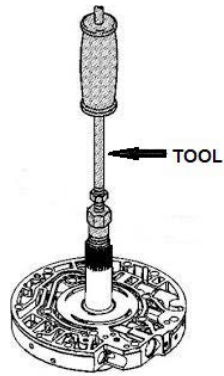

7. A vehicle with an OBD II computer system has stored transmission trouble codes. After repairs are completed, the trouble codes should be cleared by:
- (A) disconnecting the battery.
 - (B) disconnecting the TCM.
 - * (C) using a scan tool.
 - (D) removing the TCM fuse.

This question contains the word EXCEPT. Read the question carefully before choosing your answer.

8. Too much automatic transmission shaft end play could be caused by any of these EXCEPT a worn:
- * (A) clutch.
 - (B) selective washer.
 - (C) transmission case.
 - (D) planetary carrier.

TEST SPECIFICATIONS AND TASK LIST

MANUAL DRIVE TRAIN AND AXLES (TEST A3)

Content Area	Questions in Test	Percentage of Test
A. Clutch Diagnosis and Repair	6	16%
B. Transmission Diagnosis and Repair	7	17%
C. Transaxle Diagnosis and Repair	7	17%
D. Drive Shaft/Half-Shaft and Universal Joint/Constant Velocity (CV) Joint Diagnosis and Repair (Front and Rear Wheel Drive)	5	13%
E. Drive Axle Diagnosis and Repair	7	17%
1. Ring and Pinion Gears (3)		
2. Differential Case/Carrier Assembly (2)		
3. Limited Slip/Locking Differential (1)		
4. Axle Shafts and Housing(1)		
F. Four-Wheel Drive/All-Wheel Drive Component Diagnosis and Repair	8	20%
Total	40	100%

A. Clutch Diagnosis and Repair (6 questions)

1. Diagnose clutch noise, binding, slippage, pulsation, chatter, pedal feel/effort, and release problems; determine needed repairs.
2. Inspect, adjust, and replace clutch pedal linkage, brackets, bushings, pivots, springs, and electrical switches.
3. Inspect, adjust, replace, and bleed hydraulic clutch slave/release cylinder, master cylinder, lines, and hoses; clean and flush hydraulic system; refill with proper fluid.
4. Inspect, adjust, and replace release (throw-out) bearing, bearing retainer, lever, and pivot.
5. Inspect and replace clutch disc and pressure plate assembly; inspect input shaft pilot and splines.
6. Inspect pilot bearing/bushing inner and outer bores; inspect and replace pilot bearing/bushing.
7. Inspect and measure flywheel and ring gear; inspect dual-mass flywheel where required; repair or replace as necessary.
8. Inspect engine block, clutch (bell) housing, transmission case mating surfaces, and alignment dowels; inspect engine core plugs, rear main engine seal, and other sources of fluid contamination; determine needed repairs.

A3 TASK LIST (CONTINUED)

9. Measure flywheel surface runout and crankshaft end play; determine needed repairs.
10. Inspect, replace, and align powertrain mounts.

B. Transmission Diagnosis and Repair (7 questions)

1. Diagnose transmission noise, difficult shifting, gear clash, jumping out of gear, fluid condition and type, and fluid leakage problems; determine needed repairs.
2. Inspect, adjust, lubricate and replace transmission external shift assemblies, linkages, brackets, bushings/grommets, cables, pivots, and levers.
3. Inspect and replace transmission gaskets, sealants, seals, and fasteners; inspect sealing surfaces.
4. Remove and replace transmission; inspect transmission mounts.
5. Disassemble and clean transmission components; reassemble transmission.
6. Inspect, repair, and/or replace transmission shift cover and internal shift forks, bushings, bearings, levers, shafts, sleeves, detent mechanisms, interlocks, and springs.
7. Inspect and replace input (clutch) shaft, bearings, and retainers.
8. Inspect and replace output (main) shaft, gears, thrust washers, bearings, and retainers/snap rings; measure clearance and end play.
9. Inspect and replace synchronizer hub, sleeve, keys (inserts), springs, and blocking (synchronizing) rings/mechanisms; measure blocking ring clearance.
10. Inspect and replace countershaft, counter (cluster) gear, bearings, thrust washers, and retainers/snap rings.
11. Inspect and replace reverse idler gear, shaft, bearings/bushings, thrust washers, and retainers/snap rings.
12. Measure and adjust bearing preload or end play (shim/spacer selection procedure).
13. Inspect, repair, and replace extension housing and transmission case mating surfaces, bores, dowels, bushings, and vents.
14. Inspect and replace transmission components related to speedometer operation.
15. Inspect, test, and replace transmission sensors, actuators, and switches.
16. Inspect lubrication systems.
17. Check fluid level; refill with proper fluid.

C. Transaxle Diagnosis and Repair (7 questions)

1. Diagnose transaxle noise, difficult shifting, gear clash, jumping out of gear, fluid condition and type, and fluid leakage problems; determine needed repairs.
2. Inspect, adjust, lubricate and replace transaxle external shift assemblies, linkages, brackets, bushings/grommets, cables, pivots, and levers.
3. Inspect and replace transaxle gaskets, sealants, seals, and fasteners; inspect sealing surfaces.
4. Remove and replace transaxle; inspect, replace, and align transaxle mounts and subframe/cradle assembly.
5. Disassemble and clean transaxle components; reassemble transaxle.
6. Inspect, repair, and/or replace transaxle shift cover and internal shift forks, levers, bushings, shafts, sleeves, detent mechanisms, interlocks, and springs.
7. Inspect and replace input (clutch) shaft and output (main) shaft, gears, thrust washers, bearings, and retainers/snap rings.

A3 TASK LIST (CONTINUED)

8. Inspect and replace synchronizer hub, sleeve, keys (inserts), springs, and blocking (synchronizing) rings; measure blocking ring clearance.
9. Inspect and replace reverse idler gear, shaft, bearings/bushings, thrust washers, and retainers/snap rings.
10. Inspect, repair, and/or replace transaxle case mating surfaces, bores, dowels, bushings, bearings, and vents.
11. Inspect and replace transaxle components related to speedometer operation.
12. Inspect, test, and replace transaxle sensors, actuators, and switches.
13. Diagnose differential assembly noise and wear; determine needed repairs.
14. Remove and replace differential final drive assembly.
15. Inspect, measure, adjust and replace differential pinion (spider) gears, shaft, side gears, thrust washers, side bearings, and case/carrier.
16. Diagnose limited slip differential noise, slippage, and chatter problems; determine needed repairs.
17. Measure and adjust shaft and differential bearing preload and end play (shim/spacer selection procedure).
18. Inspect lubrication systems.
19. Check fluid level; refill with proper fluid.

D. Drive Shaft/Half-Shaft and Universal Joint/Constant Velocity (CV) Joint Diagnosis and Repair (Front and Rear Wheel Drive) (5 questions)

1. Diagnose drive/half shaft and universal/CV joint noise and vibration problems; determine needed repairs.
2. Inspect, service, and replace shafts, yokes, boots, and universal/CV joints; verify proper phasing.
3. Inspect, service, and replace center support and intermediate shaft bearings.
4. Check and correct drive/propeller shaft balance.
5. Measure drive shaft runout.
6. Measure and adjust drive shaft working angles.
7. Diagnose, inspect, service, and replace wheel bearings, seals, and hubs.

E. Drive Axle Diagnosis and Repair (7 questions)

1. Ring and Pinion Gears (3 questions)

1. Diagnose noise, vibration, and fluid leakage problems; determine needed repairs.
2. Inspect and replace companion flange, yoke, and pinion seal; measure companion flange runout.
3. Measure ring gear runout; determine needed repairs.
4. Inspect and replace ring and pinion gear set, collapsible spacers/sleeves, shims, and bearings.
5. Measure and adjust drive pinion depth.
6. Measure and adjust drive pinion bearing preload (collapsible spacersleeve or shim type).
7. Measure and adjust differential (side) bearing preload, and ring and pinion backlash (threaded adjuster or shim type).
8. Perform ring and pinion tooth contact pattern checks; determine needed adjustments.

A3 TASK LIST (CONTINUED)

2. Differential Case/Carrier Assembly (2 questions)

1. Diagnose differential assembly noise and vibration problems; determine needed repairs.
2. Remove and replace differential assembly.
3. Inspect, measure, adjust and replace differential pinion (spider) gears, shaft, side gears, thrust washers, side bearings, and case/carrier.
4. Measure differential case/carrier runout; determine needed repairs.

3. Limited Slip/Locking Differential (1 question)

1. Diagnose limited slip differential noise, slippage, and chatter problems; determine needed repairs.
2. Inspect, drain, and refill with proper lubricant.
3. Inspect, adjust, repair or replace limited slip or locking assembly components.

4. Axle Shafts and Housing (1 question)

1. Diagnose rear axle shaft noise, vibration, and fluid leakage problems; determine needed repairs.
2. Inspect and replace rear axle shaft wheel studs.
3. Remove, inspect, adjust, and/or replace rear axle shafts, splines, seals, bearings, and retainers.
4. Measure rear axle flange runout and shaft end play; determine needed repairs.
5. Inspect axle housing and vent.

F. Four-Wheel Drive/All-Wheel Drive Component Diagnosis and Repair (8 questions)

1. Diagnose drive assembly noise, vibration, leakage and steering problems; determine needed repairs.
2. Inspect, adjust, and repair transfer case manual shifting mechanisms, bushings, mounts, levers, and brackets.
3. Remove and replace transfer case.
4. Disassemble transfer case; clean and inspect internal transfer case components; determine needed repairs.
5. Reassemble transfer case.
6. Check transfer case fluid level; drain and refill with proper fluid.
7. Inspect, service, and replace drive/propeller shaft and universal/CV joints.
8. Inspect, service, and replace drive axle universal/CV joints and drive/half-shafts.
9. Inspect, service, and replace wheel bearings, seals, and hubs.
10. Check transfer case and axle seals and all vents.
11. Diagnose drive system actuation and engagement concerns; repair or replace components as necessary (including: viscous, hydraulic, magnetic, mechanical, vacuum, and electrical/electronic).
12. Inspect tires for condition and matching circumference; verify proper size for vehicle application. ■

SAMPLE QUESTIONS

MANUAL DRIVE TRAIN AND AXLES (TEST A3)

1. A manual transmission slips out of high gear. Which of these could be the cause?
 - (A) Worn blocking rings
 - * (B) Too much main shaft end play
 - (C) Broken synchronizer keys
 - (D) Worn shifter interlocks

2. In a vehicle with a single-plate clutch, loss of free pedal can be caused by:
 - (A) a worn release bearing.
 - (B) a broken clutch linkage.
 - * (C) a worn clutch disc facing.
 - (D) weak pressure plate springs.

3. A four-speed, fully synchronized transmission has a clunking or knocking noise in first and reverse only.

Technician A says that a broken tooth on the clutch (input) gear could be the cause.

Technician B says that a broken tooth on the counter (cluster) gear could be the cause.

Who is right?

 - (A) A only
 - * (B) B only
 - (C) Both A and B
 - (D) Neither A nor B

4. A manual transaxle makes a clunking noise on acceleration and on deceleration.

Technician A says that a loose differential case pinion shaft could be the cause. Technician B says that worn CV joints could be the cause.

Who is right?

 - (A) A only
 - (B) B only
 - * (C) Both A and B
 - (D) Neither A nor B

A3 SAMPLE QUESTIONS (CONTINUED)

5. Technician A says that the set-up shown can be used to check pinion-to-ring gear preload. Technician B says that the set-up shown can be used to check pinion flange nut torque. Who is right?

- (A) A only
- (B) B only
- (C) Both A and B
- * (D) Neither A nor B

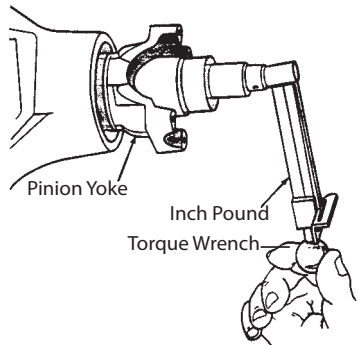

6. Which of these is the technician measuring in the illustration shown?

- * (A) Side gear clearance
- (B) Ring gear runout
- (C) Pinion depth
- (D) Bearing preload

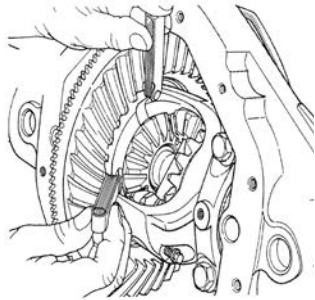

7. A four-wheel drive vehicle vibrates while the front axle is engaged. Technician A says that a failed front axle shaft CV joint could be the cause. Technician B says that different front and rear tire diameters could be the cause. Who is right?

- (A) A only
- (B) B only
- * (C) Both A and B
- (D) Neither A nor B

This question contains the word EXCEPT. Read the question carefully before choosing your answer.

8. The clutch does not release fully when the pedal is pushed to the floor. Any of these could be the cause EXCEPT:
- * (A) weak pressure plate springs.
 - (B) too much free pedal travel.
 - (C) a warped clutch disc.
 - (D) a seized pilot bearing.

TEST SPECIFICATIONS AND TASK LIST

SUSPENSION AND STEERING (TEST A4)

Content Area	Questions in Test	Percentage of Test
A. Steering Systems Diagnosis and Repair	12	30%
B. Suspension Systems Diagnosis and Repair	12	30%
C. Wheel Alignment Diagnosis, Adjustment, and Repair	11	28%
D. Wheel and Tire Diagnosis and Service	5	12%
Total	40	100%

A. Steering Systems Diagnosis and Repair (12 questions)

► Steering Columns

1. Diagnose steering column noises and steering effort concerns (including manual and electronic tilt and telescoping mechanisms); determine needed repairs.
2. Inspect and replace steering column, steering shaft U-joint(s), flexible coupling(s), collapsible columns, and steering wheels (including steering wheels and columns equipped with air bags and/or other steering wheel/column mounted controls, sensors, and components).
3. Disarm, enable, and properly handle airbag system components during vehicle service following manufacturers' procedures.
4. Diagnose, inspect, adjust, repair or replace components (including motors, sensors, switches, actuators, harnesses, and control units) of steering column-mounted, electronically controlled, hydraulically and/or electrically assisted steering systems; initialize systems as required.

► Steering Units

5. Diagnose steering gear (non-rack and pinion type) noises, binding, vibration, freeplay, steering effort, steering pull (lead), and leakage concerns; determine needed repairs.
6. Diagnose rack and pinion steering gear noises, binding, vibration, freeplay, steering effort, steering pull (lead), and leakage concerns; determine needed repairs.
7. Inspect power steering fluid level and condition; determine fluid type and adjust fluid level in accordance with vehicle manufacturers' recommendations.
8. Inspect, adjust, align, and replace power steering pump belt(s), tensioners and pulleys.

A4 TASK LIST (CONTINUED)

9. Diagnose power steering pump noises, vibration, and fluid leakage; determine needed repairs.
10. Remove and replace power steering pump; inspect pump mounting and attaching brackets; remove and replace power steering pump pulley; transfer related components.
11. Perform power steering system pressure and flow tests; determine needed repairs.
12. Inspect and replace power steering hoses, fittings, O-rings, coolers, and filters.
13. Remove and replace steering gear (non-rack and pinion type).
14. Remove and replace rack and pinion steering gear; inspect and replace mounting bushings and brackets.
15. Adjust steering gear (non-rack and pinion type) worm bearing preload and sector lash.
16. Inspect and replace steering gear (non-rack and pinion type) seals and gaskets.
17. Adjust rack and pinion steering gear.
18. Inspect and replace rack and pinion steering gear bellows/boots.
19. Flush, fill, and bleed power steering system.
20. Diagnose, inspect, repair or replace components of variable-assist and/or variable-ratio steering systems.
21. Diagnose, inspect, adjust, repair or replace components (including motors, sensors, switches, actuators, harnesses, and control units) of rack-mounted, electronically controlled, hydraulically and/or electrically assisted steering systems; initialize systems as required.

► Steering Linkage

22. Inspect and adjust (where applicable) front and rear steering linkage geometry (including parallelism and vehicle ride height).
23. Inspect and replace pitman arm.
24. Inspect and replace center link (relay rod/drag link/intermediate rod).
25. Inspect, adjust (where applicable), and replace idler arm(s) and mountings.
26. Inspect, replace, and adjust tie rods, tie rod sleeves/adjusters, clamps, and tie rod ends (sockets/bushings).
27. Inspect and replace steering linkage damper(s).

B. Suspension Systems Diagnosis and Repair (12 questions)

► Front Suspensions

1. Diagnose front suspension system noises, handling, ride height and ride quality concerns; determine needed repairs.
2. Inspect and replace upper and lower control arms, bushings, and shafts.
3. Inspect and replace rebound and jounce bumpers.
4. Inspect, adjust, and replace track bar, strut rods/radius arms, and related mounts/bushings.
5. Inspect and replace upper and lower ball joints (with or without wear indicators).
6. Inspect non-independent front axle assembly for damage and misalignment.
7. Inspect and replace front steering knuckle/spindle assemblies and steering arms.
8. Inspect and replace front suspension system coil springs and spring insulators (silencers).

A4 TASK LIST (CONTINUED)

9. Inspect and replace front suspension system leaf spring(s), leaf spring insulators (silencers), shackles, brackets, bushings, center pins/bolts, and mounts.
10. Inspect, replace, and adjust front suspension system torsion bars and mounts.
11. Inspect and replace front stabilizer bar (sway bar) bushings, brackets, and links.
12. Inspect and replace front strut cartridge or assembly.
13. Inspect and replace front strut bearing(s) and mount(s).
14. Inspect and replace shock absorbers, mounts, and bushings.
15. Diagnose and service front wheel bearings/hub assemblies.
16. Diagnose, inspect, adjust, repair or replace components (including sensors, switches, actuators, harnesses, and control units) of electrically/hydraulically/pneumatically controlled suspension systems (including primary and supplemental suspension and ride control systems).
17. Inspect and repair front (crossmember/subframe) mountings, bushings, brackets, and bolts.

► Rear Suspensions

18. Diagnose rear suspension system noises, handling, ride height and ride quality concerns; determine needed repairs.
19. Inspect and replace rear suspension system coil springs and spring insulators (silencers).
20. Inspect and replace rear suspension system lateral links/arms (track bars), control (trailing) arms, stabilizer bars (sway bars), bushings, and mounts.
21. Inspect and replace rear suspension system leaf spring(s), leaf spring insulators (silencers), shackles, brackets, bushings, center pins/bolts, and mounts.
22. Inspect and replace rear rebound and jounce bumpers.
23. Inspect and replace rear strut cartridge or assembly, and upper mount assembly.
24. Inspect non-independent rear axle assembly for damage and misalignment.
25. Inspect and replace rear ball joints and tie rod/toe link assemblies.
26. Inspect and replace rear knuckle/spindle assembly.
27. Inspect and replace shock absorbers, mounts, and bushings.
28. Diagnose and service rear wheel bearings/hub assemblies.
29. Diagnose, inspect, adjust, repair or replace components (including sensors, switches, actuators, harnesses, and control units) of electrically/hydraulically/pneumatically controlled suspension systems (including primary and supplemental suspension and ride control systems).
30. Inspect and repair rear (crossmember/subframe) mountings, bushings, brackets, and bolts.

C. Wheel Alignment Diagnosis, Adjustment, and Repair (11 questions)

1. Diagnose vehicle wander, drift, pull, hard steering, bump steer (toe curve), memory steer, torque steer, and steering return concerns; determine needed repairs.
2. Measure vehicle ride height; determine needed repairs.
3. Measure front and rear wheel camber; determine needed repairs.
4. Adjust front and/or rear wheel camber on suspension systems with a camber adjustment.
5. Measure caster; determine needed repairs.
6. Adjust caster on suspension systems with a caster adjustment.
7. Measure and adjust front wheel toe.

A4 TASK LIST (CONTINUED)

- Center the steering wheel.
- Measure toe-out-on-turns (turning radius/angle); determine needed repairs.
- Measure SAI/KPI (steering axis inclination/king pin inclination); determine needed repairs.
- Measure included angle; determine needed repairs.
- Measure rear wheel toe; determine needed repairs or adjustments.
- Measure thrust angle; determine needed repairs or adjustments.
- Measure wheelbase setback/offset; determine needed repairs or adjustments.
- Check front and/or rear cradle (crossmember/subframe) alignment; determine needed repairs or adjustments.
- Perform electronic control module calibration/recalibration; perform initialization or relearn procedure as required.
- Diagnose damaged component mounting locations which can cause vibration, steering, and wheel alignment problems in accordance with vehicle manufacturer/industry recommended procedures.

D. Wheel and Tire Diagnosis and Service (5 questions)

- Diagnose tire wear patterns; determine needed repairs.
- Inspect tire condition, size, and application (load and speed ratings).
- Measure and adjust tire air pressure.
- Diagnose wheel/tire vibration, shimmy, and noise concerns; determine needed repairs.
- Rotate tires/wheels and torque fasteners according to manufacturers' recommendations.
- Measure wheel, tire, axle flange, and hub runout (radial and lateral); determine needed repairs.
- Diagnose tire pull (lead) problems; determine corrective actions.
- Dismount and mount tire on wheel.
- Balance wheel and tire assembly.
- Test and diagnose indirect/direct tire pressure monitoring systems (TPMS); determine needed repairs; perform system relearn as required. ■

SAMPLE QUESTIONS

SUSPENSION AND STEERING (TEST A4)

1. While traveling at highway speed, a vibration is felt in the steering wheel and the front end of the vehicle vibrates up and down.
Technician A says that a leaking power steering rack could be the cause.
Technician B says that static out-of-balance of the front tires could be the cause.
Who is right?
- (A) A only
* (B) B only
(C) Both A and B
(D) Neither A nor B
2. A vehicle wanders while being driven on level roads.
Technician A says that too much negative camber could be the cause.
Technician B says that too much positive caster could be the cause.
Who is right?
- (A) A only
(B) B only
(C) Both A and B
* (D) Neither A nor B

	SPECIFICATION	ACTUAL LEFT	ACTUAL RIGHT
CASTER - FRONT	0.00° +/- 0.25°	+0.25°	+0.00°
CAMBER - FRONT	0.50° +/- 0.50°	+0.50°	-0.75°
CAMBER - REAR	0.00° +/- 0.50°	0.00°	0.00°
TOTAL TOE - FRONT	0" +/- 1/32"	-1/8"	+1/16"
TOTAL TOE - REAR	0" +/- 1/32"	0"	0"

3. A vehicle with the alignment readings shown has wear on the inside edge of the right front tire tread and pulls to the left. The cause could be incorrect:
- (A) front caster.
* (B) front camber.
(C) front toe.
(D) rear toe.

A4 SAMPLE QUESTIONS (CONTINUED)

4. A vehicle with rack and pinion steering has a shimmy.
Technician A says that worn rack-to-frame mounting bushings could be the cause.
Technician B says that a binding steering shaft U-joint could be the cause.
Who is right?
- * (A) A only (C) Both A and B
(B) B only (D) Neither A nor B
5. During a wheel alignment, a technician finds the toe-out-on-turns (turning radius) to be incorrect. The cause could be a bent:
- (A) pitman arm.
(B) tie rod.
(C) idler arm.
* (D) steering arm.
6. A vehicle pulls to the right during braking.
Technician A says that a worn strut rod bushing could be the cause.
Technician B says that a bent right wheel could be the cause.
Who is right?
- * (A) A only (C) Both A and B
(B) B only (D) Neither A nor B
7. Which of these should the technician do first when aligning a light truck equipped with a torsion bar front suspension?
- (A) Adjust the thrust angle.
(B) Adjust the caster/camber.
(C) Check/adjust the toe.
* (D) Check/adjust the ride height (curb height).

A4 SAMPLE QUESTIONS (CONTINUED)

8. A pressure test is being performed on a vehicle with power steering. The pressure readings taken when the wheels are at the right and left stops are below specification. The readings are normal when the tester shutoff valve is closed.

Technician A says that these readings could be caused by a failed steering gear.

Technician B says that these readings could be caused by a failed pump.

Who is right?

- * (A) A only
- (B) B only
- (C) Both A and B
- (D) Neither A nor B

9. Ball joint wear is being checked in the suspension shown.

Technician A says that the jack can be placed at X to perform the test.

Technician B says that the jack can be placed at Y to perform the test.

Who is right?

- (A) A only
- * (B) B only
- (C) Both A and B
- (D) Neither A nor B

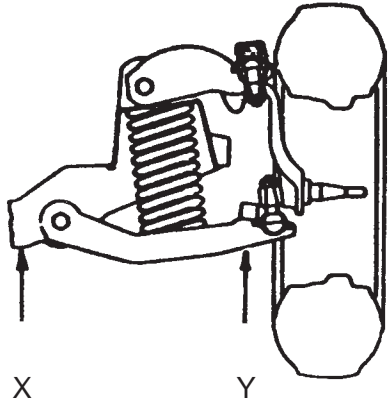

This question contains the word EXCEPT. Read the question carefully before choosing your answer.

10. Any of these could cause tire wear if not within manufacturer's specs EXCEPT:

- * (A) caster.
- (B) wheel balance.
- (C) toe.
- (D) camber.

TEST SPECIFICATIONS AND TASK LIST

BRAKES (TEST A5)

Content Area	Questions in Test	Percentage of Test
A. Hydraulic, Power Assist, and Parking Brake Systems Diagnosis and Repair	19	43%
B. Drum Brake Diagnosis and Repair	5	11%
C. Disc Brake Diagnosis and Repair	11	24%
D. Electronic Brake Control Systems: Antilock Brake System (ABS), Traction Control System (TCS), and Electronic Stability Control System (ESC) Diagnosis and Repair	10	22%
Total	45	100%

A. Hydraulic, Power Assist, and Parking Brake Systems Diagnosis and Repair (19 questions)

► Master Cylinder

1. Diagnose poor stopping, dragging, high or low pedal, and hard or spongy pedal caused by the master cylinder; determine needed repairs.
2. Measure and adjust master cylinder pushrod length.
3. Check master cylinder for failures by depressing brake pedal; determine needed repairs.
4. Diagnose the cause of master cylinder external fluid leakage.
5. Remove and replace master cylinder; bench bleed and install master cylinder; verify master cylinder function.

► Lines and Hoses

6. Diagnose poor stopping, pulling, or dragging caused by problems in the lines and hoses; determine needed repairs.
7. Inspect brake lines and fittings for leaks, dents, kinks, rust, cracks, or wear; inspect for loose fittings and supports; determine needed repairs.
8. Inspect flexible brake hoses for leaks, kinks, cracks, bulging, wear, or corrosion; inspect for loose fittings and supports; determine needed repairs.
9. Replace brake lines, hoses, fittings, and supports; fabricate brake lines using proper material and flaring procedures (double flare and ISO types).
10. Inspect brake lines and hoses for proper routing and support.

A5 TASK LIST (CONTINUED)

► Valves and Switches

11. Diagnose poor stopping, pulling, or dragging caused by problems in the hydraulic system valve(s); determine needed repairs.
12. Inspect, test, and replace metering, proportioning, pressure differential, and combination valves.
13. Inspect, test, replace, and adjust load or height sensing-type proportioning valve(s).
14. Inspect, test, and replace brake system warning lights, indicators, switches, sensors and circuits; test, adjust, and repair or replace brake stop light/brake pedal position switch sensor, lamps, and related circuits.

► Bleeding, Flushing, and Leak Testing

15. Diagnose poor stopping, pulling, dragging, or incorrect pedal travel caused by problems in the brake fluid; determine needed repairs.
16. Bleed and/or flush hydraulic system using manual, pressure, vacuum, or gravity method(s).
17. Pressure test brake hydraulic system.
18. Select, handle, store, and install proper brake fluids (including silicone fluids). Fill master cylinder to proper level.

► Power Assist Units

19. Inspect and test brake pedal linkage for binding, looseness, and adjustment; determine needed repairs.
20. Test pedal free travel with and without engine running to check power booster operation.
21. Check vacuum supply (manifold or auxiliary pump) to vacuum-type power booster.
22. Diagnose vacuum-type power booster unit for vacuum leaks and proper operation; inspect the check valve for proper operation; repair, adjust, or replace parts as necessary.
23. Diagnose hydro-boost system for leaks and proper operation; repair or replace parts as necessary; refill and bleed system following manufacturers' specifications.

► Parking Brake

24. Diagnose parking brake system operation (including electronic parking brakes); inspect cables and parts for wear, rust, and corrosion; clean or replace parts as necessary; lubricate assembly.
25. Adjust parking brake assembly; check operation.
26. Test the parking brake indicator light, switch, and wiring.
27. Retract integral and/or electronic parking brake caliper piston(s) according to manufacturers' specifications.
28. Adjust calipers with integrated parking brakes according to manufacturers' recommendations.

B. Drum Brake Diagnosis and Repair (5 questions)

1. Diagnose poor stopping, pulling, dragging, or incorrect pedal travel caused by drum brake hydraulic problems; determine needed repairs.
2. Diagnose poor stopping, noise, pulling, grabbing, dragging, pedal pulsation, or incorrect pedal travel caused by drum brake mechanical problems; determine needed repairs.

A5 TASK LIST (CONTINUED)

3. Remove, clean, inspect, and measure brake drums; follow manufacturers' recommendations in determining need to machine or replace.
4. Machine drums according to manufacturers' procedures and specifications.
5. Using proper safety procedures, remove, clean, and inspect mechanical brake components, such as: shoes/linings, springs, pins, self-adjusters, levers, clips, brake backing (support) plates, and other related brake hardware; determine needed repairs.
6. Lubricate brake shoe support pads on backing (support) plate, self-adjuster mechanisms, and other brake hardware.
7. Inspect wheel cylinder(s) for leakage, operation, and mounting; remove and replace wheel cylinder(s); bleed system.
8. Following manufacturers' specifications, install brake shoes and related hardware.
9. Preadjust brake shoes and parking brake before installing brake drums or drum/hub assemblies and wheel bearings.
10. Reinstall wheel, torque lug nuts, and make final checks and adjustments.
11. Diagnose wheel bearing noises and vibration problems; determine needed repairs.
12. Remove, clean, inspect, repack wheel bearings, or replace wheel bearings and races; replace seals; replace hub and bearing assemblies; adjust wheel/hub bearings according to manufacturers' specifications.

C. Disc Brake Diagnosis and Repair (11 questions)

1. Diagnose poor stopping, pulling, dragging, or incorrect pedal travel caused by disc brake hydraulic problems; determine needed repairs.
2. Diagnose poor stopping, noise, pulling, grabbing, dragging, pedal pulsation or incorrect pedal travel caused by disc brake mechanical problems; determine needed repairs.
3. Retract brake caliper piston(s) according to manufacturers' recommendations.
4. Remove caliper assembly from mountings; inspect for leaks and damage to caliper housing.
5. Clean and inspect caliper mountings, slides/pins, and threads for wear and damage.
6. Remove, clean, and inspect pads and retaining hardware; determine needed repairs, adjustments, and replacements.
7. Clean caliper assembly; inspect external parts for wear, rust, scoring, and damage; replace any damaged or worn parts; determine the need to repair or replace caliper assembly.
8. Clean, inspect, and measure rotor with a dial indicator and a micrometer; follow manufacturers' recommendations in determining the need to index, machine or replace the rotor.
9. Remove and replace rotor.
10. Machine rotor, using on-car or off-car method, according to manufacturers' procedures and specifications.
11. Install pads, calipers, and related attaching hardware; lubricate components following manufacturers' procedures and specifications; bleed system and inspect for leaks.
12. Reinstall wheel, torque lug nuts, and make final checks and adjustments.
13. Road test vehicle and burnish/break-in pads according to manufacturer's recommendations
14. Diagnose wheel bearing noises and vibration problems; determine needed repairs.

A5 TASK LIST (CONTINUED)

15. Remove, clean, inspect, repack wheel bearings, or replace wheel bearings and races; replace seals; replace hub and bearing assemblies; adjust wheel/hub bearings according to manufacturers' specifications.
16. Distinguish between brake component vibration and tire/wheel vibration; determine needed repairs.

D. Electronic Brake Control Systems: Antilock Brake System (ABS), Traction Control System (TCS), and Electronic Stability Control System (ESC) Diagnosis and Repair (10 questions)

1. Follow manufacturers' service and safety precautions when inspecting, testing, and servicing electronic brake control system hydraulic, electrical, and mechanical components.
2. Diagnose increased stopping distance, wheel lock-up, false activation, pedal feel, pedal travel, pedal pulsation, and noise concerns associated with the electronic brake control system; determine needed repairs.
3. Observe electronic brake control system indicator/light(s) at start-up and during road test; determine if further diagnosis is needed.
4. Diagnose electronic brake control system, electronic control(s), components, and circuits (with or without DTCs) using on-board diagnosis and/or recommended test equipment such as: scan tool, digital multimeter (DMM), digital storage oscilloscope (DSO); determine needed repairs.
5. Bleed and/or flush the electronic brake control hydraulic system following manufacturers' procedures.
6. Remove and install electronic brake control system components following manufacturers' procedures and specifications; perform module set-up/initialization.
7. Test, diagnose and service electronic brake control system sensors (speed, yaw, steering angle, brake pedal position, etc.) and circuits following manufacturers' recommended procedures (includes output signal, resistance, amperage, shorts to voltage/ground, and frequency data.).
8. Diagnose electronic brake control system braking concerns caused by vehicle modifications (wheel/tire size, curb height, final drive ratio, etc.) and other vehicle mechanical and electrical/electronic modifications (communication, security, radio, etc.).
9. Repair wiring harness and connectors following manufacturers' procedures.
10. Diagnose brake problems resulting from failures of interrelated systems (for example: electronic stability control, antilock brake, traction control).
11. Clear diagnostic trouble codes (DTCs) and verify the repair. ■

SAMPLE QUESTIONS BRAKES (TEST A5)

1. Which of these could happen if the measurements in the set-up shown varied from manufacturer's specs?

- (A) Noisy brake operation
- (B) Brake grab or pull
- * (C) Pulsating brake pedal
- (D) Low brake pedal



2. The brake pedal on a vehicle with power-assisted disc/drum brakes moves slowly to the floor during braking. Which of these could be the cause?
- * (A) An internal master cylinder leak
 - (B) A leaking power brake booster diaphragm
 - (C) A leaking brake booster check valve
 - (D) An internal leak in the combination valve
3. On a vehicle with disc/drum brakes, the front brakes grab quickly when light pedal pressure is applied. This could be caused by a failed:
- (A) proportioning valve.
 - (B) pressure differential valve.
 - * (C) metering valve.
 - (D) residual check valve.

A5 SAMPLE QUESTIONS (CONTINUED)

4. On a vehicle with single piston, floating caliper disc brakes, the brake pad against the piston is badly worn. The other brake pad is only slightly worn.
Technician A says that too much rotor runout could be the cause.
Technician B says that a frozen caliper piston could be the cause.
Who is right?
- (A) A only
(B) B only
(C) Both A and B
* (D) Neither A nor B
5. When the brakes are applied, a vibration comes from the front of a vehicle with a disc/drum system. Which of these could be the cause?
- (A) Unequal tire pressure
(B) Binding caliper slides
* (C) Excessive rotor runout
(D) A frozen caliper piston
6. A front disc brake rotor is slightly below minimum thickness specification after machining. The technician should:
- (A) reuse the rotor.
* (B) replace the rotor.
(C) apply a non-directional finish to the rotor.
(D) machine the other front rotor to the same thickness.
7. A hydraulic brake line is leaking. Which of these is the correct repair?
- (A) Cut out the bad section and replace with new steel tubing using compression fittings.
(B) Replace the leaking line with double-flared seamless aluminum tubing.
(C) Cut out the bad section and replace with single-flared steel tubing using flare nuts and unions.
* (D) Replace the leaking line with double-flared steel tubing.

A5 SAMPLE QUESTIONS (CONTINUED)

8. The set-up shown is used to check:

- (A) rotor parallelism.
- (B) wheel bearing adjustment.
- * (C) rotor lateral runout.
- (D) rotor face wear.

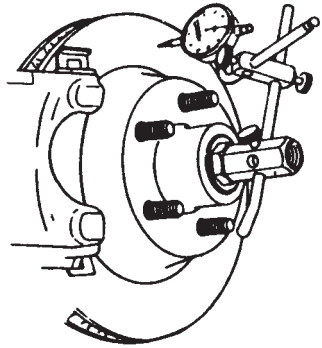

9. The drag on a vehicle's drum brakes increases after each application until they lock up. Bleeding the system restores normal operation for a short time; then drag increases until the brakes lock up again. Which of these could be the cause?

- * (A) A failed master cylinder
- (B) A seized wheel caliper
- (C) Incorrect brake shoe adjustment
- (D) Weak brake shoe return springs

10. With the brakes applied, the pedal moves down slightly when the engine is started on a vehicle with power brakes.

Technician A says that a leaking power brake booster diaphragm could be the cause.

Technician B says that a stuck-closed brake booster vacuum check valve could be the cause.

Who is right?

- (A) A only
- (B) B only
- (C) Both A and B
- * (D) Neither A nor B

TEST SPECIFICATIONS AND TASK LIST

ELECTRICAL/ELECTRONIC SYSTEMS (TEST A6)

Content Area	Questions in Test	Percentage of Test
A. General Electrical/Electronic System Diagnosis	13	26%
B. Battery and Starting System Diagnosis and Repair	9	18%
C. Charging System Diagnosis and Repair	5	10%
D. Lighting Systems Diagnosis and Repair	6	12%
E. Instrument Cluster and Driver Information Systems Diagnosis and Repair	6	12%
F. Body Electrical Systems Diagnosis and Repair	11	22%
Total	50	100%

A. General Electrical/Electronic System Diagnosis (13 questions)

1. Check voltages and voltage drops in electrical/electronic circuits; interpret readings and determine needed repairs.
2. Check current flow in electrical/electronic circuits and components; interpret readings and determine needed repairs.
3. Check continuity and resistances in electrical/electronic circuits and components; interpret readings and determine needed repairs.
4. Check electronic circuit waveforms; interpret readings and determine needed repairs.
5. Use scan-tool data and/or diagnostic trouble codes (DTCs) to diagnose electronic systems; interpret readings and determine necessary action.
6. Find shorts, grounds, opens, and resistance problems in electrical/ electronic circuits; determine needed repairs.
7. Measure and diagnose the cause(s) of abnormal key-off battery drain (parasitic draw); determine needed repairs.
8. Inspect, test, and replace fusible links, circuit breakers, fuses, diodes, and current limiting devices.
9. Read and interpret electrical schematic diagrams and symbols.
10. Research applicable vehicle and service information, such as vehicle service history, service precautions, technical service bulletins, and service campaigns/recalls.
11. Diagnose failures in the data bus communications network; determine needed repairs.
12. Remove and replace control modules; program as needed.

A6 TASK LIST (CONTINUED)

B. Battery and Starting System Diagnosis and Repair (9 questions)

1. Perform battery state-of-charge test; determine needed service.
2. Perform battery tests (load and capacitance); determine needed service.
3. Maintain or restore electronic memory functions.
4. Perform slow/fast battery charge in accordance with manufacturer's recommendations.
5. Inspect, clean, repair and/or replace battery(ies), battery cables, connectors, clamps hold downs, and vent tubes.
6. Jump-start a vehicle using jumper cables, a booster battery or auxiliary power supply.
7. Perform starter current draw test; determine needed repairs.
8. Perform starter circuit voltage drop tests; determine needed repairs.
9. Inspect, test, repair and/or replace starter, relays, solenoids, modules, switches, connectors, and wires of starter circuits.
10. Differentiate between electrical and engine mechanical problems that cause a slow crank, no crank, extended cranking, or a cranking noise condition.

C. Charging System Diagnosis and Repair (5 questions)

1. Diagnose charging system problems that cause a no charge, a low charge, or an overcharge condition; determine needed repairs.
2. Inspect, reinstall and/or replace pulleys, tensioners and drive belts; adjust belts and check alignment.
3. Perform charging system voltage output test; determine needed repairs.
4. Perform charging system current output test; determine needed repairs.
5. Inspect and test generator (alternator) control components including computers/regulators; determine needed repairs.
6. Perform charging circuit voltage drop tests; determine needed repairs.
7. Inspect, test, repair and/or replace connectors and wires of charging system circuits.
8. Remove, inspect, and replace generator (alternator).

D. Lighting Systems Diagnosis and Repair (6 questions)

1. Diagnose the cause of brighter than normal, intermittent, dim, continuous or no operation of exterior lighting; determine needed repairs.
2. Inspect, replace, aim and/or level headlights and auxiliary lights (fog lights/driving lights); inspect and replace headlight and auxiliary bulbs including high-intensity discharge systems (HID).
3. Inspect, test, repair and/or replace switches, relays, bulbs, LEDs, sockets, connectors, wires, and controllers of exterior lighting.
4. Diagnose the cause of turn signal and/or hazard light system malfunctions; determine needed repairs.
5. Inspect, test, repair and/or replace switches, flasher units, bulbs, sockets, connectors, wires, and controllers of turn signal and hazard light circuits.
6. Diagnose the cause of intermittent, dim, continuous or no operation of interior lighting circuits (courtesy, dome, map, vanity, cargo, trunk, and hood); determine needed repairs.
7. Inspect, test, repair and/or replace switches, relays, bulbs, sockets, connectors, wires, and controllers of interior lighting circuits (courtesy, dome, map, vanity, cargo, trunk, and hood).

A6 TASK LIST (CONTINUED)

8. Inspect, test, repair and/or replace trailer wiring harness, relays, connectors, and controllers.

E. Instrument Cluster and Driver Information Systems Diagnosis and Repair (6 questions)

1. Diagnose the cause of intermittent, dim, no lights, continuous operation, or no brightness control of instrument lighting circuits; determine needed repairs.
2. Inspect, test, repair and/or replace switches, relays, bulbs, LEDs, sockets, connectors, wires, and controllers of instrument lighting circuits.
3. Diagnose the cause of high, low, intermittent, or no readings on electronic instrument cluster gauges; determine needed repairs.
4. Diagnose the cause of constant, intermittent, or no operation of warning lights, indicator lights, audible warning devices, and other driver information systems; determine needed repairs.
5. Inspect, test, repair and/or replace bulbs, sockets, connectors, switches, relays, sensors, timers, wires, gauges, sending units, sensors, electronic components, and controllers of electronic instrument clusters and driver information system circuits.

F. Body Electrical Systems Diagnosis and Repair (11 questions)

1. Diagnose operation of comfort and convenience accessories and related circuits (such as: power windows, power seats, pedal height, power locks, truck locks, remote start, moon roof, sun roof, sun shade, remote keyless entry, voice activation, steering wheel controls, back-up camera, park assist, and auto dimming headlamps); determine needed repairs.
2. Inspect, test, repair and/or replace components, connectors and wiring of comfort and convenience accessories.
3. Diagnose operation of heated and cooled accessories and related circuits (such as: heated/cooled seats, heated steering wheel, heated mirror, heated glass, and heated/cooled cup holders); determine needed repairs.
4. Inspect, test, repair and/or replace components, connectors and wiring of heated and cooled accessories.
5. Diagnose operation of security/anti-theft systems and related circuits (such as: theft deterrent, door locks, remote keyless entry, remote start, and starter/fuel disable); determine needed repairs.
6. Inspect, test, repair and/or replace components, connectors and wiring of security/anti-theft systems.
7. Diagnose operation of entertainment and related circuits (such as: radio, DVD, remote CD changer, navigation, amplifiers, speakers, antennas, and voice activated accessories); determine needed repairs.
8. Inspect, test, repair and/or replace components, connectors and wiring of entertainment systems.
9. Diagnose operation of safety systems and related circuits (such as: airbags, seat belt pretensioners, occupancy classification, wipers, washers, speed control/collision avoidance, heads-up display, park assist, and back up camera); determine needed repairs.
10. Inspect, test, repair and/or replace components, connectors and wiring of safety systems. ■

SAMPLE QUESTIONS

ELECTRICAL/ELECTRONIC SYSTEMS (TEST A6)

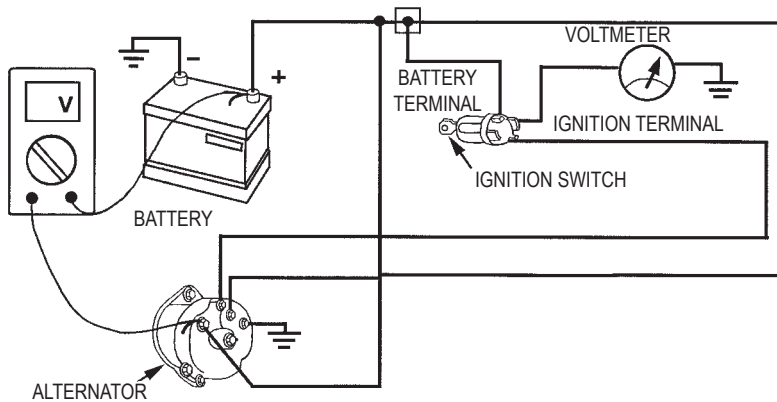

1. In the charging system shown, with the engine running, the digital multimeter (DMM) will display:
 - (A) charging output voltage.
 - (B) regulator operating voltage.
 - * (C) charging circuit voltage drop
 - (D) ignition switch voltage drop.

2. The oil pressure light stays on whenever the engine is running. The oil pressure has been checked and is at specification. Technician A says that a ground in the circuit between the indicator light and the pressure switch could be the cause. Technician B says that an open in the pressure switch could be the cause. Who is right?
 - * (A) A only
 - (B) B only
 - (C) Both A and B
 - (D) Neither A nor B

3. The passenger side power window operates properly when using the passenger side control switch, but the window will operate in the DOWN position only when using the driver's side master control switch. Which of these could be the cause?
 - (A) A pinched wire from the passenger side control switch to the window motor
 - (B) An open wire to the driver's side window motor
 - (C) A grounded power wire to the power window circuit breaker
 - * (D) An open circuit in the driver's side master control switch

A6 SAMPLE QUESTIONS (CONTINUED)

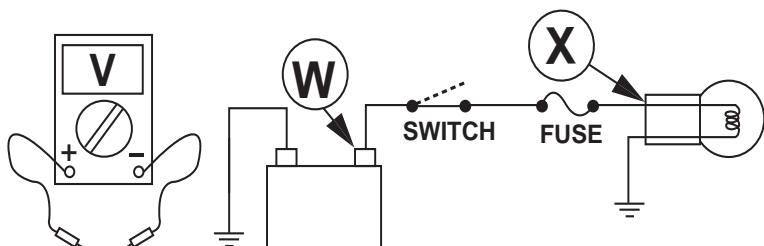

4. The bulb in the circuit shown does not light. To find the actual voltage at the bulb, the technician should touch the positive probe of the voltmeter to:
- (A) point W and the negative probe to ground.
 - (B) ground and the negative probe to point X.
 - * (C) point X and the negative probe to ground.
 - (D) ground and the negative probe to point W.
5. Technician A says that if a fusible link in the alternator charging circuit is replaced with system sized wire, the circuit will be unprotected. Technician B says that if a fusible link in the alternator charging circuit is replaced with system sized wire, the battery will overcharge. Who is right?
- * (A) A only
 - (B) B only
 - (C) Both A and B
 - (D) Neither A nor B
6. A starter solenoid clicks but the starter does not crank the engine. Technician A says that burned solenoid contacts could be the cause. Technician B says that a poor battery cable connection could be the cause. Who is right?
- (A) A only
 - (B) B only
 - * (C) Both A and B
 - (D) Neither A nor B

A6 SAMPLE QUESTIONS (CONTINUED)

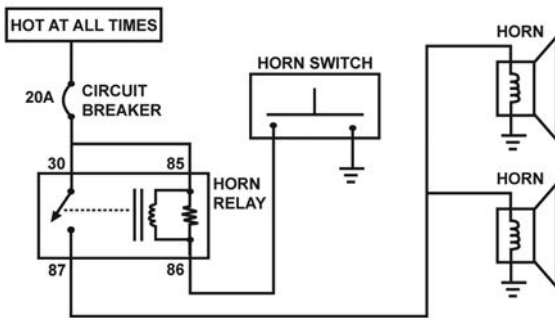

7. The horns in the circuit shown operate only when a jumper wire is connected between terminals 30 and 87 of the horn relay. Technician A says that a failed horn relay could be the cause. Technician B says that a short-to-ground in the circuit between the horn relay and the horn switch could be the cause. Who is right?
- * (A) A only
(B) B only
(C) Both A and B
(D) Neither A nor B

These questions contain the word EXCEPT. Read the questions carefully before choosing your answer.

8. Any of these could cause high starter current draw EXCEPT:
- (A) worn starter bushings.
* (B) a failed starter relay.
(C) grounded field coils.
(D) a seized A/C compressor.
9. The starter will not crank and the solenoid does not click on a vehicle with an automatic transmission. Any of these could be the cause EXCEPT:
- (A) a misadjusted neutral safety switch.
* (B) an open solenoid hold-in winding.
(C) an open circuit between the solenoid and the ignition switch.
(D) an open in the solenoid ground circuit.

TEST SPECIFICATIONS AND TASK LIST

HEATING AND AIR CONDITIONING (TEST A7)

Content Area	Questions in Test	Percentage of Test
A. Heating, Ventilation, A/C (HVAC) and Engine Cooling System Service, Diagnosis, and Repair	21	42%
B. Refrigeration System Component Diagnosis and Repair	10	20%
C. Operating Systems and Related Controls Diagnosis and Repair	19	38%
Total	50	100%

A. Heating, Ventilation, A/C (HVAC) and Engine Cooling System Service, Diagnosis, and Repair (21 questions)

1. Identify system type and conduct performance test on the A/C system; determine needed repairs.
2. Diagnose A/C system problems indicated by system pressures and/or temperature readings; determine needed repairs.
3. Diagnose A/C system problems indicated by sight, sound, smell, and touch procedures; determine needed repairs.
4. Leak test A/C system; determine needed repairs.
5. Identify A/C system refrigerant and existing charge amount; recover refrigerant.
6. Evacuate A/C system.
7. Inspect A/C system components for contamination; determine needed repairs.
8. Charge A/C system with refrigerant.
9. Identify A/C system lubricant type and capacity; replenish lubricant if necessary.
10. Inspect and replace passenger compartment (cabin air, pollen) filter.
11. Disarm and enable the airbag system for vehicle service following manufacturers' recommended procedures.
12. Read diagnostic trouble codes (DTCs) and interpret scan tool data stream.
13. Read and interpret technical literature (service publications, bulletins, recalls, and information including wiring schematics).
14. Use a scan tool, digital multimeter (DMM), or digital storage oscilloscope (DSO) to test HVAC system sensors, actuators, circuits, and control modules; determine needed repairs.
15. Verify proper operation of certified equipment.
16. Recycle or properly dispose of refrigerant.
17. Label and store refrigerant.
18. Test refrigerant cylinders for non-condensable gases; identify refrigerant.

A7 TASK LIST (CONTINUED)

19. Identify the procedures and equipment necessary to service, diagnose, and repair A/C systems in hybrid/electric vehicles.
20. Diagnose the cause of temperature control problems in the heater/ventilation system; determine needed repairs.
21. Diagnose window fogging problems; determine needed repairs.
22. Perform engine cooling system tests (flow, pressure, electrolysis, concentration, and contamination); determine needed repairs.
23. Inspect and replace engine coolant hoses and pipes.
24. Inspect, test, and replace radiator, pressure cap, coolant recovery system, and water pump.
25. Inspect, test, and replace thermostat, thermostat by pass, and housing.
26. Identify, inspect, recover coolant; flush and refill system with proper coolant; bleed system as necessary.
27. Inspect, test, and replace fan (both electrical and mechanical), fan clutch, fan belts, fan shroud, and air dams.
28. Inspect, test, and replace heater coolant control valve (manual, vacuum, and electrical types), and auxiliary coolant pump.
29. Inspect, flush, and replace heater core.

B. Refrigeration System Component Diagnosis and Repair (10 questions)

► Compressor and Clutch

1. Diagnose A/C system problems that cause the protection devices (pressure, thermal, and electronic controls) to interrupt system operation; determine needed repairs.
2. Inspect, test, and replace A/C system pressure, thermal, and electronic protection devices.
3. Inspect, adjust, and replace A/C compressor drive belts, pulleys, and tensioners.
4. Inspect, test, service, and replace A/C compressor clutch components or assembly.
5. Identify required lubricant type; inspect and correct level in A/C compressor.
6. Inspect, test, service or replace A/C compressor, mounting, and fasteners.

► Evaporator, Condenser, and Related Components

7. Inspect, repair, or replace A/C system mufflers, hoses, lines, filters, fittings, and seals.
8. Inspect A/C condenser for proper air flow.
9. Inspect, test, and clean or replace A/C system condenser; check mountings and air seals.
10. Inspect and replace receiver/drier, accumulator/drier, or desiccant.
11. Inspect, test, and replace expansion valve(s).
12. Inspect and replace orifice tube(s).
13. Inspect A/C evaporator for proper air flow.
14. Inspect, test, clean, or replace evaporator(s).
15. Inspect, clean and repair evaporator housing, and water drain.
16. Inspect, test, and replace evaporator pressure/temperature control systems and devices.
17. Identify, inspect, and replace A/C system service valves and valve caps.
18. Inspect and replace A/C system high pressure relief device.

A7 TASK LIST (CONTINUED)

C. Operating Systems and Related Controls Diagnosis and Repair (19 questions)

► Electrical

1. Diagnose the cause of failures in the electrical control system of heating, ventilating, and A/C (HVAC) systems; determine needed repairs.
2. Inspect, test, repair, and replace HVAC heater blower motors, blower motor speed controls, resistors, switches, relays/modules, wiring, and protection devices.
3. Inspect, test, repair, and replace A/C compressor clutch coil, relay/ modules, wiring, sensors, switches, diodes, and protection devices.
4. Inspect, test, repair, and replace A/C-related powertrain control systems and components.
5. Inspect, test, repair, and replace load sensitive A/C compressor cut-off systems.
6. Inspect, test, repair, and replace engine cooling/condenser fan motors, relays/ modules, switches, sensors, wiring, and protection devices.
7. Inspect, test, adjust, repair and replace climate control system electric actuator motors, relays/ modules, switches, sensors, wiring, and protection devices (including dual/multi-zone systems).
8. Inspect, test, service, or replace HVAC panel assemblies.

► Vacuum/Mechanical

9. Diagnose the cause of failures of the heating, ventilating, and A/C (HVAC) vacuum and mechanical control systems; determine needed repairs.
10. Inspect, test, service, or replace HVAC control panel assemblies.
11. Inspect, test, adjust, and replace HVAC control cables and linkages.
12. Inspect, test, and replace HVAC vacuum system actuators (diaphragms/motors), hoses, reservoir, check valve, and restrictors.
13. Inspect, test, adjust, repair, or replace HVAC ducts, doors, and outlets (including dual/multi-zone systems).

► Automatic and Semi-Automatic Heating, Ventilating, and A/C Systems

14. Diagnose temperature control system problems; determine needed repairs (including dual/multi-zone systems).
15. Diagnose blower system problems; determine needed repairs (including dual/multi-zone systems).
16. Diagnose air distribution system problems; determine needed repairs (including dual/multi-zone systems).
17. Diagnose compressor clutch control system; determine needed repairs.
18. Inspect, test, or replace climate and blower control sensors.
19. Inspect, test, and replace door actuator(s).
20. Inspect, test, and replace heater coolant control valve and controls.
21. Inspect, test, and replace electric and vacuum motors, solenoids, and switches.
22. Inspect, test, or replace Automatic Temperature Control (ATC) control panel and/or climate control computer/module; program, code, or initialize as required.
23. Check and adjust calibration of Automatic Temperature Control (ATC) system.
24. Diagnose data communication issues, including diagnostic trouble codes (DTCs) that affect climate control system operation. ■

SAMPLE QUESTIONS

HEATING AND AIR CONDITIONING (TEST A7)

1. Prior to recovery, an unknown refrigerant is identified. The technician should:
 - (A) discharge it into the atmosphere.
 - * (B) recover it and treat it as contaminated.
 - (C) recover it and recycle it as R-12.
 - (D) recover it and recycle it as R-134a.

2. A compressor clutch will not engage. During testing, the technician finds there is 14.2V and a good ground at the clutch coil connector. Which of these could be the cause?
 - (A) A low refrigerant level
 - (B) A seized compressor
 - * (C) An incorrect air gap
 - (D) A bad pressure cycling switch

3. Technician A says that evacuating an A/C system will remove air and moisture from the system. Technician B says that evacuating an A/C system will remove dirt particles from the system. Who is right?
 - * (A) A only
 - (B) B only
 - (C) Both A and B
 - (D) Neither A nor B

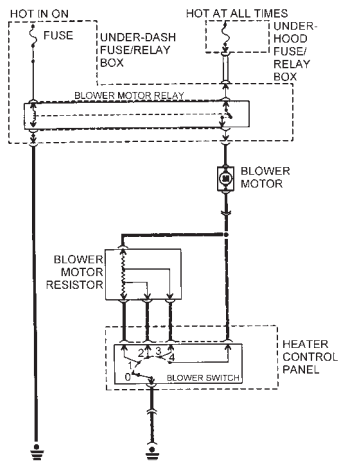

4. The blower motor in the schematic shown works only with the blower switch in the # 4 position. This could be caused by a failed:
 - (A) blower motor.
 - (B) blower motor ground.
 - (C) blower motor relay.
 - * (D) blower motor resistor.

A7 SAMPLE QUESTIONS (CONTINUED)

5. To charge an A/C system while it is running, the refrigerant should be added to:
- (A) the high side only.
 - * (B) the low side only.
 - (C) both the high and the low sides.
 - (D) either the high or the low side.
6. With the A/C system operating at an ambient (outside) temperature of 85° F, the low pressure gauge reads 5 psi and the high pressure gauge reads 105 psi. What do these readings indicate?
- (A) Normal operation
 - * (B) Low refrigerant level
 - (C) A restriction in the high side
 - (D) Broken compressor reed valves
7. The technician measures 14.2 volts at the A/C clutch coil, but the A/C clutch will not engage.
Technician A says that a failed clutch coil could be the cause.
Technician B says that a failed clutch coil ground could be the cause.
Who is right?
- (A) A only
 - (B) B only
 - * (C) Both A and B
 - (D) Neither A nor B

This question contains the word EXCEPT. Read the question carefully before choosing your answer.

8. The high side pressure in an A/C system is above specs. Any of these could be the cause EXCEPT:
- (A) an overcharge of refrigerant.
 - (B) a restricted air flow across the condenser.
 - (C) a plugged expansion valve.
 - * (D) a broken compressor reed valve.

TEST SPECIFICATIONS AND TASK LIST

ENGINE PERFORMANCE (TEST A8)

Content Area	Questions in Test	Percentage of Test
A. General Diagnosis	12	24%
B. Ignition System Diagnosis and Repair	8	16%
C. Fuel, Air Induction and Exhaust Systems Diagnosis and Repair	9	18%
D. Emissions Control Systems Diagnosis and Repair	8	16%
1. Positive Crankcase Ventilation (1)		
2. Exhaust Gas Recirculation (2)		
3. Secondary Air Injection (AIR) and Catalytic Converter (2)		
4. Evaporative Emissions Controls (3)		
E. Computerized Engine Controls Diagnosis and Repair	13	26%
Total	50	100%

A. General Diagnosis (12 questions)

1. Verify driver's complaint, perform visual inspection, and/or road test vehicle; determine needed action.
2. Research applicable vehicle and service information, such as engine management system operation, vehicle service history, service precautions, technical service bulletins, and service campaigns/recalls.
3. Diagnose noises and/or vibration problems related to engine performance; determine needed action.
4. Diagnose the cause of unusual exhaust color, odor, and sound; determine needed action.
5. Perform engine manifold vacuum or pressure tests; determine needed action.
6. Perform cylinder power balance test; determine needed action.
7. Perform cylinder cranking, relative, and running compression tests; interpret test results; determine needed action.
8. Perform cylinder leakage/leak-down test; determine needed action.
9. Diagnose engine mechanical, electrical, electronic, fuel, and ignition problems with an oscilloscope, engine analyzer, and/or scan tool; determine needed action.

A8 TASK LIST (CONTINUED)

10. Prepare and inspect vehicle for HC, CO, NOx, CO₂, and O₂ exhaust gas analysis; perform test and interpret exhaust gas readings.
11. Verify valve adjustment on engines with mechanical or hydraulic lifters.
12. Verify camshaft timing; verify operation of camshaft timing components, including engines equipped with variable valve timing; determine needed action.
13. Diagnose emissions or driveability problems caused by oil related issues, such as incorrect pressure, poor quality, incorrect level, or incorrect type used for the application.
14. Verify engine operating temperature, check coolant level and condition, perform cooling system pressure test; determine needed action.
15. Inspect and test mechanically/hydraulically/electronically operated fans, fan clutch, fan shroud/ducting, and fan control devices; determine needed action.
16. Read and interpret electrical schematic diagrams and symbols.
17. Test and diagnose emissions or driveability problems caused by battery condition, connections, or excessive key-off battery drain; determine needed action.
18. Perform starter current draw test; determine needed action.
19. Perform starter and charging circuit voltage drop tests; determine needed action.
20. Test and diagnose engine performance problems resulting from charging system failures; determine needed action.
21. Inspect, adjust, and replace alternator (generator) drive belts, pulleys, clutches, tensioners and/or fans.
22. Inspect, test, and repair or replace system components, connectors and wires in the starter and charging control circuits.

B. Ignition System Diagnosis and Repair (8 questions)

1. Diagnose ignition system related problems such as no-starting, hard starting, engine misfire, poor driveability, spark knock, power loss, poor mileage, and emissions problems; determine root cause; determine needed action.
2. Interpret ignition system related diagnostic trouble codes (DTCs); determine needed action.
3. Inspect, test, repair, or replace ignition primary circuit wiring and components.
4. Inspect, test, service, repair or replace ignition system secondary circuit wiring and components.
5. Inspect, test, and replace ignition coil(s).
6. Inspect, test, and replace ignition system sensors; adjust as necessary.
7. Inspect, test, and/or replace ignition control module (ICM) and/or powertrain/engine control module (PCM/ECM); reprogram/initialize as needed.

C. Fuel, Air Induction and Exhaust System Diagnosis and Repair (9 questions)

NOTE: Fuel Injection system diagnosis and repair will include vehicles equipped with either multiport or gasoline direct injection (GDI) systems. These systems may be either speed density (based on rpm and MAP) or mass airflow (MAF). When appropriate, the fuel system type will be identified in the ASE test question.

1. Diagnose fuel system related problems, including hot or cold no-starting, hard

A8 TASK LIST (CONTINUED)

- starting, poor driveability, incorrect idle speed, poor idle, flooding, hesitation, surging, engine misfire, power loss, stalling, poor mileage, and emissions problems; determine root cause; determine needed action.
2. Interpret fuel or induction system related diagnostic trouble codes (DTCs); analyze fuel trim and other scan tool data; determine needed action.
 3. Inspect fuel tank, filler neck, and gas cap; inspect and replace fuel lines, fittings, and hoses; determine needed action.
 4. Inspect, test, and replace fuel pump(s) and/or fuel pump assembly; inspect, service, and replace fuel filters.
 5. Inspect and test fuel pump control circuits and components; determine needed action.
 6. Inspect, test, and repair or replace fuel pressure regulation system and components of fuel injection systems; check fuel for contaminants and quality; perform fuel pressure/volume test.
 7. Inspect, test, service and/or replace throttle assembly; make related adjustments and/or perform initialization or relearn procedure as required.
 8. Inspect, test, clean, and replace fuel injectors and fuel rails.
 9. Inspect, service, and repair or replace air filtration system components.
 10. Inspect throttle assembly, air induction system, intake manifold and gaskets for air/vacuum leaks, restrictions and/or unmetered air.
 11. Remove, clean, inspect, test, and repair or replace fuel system vacuum and electrical components and connections.
 12. Inspect, service, and replace exhaust manifold, exhaust pipes, oxygen sensors, air/fuel ratio sensors, mufflers, catalytic converters, resonators, tailpipes, and heat shields.
 13. Test for exhaust system restriction or leaks; determine needed action.
 14. Inspect, test, clean and repair or replace turbocharger or supercharger and system components.

D. Emissions Control Systems Diagnosis and Repair (8 questions)

1. Positive Crankcase Ventilation (1 question)

1. Test and diagnose emissions or driveability problems caused by positive crankcase ventilation (PCV) system.
2. Inspect, service, and replace positive crankcase ventilation (PCV) filter/breather cap, valve, oil separator tubes, orifice/metering device, and hoses.

2. Exhaust Gas Recirculation (2 questions)

1. Test and diagnose driveability problems caused by the exhaust gas recirculation (EGR) system.
2. Interpret exhaust gas recirculation (EGR) related scan tool data and diagnostic trouble codes (DTCs); determine needed action.
3. Inspect, test, service, and replace components of the EGR system, including EGR valve, tubing, passages, vacuum/pressure controls, filters, hoses, electrical/electronic sensors, controls, solenoids and wiring of exhaust gas recirculation (EGR) systems.

3. Secondary Air Injection (AIR) and Catalytic Converter (2 questions)

1. Test and diagnose emissions or driveability problems caused by the secondary air injection or catalytic converter systems.
2. Interpret secondary air injection system related scan tool data and diagnostic trouble

A8 TASK LIST (CONTINUED)

codes (DTCs); determine needed action.

3. Inspect, test, service, and replace mechanical components and electrical/electronic components and circuits of secondary air injection systems.
4. Inspect catalytic converter. Interpret catalytic converter related diagnostic trouble codes (DTCs); analyze related scan tool data to determine root cause of DTCs; determine needed action.

4. Evaporative Emissions Controls (3 questions)

1. Test and diagnose emissions or driveability problems caused by the evaporative emissions control system.
2. Interpret evaporative emissions-related scan tool data and diagnostic trouble codes (DTCs); determine needed action.
3. Inspect, test, and replace canister, lines/hoses, filters, mechanical and electrical components of the evaporative emissions control system.

E. Computerized Engine Controls Diagnosis and Repair (13 questions)

1. Retrieve and record diagnostic trouble codes (DTCs), OBD II monitor status and freeze frame data.
2. Diagnose the causes of emissions or driveability problems with stored or active diagnostic trouble codes (DTCs).
3. Diagnose the causes of emissions or driveability problems without diagnostic trouble codes (DTCs).
4. Use a scan tool, digital multimeter (DMM), or digital storage oscilloscope (DSO) to inspect or test computerized engine control system sensors, actuators, circuits, and powertrain/engine control module (PCM/ECM); determine needed action.
5. Measure and interpret voltage, voltage drop, amperage, and resistance using digital multimeter (DMM) readings.
6. Test, remove, inspect, clean, service, and repair or replace power and ground distribution circuits and connections.
7. Inspect, test, and/or replace the powertrain/engine control module (PCM/ECM); reprogram/initialize as needed.
8. Diagnose driveability and emissions problems resulting from failures of interrelated systems (for example: cruise control, security alarms/theft deterrent, torque controls, traction controls, torque management, A/C, non-OEM installed accessories).
9. Clear diagnostic trouble codes (DTCs), run all OBD II monitors, and verify the repair. ■

SAMPLE QUESTIONS

ENGINE PERFORMANCE (TEST A8)

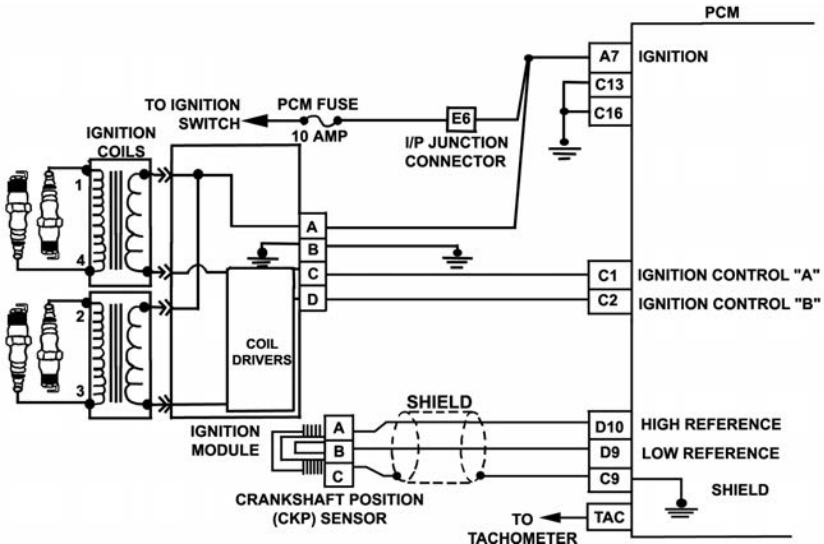

- An engine equipped with the ignition system shown misfires on cylinders #1 and #4. Technician A says that a failed ignition coil could be the cause. Technician B says that a weak rpm signal to the PCM could be the cause. Who is right?

* (A) A only (C) Both A and B
(B) B only (D) Neither A nor B
- While the engine is running, a technician pulls the PCV valve out of the valve cover and plugs the valve opening. There are no changes in engine operation. Technician A says that the PCV valve could be stuck in the open position. Technician B says that the hose between the intake manifold and the PCV valve could be plugged. Who is right?

(A) A only (C) Both A and B
* (B) B only (D) Neither A nor B

A8 SAMPLE QUESTIONS (CONTINUED)

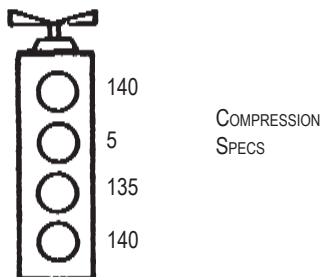

3. After the compression readings shown in the illustration were taken, a wet compression test was made. The second set of readings was almost the same as the first. Technician A says that a burned valve could cause these readings. Technician B says that a broken piston ring could cause these readings. Who is right?
- * (A) A only
(B) B only
- (C) Both A and B
(D) Neither A nor B
4. Blue smoke comes from the exhaust pipe of a vehicle. Technician A says that blocked cylinder head oil return passages could be the cause. Technician B says that a stuck-open engine thermostat could be the cause. Who is right?
- * (A) A only
(B) B only
- (C) Both A and B
(D) Neither A nor B
5. A vehicle is being diagnosed for poor fuel economy. Engine tests show a rich exhaust gas mixture. Technician A says that a failed oxygen (O_2) sensor could be the cause. Technician B says that a failed engine coolant temperature sensor could be the cause. Who is right?
- (A) A only
(B) B only
- * (C) Both A and B
(D) Neither A nor B

A8 SAMPLE QUESTIONS (CONTINUED)

6. A vacuum gauge is connected to the intake manifold of an engine. With the engine running at 2,000 rpm, the pointer on the gauge fluctuates rapidly between 10 and 22 in.Hg. The cause could be:
- (A) a leaking intake manifold gasket.
 - (B) worn piston rings.
 - (C) worn valve guides.
 - * (D) a broken valve spring.
7. The technician finds no spark and no injector pulses on a vehicle that will not start. The cause could be a failed:
- (A) mass airflow sensor (MAF).
 - * (B) crankshaft position (CKP) sensor.
 - (C) throttle position sensor (TPS).
 - (D) fuel pump (FP) module.
8. An engine with a return-type electronic fuel injection (EFI) system has high fuel pressure at idle. Which of these could be the cause?
- * (A) Low manifold vacuum
 - (B) A leaking fuel pump check valve
 - (C) A plugged fuel injector
 - (D) High manifold vacuum
9. Which of these could cause a catalytic converter to overheat?
- (A) A broken air pump drive belt
 - (B) A plugged canister purge vacuum hose
 - (C) A stuck-closed EGR valve
 - * (D) A disconnected spark plug wire

This question contains the word EXCEPT. Read the question carefully before choosing your answer.

10. Engine detonation (knock) could be caused by any of these EXCEPT:
- (A) a lean air fuel mixture.
 - * (B) retarded ignition timing.
 - (C) excess carbon in the combustion chambers.
 - (D) a stuck-closed exhaust gas recirculation (EGR) valve.

TEST SPECIFICATIONS AND TASK LIST

LIGHT VEHICLE DIESEL ENGINES (TEST A9)

Content Area	Questions in Test	Percentage of Test
A. General Diagnosis	9	18%
B. Cylinder Head and Valve Train Diagnosis and Repair	5	10%
C. Engine Block Diagnosis and Repair	5	10%
D. Lubrication and Cooling Systems Diagnosis and Repair	6	12%
E. Air Induction and Exhaust Systems Diagnosis and Repair	12	24%
F. Fuel System Diagnosis and Repair	13	26%
Total	50	100%

A. General Diagnosis (9 questions)

1. Verify the complaint, and road/dyno test vehicle; review driver/customer concerns/expectations and vehicle service history (if available); determine further diagnosis.
2. Record vehicle identification number (VIN). Identify engine model, calibration and serial numbers to research applicable vehicle and service information, service precautions, and technical service bulletins; determine needed actions.
3. Perform scan tool check and visual inspection for physical damage and missing, modified, or tampered components; determine needed actions.
4. Check and record electronic diagnostic codes, freeze frame and/or operational data; monitor scan tool data; determine further diagnosis.
5. Clear diagnostic trouble codes (DTCs) and verify the repair.
6. Inspect engine assembly and compartment for fuel, oil, coolant, exhaust, or other leaks; determine needed repairs.
7. Inspect engine compartment wiring harness, connectors, seals, and locks; check for proper routing and condition; determine needed repairs.
8. Listen for and isolate engine noises; determine needed repairs.
9. Isolate and diagnose engine related vibration problems; determine needed actions.
10. Check engine exhaust for abnormal odor and/or smoke color and volume; determine further diagnosis.
11. Check fuel for contamination, quantity, quality, and consumption; determine needed actions.
12. Perform crankcase pressure test; determine further diagnosis.
13. Diagnose surging, rough operation, misfiring, low power, slow deceleration, slow acceleration, and shutdown problems; determine needed actions.
14. Check cooling system for freeze point, level, contamination, condition, temperature, pressure, circulation, and fan operation; determine needed repairs.

A9 TASK LIST (CONTINUED)

15. Check lubrication system for contamination, oil level, temperature, pressure, filtration, and oil consumption; take oil sample and obtain oil analysis if needed; determine needed repairs.
16. Diagnose no-cranking, cranks but fails to start, hard starting, and starts but does not continue to run problems; determine needed actions.
17. Diagnose engine problems caused by battery condition, connections, or excessive key-off battery drain; determine needed repairs.
18. Diagnose engine problems resulting from an electrical undercharge, overcharge, or a no-charge condition; determine needed action.

B. Cylinder Head and Valve Train Diagnosis and Repair (5 questions)

1. Remove, inspect, disassemble, and clean cylinder head assembly(s).
2. Inspect threaded holes, studs, and bolts for serviceability; service/replace as needed.
3. Measure cylinder head thickness, and check mating surfaces for flatness, corrosion, warpage and surface finish; inspect for cracks/damage; check condition of passages; inspect core and gallery plugs; determine serviceability and needed repairs.
4. Inspect valves, guides, seats, springs, retainers, rotators, locks and seals; determine serviceability and needed repairs.
5. Inspect and/or replace injector sleeves, glow plug sleeves, and seals; pressure test to verify repair (if applicable); measure injector tip, nozzle, or prechamber protrusion where specified by manufacturer.
6. Inspect, and/or replace valve bridges (crossheads) and guides; adjust bridges (crossheads) if applicable.
7. Reassemble, check, and determine required cylinder head gasket thickness; install cylinder head assembly and gasket as specified by the manufacturer.
8. Inspect pushrods, rocker arms, rocker arm shafts, electronic components, wiring harness, seals; repair/replace as needed.
9. Inspect, install, and adjust cam followers, lash adjusters and retainers; adjust valve clearance if applicable.
10. Inspect, measure, and replace/reinstall overhead camshaft and bearings; measure and adjust endplay.
11. Inspect and time drive gear train components (includes gear, chain, and belt systems).

C. Engine Block Diagnosis and Repair (5 questions)

1. Remove, inspect, service, and install pans, covers, ventilation systems, gaskets, seals, and wear rings.
2. Disassemble, clean and inspect engine block for cracks; check mating surfaces and related components for damage or warpage and surface finish; check deck height; check condition of passages, core, and gallery plugs; inspect threaded holes, studs, dowel pins and bolts for serviceability; service/replace as needed.
3. Inspect and measure cylinder walls for wear and damage; determine needed service.
4. Inspect in-block camshaft bearings for wear and damage; replace as needed.
5. Inspect, measure, and replace/reinstall in-block camshaft; measure and correct end play; inspect, replace/reinstall, and adjust cam followers (if applicable).
6. Clean and inspect crankshaft and journals for surface finish, cracks, and damage; check condition of oil passages; check passage plugs; measure journal diameters; check mounting surfaces; determine needed service.
7. Determine the proper select-fit components such as pistons, connecting rod and main bearings.

A9 TASK LIST (CONTINUED)

8. Inspect and replace main bearings; check cap fit and bearing clearances; check and correct crankshaft end play.
9. Inspect, replace, verify, and adjust the drive gear train components (includes gear, chain, and belt systems).
10. Inspect, measure, or replace pistons, pins, and retainers.
11. Measure piston-to-cylinder wall clearance.
12. Identify piston, connecting rod bearing, and main bearing wear patterns that indicate connecting rod and crankshaft alignment or bearing bore problems; check bearing bore and bushing condition; determine needed repairs.
13. Check ring-to-groove fit and end gaps; install rings on pistons; assemble pistons and connecting rods and install in block; check piston height/protrusion; check liner height/protrusion (if applicable); replace rod bearings and check clearances; check condition, position, and clearance of piston cooling jets (nozzles).
14. Inspect crankshaft vibration damper; determine needed repairs.
15. Inspect flywheel/flexplate and/or dual-mass flywheel (including ring gear) and mounting surfaces for cracks, wear, and runout; determine needed repairs.

D. Lubrication and Cooling Systems Diagnosis and Repair (6 questions)

1. Verify base engine oil pressure and check operation of pressure sensor/switch and pressure gauge; verify engine oil temperature and check operation of temperature sensor.
2. Inspect, measure, repair/replace oil pump, housing, drives, pipes, and screens; check drive gear clearance.
3. Inspect, repair/replace oil pressure regulator assembly including: housing, bore, spring, regulator valve(s), oil filter by-pass valve(s), and anti-drain back valve.
4. Inspect, clean, test, and reinstall/replace oil cooler, by-pass valve, lines, and hoses.
5. Inspect turbocharger lubrication and cooling systems; repair/replace as needed.
6. Change engine oil and filters using proper type, viscosity, and rating per manufacturer specifications.
7. Inspect and reinstall/replace pulleys, tensioners, and drive belts; adjust drive belts and check alignment.
8. Verify coolant temperature; check operation of temperature and level sensors, switches, and temperature gauge.
9. Inspect and replace thermostat(s), by-pass(es), housing(s), and seal(s).
10. Flush and refill cooling system; following manufacturer's specification, add proper coolant type; bleed air from system.
11. Inspect and replace water pump(s), housing(s), hoses, and idler pulley(s) or drive gear.
12. Inspect radiator(s), pressure cap(s), and tank(s); pressure test cooling system and radiator cap(s); determine needed repairs.
13. Inspect and repair/replace cooling fan, fan hub, fan clutch, controls, and shroud(s).

E. Air Induction and Exhaust Systems Diagnosis and Repair (12 questions)

1. Inspect and service/replace air induction piping, air cleaner, and element; determine needed actions.
2. Perform intake manifold pressure tests; inspect, test, clean, and/or replace charge air cooler and piping system; determine needed actions.

A9 TASK LIST (CONTINUED)

3. Inspect test, and replace turbocharger(s) (including variable ratio/geometry VGT), pneumatic, hydraulic, vacuum, and electronic controls and actuators; inspect, test, and replace wastegate and wastegate controls.
4. Inspect, test, and replace intake manifold(s), variable intake manifold(s), gaskets, actuators, temperature and pressure sensors, and connections.
5. Perform exhaust back pressure and temperature tests; determine needed actions.
6. Inspect and repair/replace exhaust manifold(s), gaskets, piping, mufflers, and mounting hardware.
7. Inspect, test, and repair/replace preheater/inlet air heater and/or glow plug system and controls.
8. Inspect, test, and replace exhaust aftertreatment system components and controls, including diesel oxidation catalyst (DOC), selective catalyst reduction (SCR), diesel exhaust fluid (DEF), diesel particulate filter (DPF); check regeneration system operation.
9. Inspect, test, service, and replace EGR system components including EGR valve(s), EGR cooler by-pass valve(s), EGR cooler(s), piping, electronic sensors, actuators, controls, and wiring.
10. Inspect, test, and replace airflow control (throttle) valve(s) and controls.
11. Inspect, test, and replace crankcase ventilation system components, including sensors, filters, valves, and piping.

F. Fuel System Diagnosis and Repair (13 questions)

1. Inspect, clean, test, and repair/replace fuel system tanks, vents, caps, mounts, valves, single/dual supply and return lines, and fittings.
2. Inspect, clean, test, and repair/replace fuel transfer and/or supply pump, sensors, strainers, fuel/water separators/indicators, filters, heaters, coolers, ECM cooling plates (if applicable), and mounting hardware.
3. Check fuel system for air; determine needed repairs; prime and bleed fuel system; check and repair/replace primer pump.
4. Inspect, test, and repair/replace low fuel pressure regulator supply and return systems, including low pressure switches.
5. Inspect and reinstall/replace high-pressure injection lines, fittings, transfer tubes, seals, and mounting hardware.
6. Inspect, adjust, and repair/replace electronic throttle and PTO control devices, circuits, and sensors.
7. Perform on-engine inspections, tests, and replace high pressure common rail fuel system components and electronic controls.
8. Perform on-engine inspections and tests; replace hydraulic electronic unit injector(s) (HEUI) components and electronic controls.
9. Perform on-engine inspections and tests; replace pump-line-nozzle fuel system (PLN-E) components and electronic controls.
10. Perform on-engine inspections and tests; replace electronic unit injector(s) (EUI) components and electronic controls.
11. Inspect and replace electrical connector terminals, pins, harnesses, seals, and locks.
12. Connect diagnostic scan tool to vehicle/engine; access, verify and update software calibration settings, injector calibration codes; perform control module re-learn procedures as needed.

-
13. Use a diagnostic scan tool to inspect and test electronic engine control system, sensors, actuators, electronic control modules, and circuits; determine further diagnosis.
 14. Measure and interpret voltage, voltage drop, amperage, and resistance readings using a digital multimeter (DMM) or appropriate test equipment.
 15. Diagnose engine problems resulting from failures of interrelated systems (for example: cruise control, security alarms/theft deterrent, transmission controls, exhaust aftertreatment systems, electronic stability control, or non-OEM installed accessories). ■

SAMPLE QUESTIONS

LIGHT VEHICLE DIESEL ENGINES (TEST A9)

1. An electronic diesel engine has an active diagnostic trouble code for "Cylinder #3 Misfire." This could be caused by:
* (A) low compression in the #3 cylinder.
(B) an open #3 cylinder glow plug.
(C) a shorted #3 cylinder glow plug.
(D) an incorrect fuel cetane rating.

2. A vehicle has low power under load. Which of these could be the cause?
* (A) A leaking charge air cooler
(B) A leak in the turbocharger inlet piping
(C) Using an off road grade of fuel
(D) An open in the mass airflow sensor circuit

3. A vehicle equipped with a HEUI fuel system is hard to start at engine temperatures lower than 35° F (1.7° C).
Technician A says that worn injectors could be the cause.
Technician B says that an open glow plug could be the cause.
Who is right?
* (A) A only
(B) B only
(C) Both A and B
(D) Neither A nor B

4. Technician A says that the vanes in a variable geometry turbo (VGT) system are closed at wide open throttle (WOT).
Technician B says that sticking vanes in a variable geometry turbo (VGT) system can be determined by observing the MAF sensor voltage readings on a scan tool.
Who is right?
(A) A only
(B) B only
(C) Both A and B
* (D) Neither A nor B

A9 SAMPLE QUESTIONS (CONTINUED)

5. An electronic fuel injector on a diesel engine with a high-pressure common rail injection system is being replaced. The information at point Y in the illustration show indicates the injector:

- (A) bar code.
- (B) maximum pressure rating.
- (C) opening pressure.
- * (D) calibration coding.

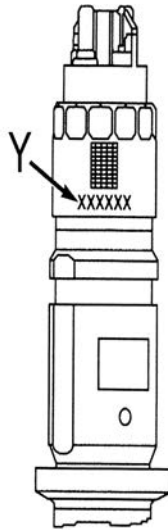

This question contains the word EXCEPT. Read the question carefully before choosing your answer.

6. The owner of a diesel vehicle complains of a serious vibration at idle. Any of these could be the cause EXCEPT:
- (A) a broken motor mount.
 - (B) misfiring cylinders.
 - (C) an incorrect idle speed.
 - * (D) a stuck-closed EGR valve.

TEST SPECIFICATIONS AND TASK LIST

AUTOMOBILE SERVICE CONSULTANT (TEST C1)

Content Area	Questions in Test	Percentage of Test
A. Communications	23	46%
B. Product Knowledge	18	36%
C. Shop Operations	9	18%
Total	50	100%

A. Communications (23 questions)

► Customer Relations

1. Demonstrate professional telephone skills.
2. Obtain, confirm, and document pertinent vehicle/customer contact information.
3. Communicate with customer and document customer concern/request.
4. Demonstrate professional greeting skills/acknowledgement.
5. Discuss alternative transportation options.
6. Promote procedures, benefits, and capabilities of service facility.
7. Review vehicle service history.
8. Identify and communicate recommended service and maintenance needs.
9. Establish vehicle status/completion expectations.
10. Confirm the accuracy of the repair order and obtain repair/service authorization.
11. Identify customer type (first time, warranty, repeat repair, fleet, etc.) and source of payment as necessary.
12. Present professional image.
13. Perform customer follow-up.
14. Explain and confirm invoice accuracy, understanding of work performed or declined charges, and warranties.
15. Handle customer complaints.

► Sales Skills

16. Provide and explain estimates.
17. Identify and prioritize vehicle needs and/or service recommendations.
18. Address original concerns with customer.
19. Communicate the value of related and additional services.
20. Communicate product/service features and benefits.
21. Overcome objections/finalize sale.

C1 TASK LIST (CONTINUED)

B. Product Knowledge (18 questions)

- ▶ **Engine Systems (Includes Computer Controls, Mechanical, Cooling, Fuel, Ignition, Exhaust, Emissions Control, and Starting/Charging)**
 1. Identify major components and location.
 2. Identify the basic function of major components.
 3. Identify related items
- ▶ **Drive Train Systems (Includes Computer Controls, Manual Transmission/Transaxles, Automatic Transmission/Transaxles, and Drive Train Components)**
 4. Identify major components and location.
 5. Identify component function.
 6. Identify related items.
- ▶ **Chassis Systems (Includes Computer Controls, Frames, Brakes, ABS, Traction Control, Suspension, Steering, Wheels, Tires, and TPMS)**
 7. Identify major components and location.
 8. Identify component function.
 9. Identify related items.
- ▶ **Body Systems (Includes Computer Controls, Body Components, Glass, Heating and Air Conditioning, Electrical, Restraint, and Accessories)**
 10. Identify major components and location.
 11. Identify component function.
 12. Identify related items.
- ▶ **Services/Maintenance Intervals**
 13. Understand the elements of a maintenance procedure.
 14. Identify and communicate related maintenance and reset and follow up procedures.
 15. Locate and interpret maintenance schedule information.
- ▶ **Warranty, Service Contracts, Service Bulletins, and Campaigns/Recalls**
 16. Demonstrate knowledge of warranty policies, procedures, and parameters.
 17. Locate and use reference information for warranties, service contracts, service bulletins, and campaigns/recalls.
 18. Demonstrate general knowledge of service contracts, technical service bulletins, campaigns and recalls.
 19. Determine the application of warranty, service contracts, and campaigns/recalls.
- ▶ **Vehicle Identification**
 20. Locate and utilize vehicle ID number (VIN).
 21. Locate production date.
 22. Locate and utilize component identification data.
 23. Identify body styles.

C. Shop Operations (9 questions)

1. Manage work flow.
2. Demonstrate knowledge of sublet procedures.
3. Maintain customer appointment log.

C1 TASK LIST (CONTINUED)

4. Address repeat repairs/comebacks.
5. Manage after hours vehicles.

► Internal Relations

6. Effectively communicate customer service concern/request.
7. Understand the technician's diagnosis and service recommendations.
8. Verify availability of parts.
9. Establish completion expectations.
10. Monitor repair/service progress.
11. Document information about recommended services performed or declined.
12. Communicate with shop personnel about shop production/efficiency and repair/service quality.
13. Maintain open lines of communication within the organization. ■

SAMPLE QUESTIONS

AUTOMOBILE SERVICE CONSULTANT (TEST C1)

1. A customer requests that the timing be adjusted on their vehicle. The service consultant should:
 - (A) explain that ignition timing may not be adjustable.
 - * (B) ask the customer about their vehicle symptoms.
 - (C) quote a price for the request.
 - (D) suggest new spark plugs with the service.

2. A customer comes in for a 30,000 mile service. While completing the service, the technician notes that the vehicle will soon need the front brake pads replaced. Which of these is the best way to address this need with the customer?
 - (A) Note the technician's comments on the customer's repair order.
 - (B) Input the technician's comments in the dealership's database for review at the next service
 - * (C) Call the customer and offer to complete the repair explaining why it is needed.
 - (D) Address the need when the customer arrives to pick up their vehicle.

3. Which of these functions is performed by the engine timing belt?
 - (A) It connects the pistons to the crankshaft.
 - (B) It can be used to adjust spark timing.
 - * (C) It drives the camshaft.
 - (D) It controls engine RPM.

4. A vehicle's ABS light remains on while driving.
Service Consultant A says that while the light is on, the ABS system will still function.
Service Consultant B says that while the light is on, the mechanical brake system will still function.
Who is right?
 - (A) A only
 - * (B) B only
 - (C) Both A and B
 - (D) Neither A nor B

C1 SAMPLE QUESTIONS (CONTINUED)

5. Service Consultant A says that maintenance schedules are most likely found in the extended warranty contract. Service Consultant B says that maintenance schedules are based on time and mileage. Who is right?
- (A) A only
 - * (B) B only
 - (C) Both A and B
 - (D) Neither A nor B

This question contains the word EXCEPT. Read the question carefully before choosing your answer.

6. Any of these are maintenance items EXCEPT a:
- (A) transmission flush.
 - (B) 60 K service.
 - * (C) water pump leak.
 - (D) tire rotation.
7. When discussing recommended repairs with the customer, the service consultant should always:
- * (A) help prioritize all recommendations.
 - (B) ask how long they intend to keep the vehicle.
 - (C) start at the front of the car and work back.
 - (D) start with maintenance items.
8. Service consultants can judge shop capacity and work flow by:
- * (A) using a service scheduling tool and tracking sold labor hours.
 - (B) reviewing part arrival times.
 - (C) communicating with customers and getting more time to complete repairs.
 - (D) reducing larger jobs in the shop.

TEST SPECIFICATIONS AND TASK LIST

COMPRESSED NATURAL GAS VEHICLE (TEST F1)

Content Area	Questions in Test	Percentage of Test
A. Vehicle Inspection for Condition, Suitability, and Compliance	5	9%
B. Equipment Suitability Installation and Inspection	8	15%
C. Leak Testing and Repairs	6	11%
D. Emissions, Performance Verification, and Adjustments	11	20%
E. System Diagnosis, Maintenance, and Repair	16	29%
F. General Cylinder Safety and Maintenance	9	16%
Total	55	100%

Note: All CNG vehicle conversion, testing, service, and repair should be performed using vehicle and component manufacturer's guidelines and current NFPA 52 and/or local safety standards.

A. Vehicle Inspection for Condition, Suitability and Compliance (5 questions)

1. Inspect vehicle for fitness (weight, mileage, applicable emissions standards, and safety standards).
2. Analyze engine performance; determine needed repairs.
3. Verify size, weight and capacity of compressed natural gas cylinder(s).
4. Inspect for proper location and mounting of compressed natural gas cylinders and fuel system components.
5. Inspect for location, condition and compliance of venting system(s).

B. Equipment Installation and Inspection (8 questions)

1. Visually inspect fuel storage cylinders and system components prior to installation.
2. Install fuel storage system; secure with recommended brackets, isolators, reinforcements, and fasteners; inspect fuel storage system.
3. Install/inspect regulator assembly(ies) and coolant lines as required.
4. Install/inspect underhood fuel delivery system components.
5. Install and connect/inspect system wiring.
6. Install/inspect electrical and electronic components.
7. Install/inspect instrument panel components.

F1 TASK LIST (CONTINUED)

8. Install / inspect fuel lines, clamps, filters, and fittings.
9. Install / inspect valves, pressure relief devices, venting systems, lines and fittings; secure with recommended fasteners.
10. Install / inspect fuel fill receptacle(s) and check valve(s).
11. Install / inspect required labels.
12. Complete system documentation as required.

C. Leak Testing and Repairs (6 questions)

1. Check for low and high-pressure natural gas leaks; repair as needed.
2. Pressurize cylinders with natural gas.
3. Check for coolant leaks; repair as needed.
4. Check venting system integrity as required.

D. Emissions, Performance Verification and Adjustments (11 questions)

1. Check base ignition timing; adjust where applicable.
2. Check regulator(s) pressure(s); adjust where applicable.
3. Check mixture settings; adjust where applicable.
4. Verify Power Train Control Module(s) (PCM) Calibration.
5. Check operation of electronic components.
6. Check operation of fuel gauge; make repairs as required.
7. Perform emission tests; make repairs and document where applicable.
8. Road test vehicle for acceptable driveability; check starting/restarting abilities.
9. Check manual and automatic fuel changeover operation (bi-fuel vehicles).
10. Check fuel system for abnormal noises.
11. Verify gaseous fuel management operation.

E. System Diagnosis Maintenance and Repair (16 questions)

Note: The following tasks apply to both bi-fuel and dedicated CNG vehicles.

1. Interpret and verify operational complaint; determine needed repair.
2. Visually inspect gaseous fuel system components; determine needed repairs.
3. Retrieve and interpret Diagnostic Trouble Codes (DTC) through the use of recommended PC based software, DMM, and/or scan tool.
4. Diagnose driveability and emissions problems related to the ignition system; determine needed repairs.
5. Diagnose driveability and emissions problems related to fuel and air induction systems, and exhaust systems; determine needed repairs.
6. Diagnose driveability and emissions problems related to electronic engine controls; determine needed repairs.
7. Check vacuum/electrical/electronic component operation; repair or replace as needed.
8. Check gaseous fuel delivery system pressures, component operation; repair or replace as needed.
9. Remove and/or replace fuel lines, manual and electrical valves, fittings, and pressure relief devices.
10. De-fuel CNG system.
11. Check for signs of fuel contamination; inspect, replace and/or service fuel system filters as required.

F1 TASK LIST (CONTINUED)

F. General Cylinder Safety and Maintenance (9 questions)

1. Visually inspect fuel storage cylinder(s), shields and mounting.
2. Remove and replace cylinders; de-fuel according to recommended procedures; replace shields, brackets, and hardware as required.
3. Handle and store cylinders in accordance with recommended procedures.
4. Interpret cylinder label information; determine necessary action.
5. Inspect pressure relief devices (PRD) and related hardware; determine necessary action.
6. Inspect condition and operation of cylinders / tank valves; determine necessary action.
7. Decommission cylinders according to recommended procedures. ■

SAMPLE QUESTIONS

COMPRESSED NATURAL GAS VEHICLE (TEST F1)

1. An EPA-certified CNG system has failed emissions due to a failure of a high cost system component. The best first step in repair should be to:
 - (A) replace the part and charge the customer to ensure timely service.
 - (B) attempt to locate a substitute component from a different manufacturer.
 - (C) modify the system to eliminate the part.
 - * (D) check with the system manufacturer for warranty.

2. Which of these should be used to check the fuel line connections after a compressed natural gas conversion?
 - (A) Nitrogen
 - (B) Propane
 - * (C) Non-ammonia soap
 - (D) Carbon dioxide

3. Technician A says that a CNG refueling receptacle must be located in the engine compartment. Technician B says that the refueling receptacle must have a different connection for each pressure-base system. Who is right?
 - (A) A only
 - * (B) B only
 - (C) Both A and B
 - (D) Neither A nor B

F1 SAMPLE QUESTIONS (CONTINUED)

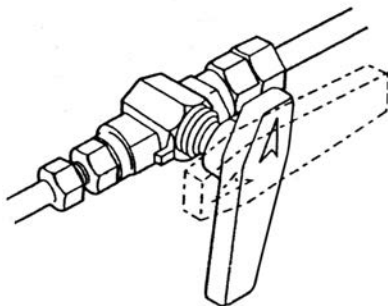

4. A vehicle with the valve shown is in for a routine coalescent filter change.
Technician A says that the valve should be closed to stop fuel flow to the engine.
Technician B says that the valve should be closed to stop fuel flow from the tank.
Who is right?
- (A) A only
* (B) B only
(C) Both A and B
(D) Neither A nor B

This question contains the word EXCEPT. Read the question carefully before choosing your answer.

5. A dedicated CNG vehicle has a no-start condition. All of these could be the cause EXCEPT:
- (A) no ignition source.
* (B) recurved timing.
(C) no fuel pressure.
(D) low battery voltage.

TEST SPECIFICATIONS AND TASK LIST

EXHAUST SYSTEMS (TEST X1)

Content Area	Questions in Test	Percentage of Test
A. Exhaust System Inspection and Repair	11	28%
1. Inspection (6)		
2. Repair (5)		
B. Emissions Systems Diagnosis	8	20%
C. Exhaust System Fabrication	6	15%
1. Pipe Bending (3)		
2. Welding and Cutting (3)		
D. Exhaust System Installation	8	20%
E. Exhaust System Repair Regulations	7	18%
Total	40	100%

A. Exhaust System Inspection and Repair (11 questions)

1. Inspection (6 questions)

1. Inspect all exhaust system components for noises, rattles, missing parts, configuration, routing and integrity by visual, audible, and thump testing; determine needed repair.
2. Inspect exhaust system for leaks, restrictions, and overheating by visual, audible, back pressure, vacuum, and temperature testing; determine needed repair.
3. Inspect exhaust subsystems [air injection reactor (AIR), exhaust gas recirculation (EGR), oxygen sensor(s) (O2S/HO2S), air/fuel ratio (AFR) sensor(s), turbochargers] and mounting hardware; determine needed repair.
4. Identify emission systems configuration using the emissions label; visually inspect exhaust system for evidence of tampering (missing/modified and/or improperly installed components); determine needed repair.
5. Inspect exhaust system electrical components; determine needed repair.
6. Inspect engine/transmission mount condition and alignment; determine needed repair.

2. Repair (5 questions)

1. Repair or replace failed or damaged mufflers, pipes, and related components.
2. Repair or replace damaged catalytic converters.
3. Repair or replace exhaust manifolds.
4. Repair or replace exhaust system mounting hardware and related installation components.

X1 TASK LIST (CONTINUED)

5. Repair or replace exhaust subsystems [air injection reactor (AIR), exhaust gas recirculation (EGR), oxygen sensor (O2S/HO2S), air/fuel ratio (AFR) sensor(s), turbochargers] and mounting hardware.

B. Emissions Systems Diagnosis (8 questions)

1. Identify failed catalytic converter(s); determine cause of failure; determine needed repair.
2. Identify failed air injection reactor (AIR) system; determine cause of failure; determine needed repair.
3. Identify failed exhaust gas recirculation (EGR) system; determine cause of failure; determine needed repair.
4. Identify failed air/fuel ratio (AFR) sensor(s) and oxygen sensor(s)(O2S/HO2S) component(s) and circuitry; determine cause of failure; determine needed repair.
5. Inspect emission systems for evidence of tampering (missing/modified and/or improperly installed component) based on the configuration identified on the emission label; determine needed repair.

C. Exhaust System Fabrication (6 questions)

1. Pipe Bending (3 questions)

1. Determine bending method (program card, pattern/copy, or custom).
2. Determine center of bends, rotation of pipe, depth of bends, and pipe diameter(s); perform bending operation.
3. Perform end-forming/flaring and hardware installation operations.
4. Determine the cause of pipe material failures that occur during bending operations.

2. Welding and Cutting (3 questions)

1. Select appropriate welding method (gas or MIG); perform welding operation; verify integrity of weld.
2. Set up and adjust welding equipment to repair application; observe applicable personnel, vehicle, and equipment safety procedures.
3. Select appropriate cutting method (gas or mechanical); perform cutting operation.
4. Set up and adjust cutting equipment to repair application; observe applicable personnel, vehicle, and equipment safety procedures.

D. Exhaust System Installation (8 questions)

1. Identify exhaust system configuration and options according to manufacturer's specifications (routing, single/dual, etc).
2. Select components according to accepted standards regarding material, type, design, and size.
3. Install appropriate exhaust system components (mufflers, resonators, catalytic converters, pipes, and manifolds).
4. Install appropriate exhaust system hardware (clamps, hangers, gaskets, flanges, fasteners, and heat shields).
5. Inspect system for proper exhaust component clearance and routing.
6. Inspect system for proper exhaust component-to-component connection sealing.
7. Install exhaust subsystem components [air injection reactor (AIR), exhaust gas recirculation (EGR) valve, oxygen sensor(s) (O2S/HO2S), air/fuel ratio (AFR) sensor(s)].

X1 TASK LIST (CONTINUED)

E. Exhaust System Repair Regulations (7 questions)

Note: Federal EPA law establishes minimum compliance requirements for emission systems repair. States and local municipalities may institute requirements that exceed the Federal EPA requirements. Knowledge of the Federal EPA requirements will be addressed in the following tasks.

1. Comply with warranty and diagnostic requirements regarding permissible catalytic converter installations.
2. Comply with requirements regarding prohibited catalytic converter installations.
3. Comply with requirements regarding record keeping.
4. Comply with requirements regarding catalytic converter replacement, location, and type.
5. Comply with requirements regarding replacement of air injection reactor (AIR), exhaust gas recirculations (EGR), oxygen sensor (O2S/HO2S), air/fuel ratio (AFR) sensor, and turbocharger systems.
6. Comply with requirements regarding exhaust system configuration. ■

SAMPLE QUESTIONS

EXHAUST SYSTEMS (TEST X1)

1. Which of these could cause an exhaust manifold gasket to fail?
 - (A) A failed AIR pump
 - * (B) A restricted exhaust system
 - (C) An inoperative converter
 - (D) A failed EGR valve

2. Which of these repairs should be made on a vehicle with a cracked catalytic converter flange?
 - * (A) Repair or replace the flange.
 - (B) Replace the converter.
 - (C) Replace the lead pipe.
 - (D) Seal and clamp the connection.

3. A visual inspection of a vehicle's catalytic converter reveals that the substrate (brick) has melted.
Technician A says that a failed oxygen sensor (O2S) could be the cause.
Technician B says that a misfiring spark plug could be the cause.
Who is right?
 - (A) A only
 - (B) B only
 - * (C) Both A and B
 - (D) Neither A nor B

4. To fit a 2 1/4" (57 mm) diameter pipe to fit over another 2 1/4" (57 mm) diameter pipe, a technician should expand the pipe to:
 - (A) 2 3/8" (60 mm) OD.
 - (B) 2 1/8" (54 mm) OD.
 - (C) 2 1/2" (64 mm) ID.
 - * (D) 2 1/4" (57 mm) ID.

X1 SAMPLE QUESTIONS (CONTINUED)

5. When performing a “converter-back” exhaust system installation, a technician should:
- (A) replace all hangers.
 - * (B) check for proper clearances.
 - (C) weld each connection.
 - (D) test for proper backpressure.
6. Technician A says that a broken transmission mount could cause the exhaust system to become misaligned. Technician B says that a broken engine mount could cause the exhaust system to become misaligned. Who is right?
- (A) A only
 - (B) B only
 - * (C) Both A and B
 - (D) Neither A nor B
7. Which of these is an illegal procedure to perform on a catalytic converter equipped vehicle?
- * (A) Install a test pipe in place of the converter.
 - (B) Install a muffler before the converter.
 - (C) Install a converter bolted directly to the exhaust manifold.
 - (D) Install a three-way converter in place of a two-way converter.
8. The flex pipe, located between the exhaust manifold and the catalytic converter, is broken. A flex pipe should be used as a replacement because it:
- (A) strengthens the exhaust systems.
 - (B) quiets the exhaust system.
 - (C) helps to heat the converter.
 - * (D) allows for engine movement.

TEST PREP & TRAINING

Taking an ASE certification test doesn't have to be a high stress challenge. The ASE website contains test preparation and training information tailored to your specific needs. Visit www.ase.com and use the "Test Prep & Training" tab. We've loaded this section of our website with plenty of information to help boost both your knowledge and your confidence—two of your most important tools as a test-taker.

Official ASE Practice Tests

The easy way to try your hand at taking ASE-style certification exams, without the stress and high stakes of the real thing.

Test Taking Tips

An easy, self-guided introduction to taking your ASE certification test, including examples of the types of questions you'll see and proven tips for success.

Study Guides

Free, step-by-step guides to help you understand what's involved in each test—including sample questions and suggestions for further preparation.

CBT Test-Drive

Not familiar with ASE's computer-based tests? This self-paced presentation will show you how they work, so you'll feel right at home with the testing format.

In-service Training Providers

You can choose from a variety of training programs, both instructor-led and self-directed, that have been evaluated through a quality-assurance process called CASE (Continuing Automotive Service Education) and accredited by ASE.

Community Colleges and Technical Training Schools

Get instructor-led, hands-on training at schools accredited by the National Automotive Technicians Education Foundation.

ATMC for more training options

The Automotive Training Manger Council is a professional organization of individuals responsible for the development and delivery of training in the auto and truck industries and a member of the ASE Industry Education Alliance. The ATMC administers the Continuing Automotive Service Education (CASE) program for the ASE accreditation of training providers serving the transportation industry. A list of CASE accredited training providers can be found at the ATMC website. www.atmc.org

Other test prep and training programs

Many test-takers have used aftermarket test prep and training programs and found them helpful. Please note that ASE has neither reviewed nor approved the content of these programs and providers.



COPYRIGHT © 2017 by
National Institute for
AUTOMOTIVE SERVICE EXCELLENCE
All rights reserved



National Institute for
AUTOMOTIVE SERVICE EXCELLENCE
101 Blue Seal Dr., S.E., Suite 101
Leesburg, VA 20175

To contact us:

703-669-6600

www.ase.com