



SVS-05-13
5/8/2013

TO: ALL ISUZU POWERTRAIN DISTRIBUTORS & DEALERS: SERVICE, WARRANTY & PARTS PERSONNEL

SUBJECT: ALL 4L-SERIES ENGINES ELIMINATION OF OIL PUMP O-RING

Isuzu Motors America, LLC PowerTrain Division (ISZAPT) has eliminated the oil pump O-ring gasket on all 4L-series engines due to parts communization (includes Tier 4 replacement engines). This is the O-ring fitted between the oil pump and oil pump body. Please refer to the pages below for details. This parts change will be implemented in production engines in June 2013.

Parts Elimination Information

Interchange Ability	Affected Parts	Current Parts	Q'ty	New Parts	Q'ty
	GASKET;OIL PUMP	897109 6790	1	(Elimination)	-

Best Regards,

Mike Ruiz

Service Specialist

<Reference Drawing>

Case2:OIL PUMP is attached to FRONT PLATE

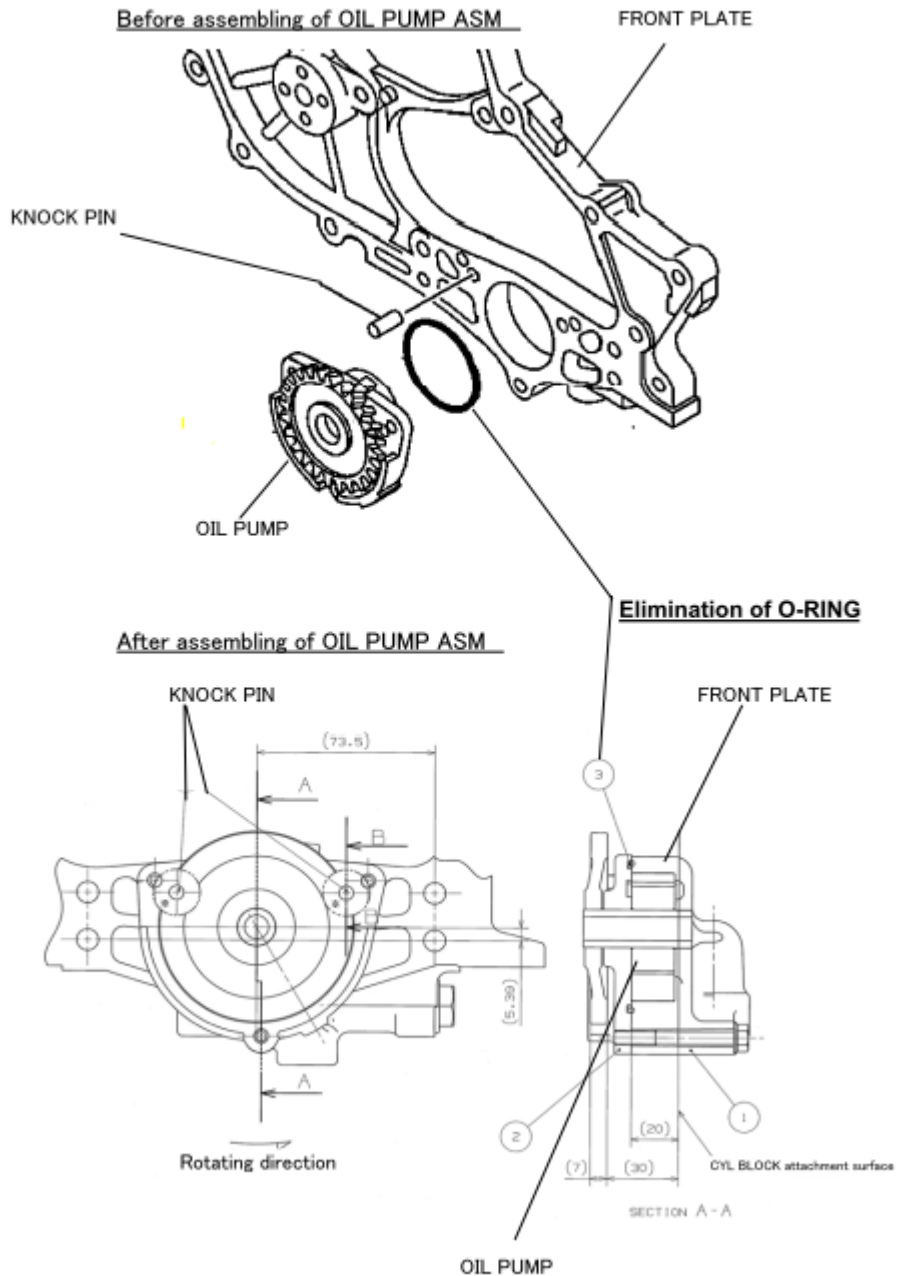

<Reference Drawing>

Case 1: OIL PUMP is attached to PUMP BODY

Before assembling of OIL PUMP ASM

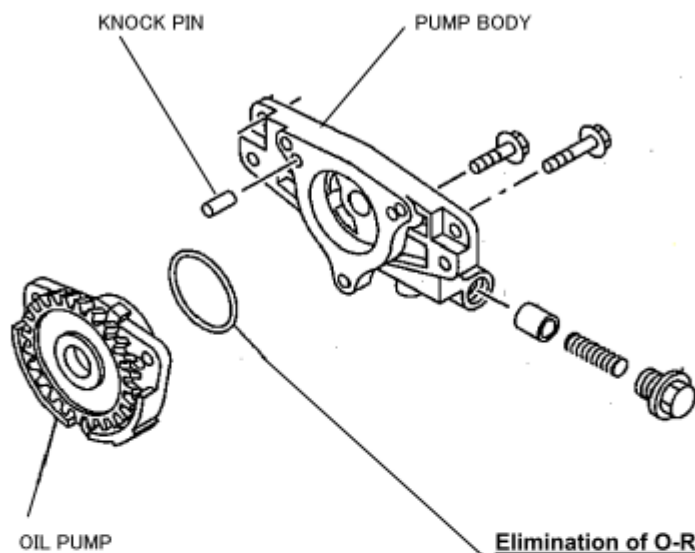

After assembling of OIL PUMP ASM

